

Since 1988, Enodis has been designing and manufacturing innovative equipment and appliances for professional kitchens.

Our mission is to bring added value to professionals. Enodis is now a fully French, family-owned SME, an innovative, modern company that offers design, manufacturing and distribution.



Enodis, a member of Excellence Française



Excellence Française - French Excellence - is a system set up in 2009 designed to recognise creativity and innovation in the most dynamic areas of business and industry across France, and the men and women whose talent and devotion have contributed the most to France's global influence.

Enodis was inducted into the French Excellence hall of fame in 2020 along with Renault, Laboratoire Mérieux and Fondation De Gaulle.



A French family-run company

Enodis

Enodis has revolutionised professional kitchens. We have been developing innovative products for over 35 years:

1. Our high-performance fryers that can cook over 50 kg of fries in less than 15 L of oil.
2. Our double-sided grills used in MacDonald's restaurants around the world.
3. Our convection and steam combi ovens.
4. Induction appliances providing cooking comfort and convenience.
5. Our Merrychef ultra high-speed ovens: 4 croque-monsieurs in 60 seconds, 5 panini in 40 seconds...
6. Our bespoke single-unit ovens for guaranteed health and safety.
7. Our fully customisable self-service units



Made in France

Our factory in Auxerre in the Yonne region of France is where we make our bespoke ovens - French expertise that is used around the world. Expertise that our metal workers and welders pass from one generation to the next. We combine tradition and innovation to provide sustainable, high-performance solutions for professionals in the restaurant and catering industry.

2018

Factory opening in Monéteau, France

Quality and reliability

Our success here at Enodis is due to several factors:



It's a family frame of mind

Enodis was founded by François Houpert, who manages the company alongside his two sons Alexandre and Philippe.

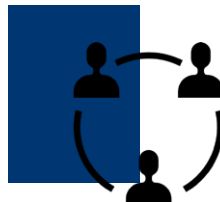

Our skilled and dependable teams

Enodis as a company is known for its dependable staff, who stay with us for more than 15 years on average.



Our adaptable and innovative solutions

We can create kitchens from A to Z, from scratch to finishing touches for all types of restaurants and catering establishments, working closely with our fitters and our specialist design studios.

Performance & Power

Enodis

Standard AC D 40-004

Regarding self-service, display and restaurant equipment. Standardising design and construction rules to ensure hygienic use.

Chilled cabinets with a maximum ambient temperature of 25°C must keep the core temperature of the food on display lower than 8°C during service; food products must come straight from a cold room and be placed in a temperature of 0 to 3°C.

The maximum core temperature of heated units is 63°C during service and food products must come straight from a heated area and be placed in a core temperature of 72 to 80°C.



Running on gas with GWP < 150 - A Nearly Zero Energy Building (NZEB)

Enodis is AFNOR-compliant.

Suitable for cleaning in accordance with AFNOR directives, the French industrial standards authority (Association Française de Normalisation).

Temperature performance in accordance with AFNOR directives.

Complies with catering and restaurant directives.

Maximum food safety.

Examples of laboratory temperature tests

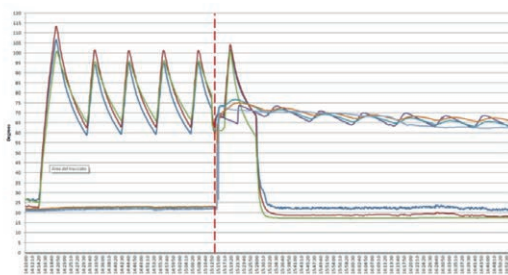

The evolution of refrigerants

F-gas regulation: ban on the placing on the market of appliances using refrigerants with a GWP above the following thresholds:

1 January 2020 ≥ 2500

1 January 2023 ≥ 150



Enodis & R455A

Preparing for changes to F-gas regulations and protecting our environment:

R455A has no environmental impact and is the preferred choice for customers concerned about the planet.

So that we can produce cooling technology in a sustainable way, we keep three important elements in mind: cost, reliability and the environment. That is why we have opted for a refrigerant that offers the best balance between performance and safety.

R455A is classed as low flammability, allowing you a greater usable maximum load.

The evolution of insulating reagents

F-gas regulation:

A ban was introduced on 1 January 2020 on the placing on the market of appliances containing HFCs with a Global Warming Potential higher than 150.

Traditional reagents: R134a (1,300 GWP), R245a (950 GWP)

New generation: HCFO GWP = 1



Choosing R455A

Preparing for changes to F-gas regulations and protecting our environment:

Hydrochlorofluoroolefin (HCFO) is free from CFC/HCFC and has the lowest Global Warming Potential (= 1); it is the best choice for the planet.

Improved thermal resistance: HCFO insulation is 4% greater than the foam obtained from R134a or R245a; it has a density of 42 kg/m³ compared with traditional reagents, which have a density of 38 to 40 kg/m³.

Insulation quality: HCFO has a more powerful chemical reaction than traditional reagents as the foam is able to penetrate all panel interstices without leaving any bubbles. The heating of the moulds during the injection further increases the reaction efficiency as well as the homogeneity of the insulation obtained.

Performance stability: HCFO insulation remains stable throughout its lifetime, unlike foams obtained with traditional reagents that lose an average of 5% thermal efficiency per year.

01
**TABLES
& TROLLEYS**..... 8

02
**SELF-SERVICE
SPECIFICATIONS**
18.....

03
**ADULT
SELF-SERVICE UNITS**.....26

04
**CHILD
SELF-SERVICE UNITS**
118.....

05
**BESPOKE
SELF-SERVICE UNITS**.....186

06
BUILT-IN.....194

07
SELF-SERVICE
TAKEAWAY
224.....

08
HOTEL
BUFFETS.....252

09
COLOUR CHART
258.....

LAMINAR FLOW TABLES & TROLLEYS



Enodis TABLES & TROLLEYS

Cool'Station: ambient temperature 25°C

Energy saving:

GN1/3 containers are kept cold by the laminar flow air flow.

Versatile and hygienic:

Removable GN1/1 trays in white polythene thickness 20 mm, can be replaced with GN1/1 containers.

Economic, flexible and mobile:

Preparing cold food at ambient temperature.
No need for a chilled room.

Hygiene:

Bactericidal UVC lamp.

Hygiene and maintenance:

Ventilated evaporator with actuators for upkeep and cleaning.

Hot'Station: ambient temperature 25°C

Energy saving:

GN1/3 containers are kept warm by the laminar flow air flow.

Versatile and hygienic:

Removable GN1/1 trays in white polythene thickness 20 mm, can be replaced with GN1/1 containers.

Hygiene and maintenance:

Ventilated heating unit with actuators for upkeep and cleaning.

Enodis
COOL'STATION
& HOT'STATION

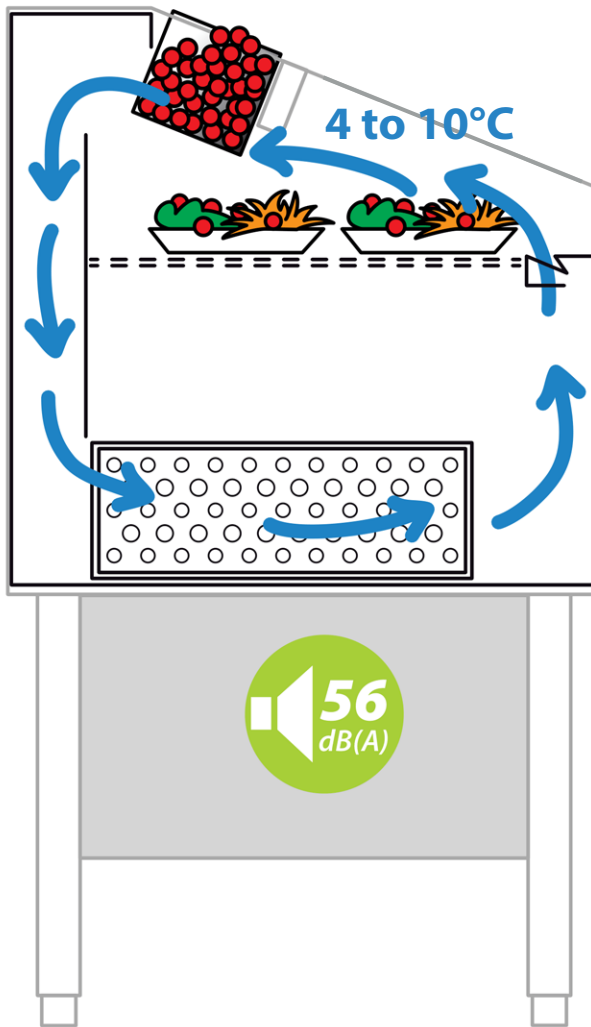

Air distribution
How the Cool'Station works

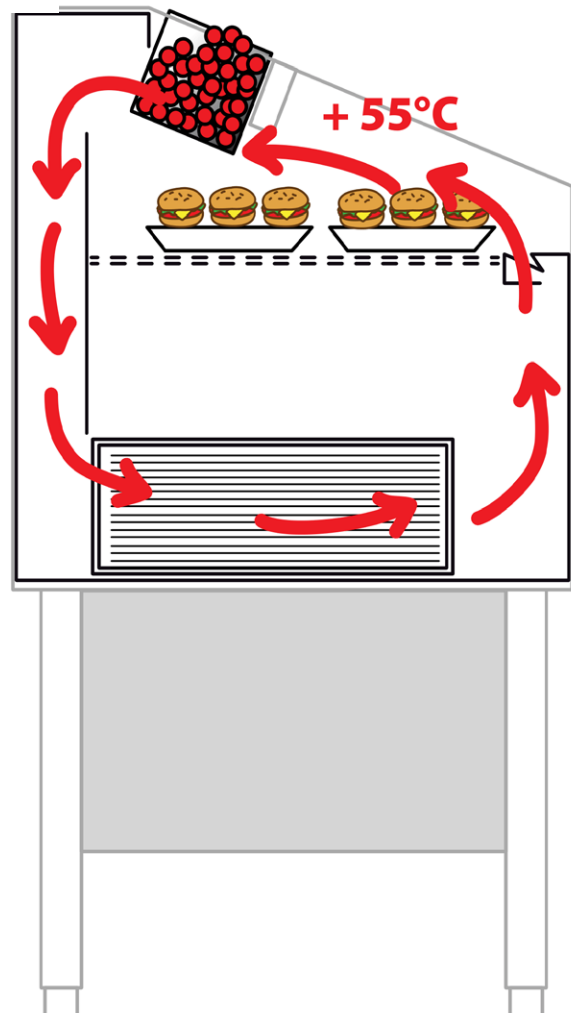

Air distribution
How the Hot'Station works

Our most

Enodis
COOL'STATION
& HOT'STATION

POPULAR PRODUCTS

Hygienic

Ventilated evaporator with actuators for upkeep and cleaning
Bactericidal UVC lamp



Versatile

Removable GN1/1 trays in white polythene, can be replaced with various add-ons including GN1/1 containers



Ergonomic

Preparing cold food at 25°C ambient temperature (like in a cold room). No need for a chilled room

COOL'STATION

Enodis COOL'STATION & HOT'STATION

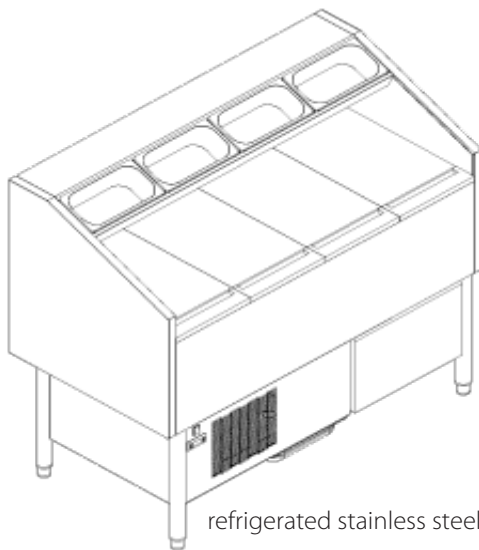

refrigerated stainless steel tank

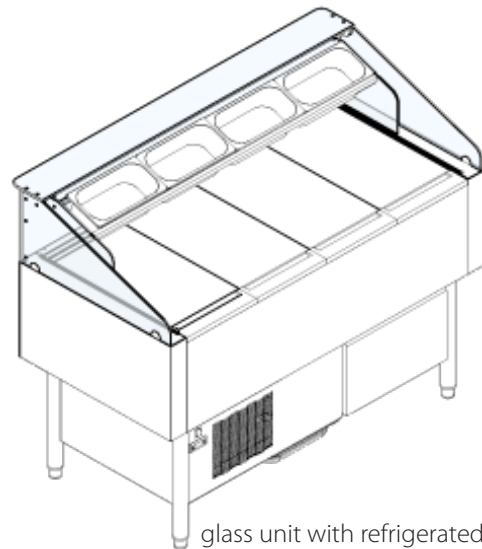

glass unit with refrigerated tank

DESCRIPTION

AISI 304 stainless steel structure. Refrigerated containers and work surface with ventilated air flow (4°C to 10°C in ambient temperature of 25°C). White* food-grade polythene GN1/1 work surface trays thickness 20 mm can be replaced with GN1/1 containers, depth 100 mm. *Black available as add-on. Refrigerated superstructure for GN1/3 trays (trays available as add-on). Oscillating ventilated evaporator with bactericidal UVC lamp. Condensate drip tray included. Single-phase hermetic refrigeration (R455A). CFC-free guarantee. Refrigerated storage tank with 3 GN1/1 grids. (TCS14R + TCS145EVR) or 2 x GN1/1 (TCS18R + TCS18EVR). Fixed models available without refrigeration unit (as add-on).

Glazed Cool'Station: glazed superstructure with glass holder for GN1/3 trays (trays available as add-on). Pull-out for easy cleaning plus standard LED lighting.

Cool'Station in stainless steel

Item no.	Specifications	Dimensions W x D x H mm	Price in € (plus VAT)	LED lighting add-on*
TCS12	Cool'Station 3 GN1/1 without refrigerated storage	1,045 x 700 x 1,205	8,093	305
TCS14	Cool'Station 4 GN1/1 without refrigerated storage	1,370 x 700 x 1,205	9,106	345
TCS18	Cool'Station 5 GN1/1 without refrigerated storage	1,695 x 700 x 1,205	10,683	377
TCS14R	Cool'Station 4 GN1/1 with refrigerated storage 1 door GN1/1	1,370 x 700 x 1,205	13,347	345
TCS18R	Cool'Station 5 GN1/1 with refrigerated storage 2 door GN1/1	1,695 x 700 x 1,205	15,365	377

*Add ELED to item number for 24V LED add-on

Glazed Cool'Station

Item no.	Specifications	Dimensions W x D x H mm	Price in € (plus VAT)
TCS12EV	Cool'Station 3 GN1/1 glazed version without refrigerated storage	1,125 x 700 x 1,205	11,310
TCS145EV	Cool'Station 4 GN1/1 glazed version without refrigerated storage	1,450 x 700 x 1,205	12,421
TCS18EV	Cool'Station 5 GN1/1 glazed version without refrigerated storage	1,775 x 700 x 1,205	13,695
TCS145EVR	Cool'Station 4 GN1/1 with refrigerated storage 1 door GN1/1	1,450 x 700 x 1,205	17,208
TCS18EVR	Cool'Station 5 GN1/1 with refrigerated storage 2 door GN1/1	1,775 x 700 x 1,205	19,467

HOT'STATION

Enodis COOL'STATION & HOT'STATION

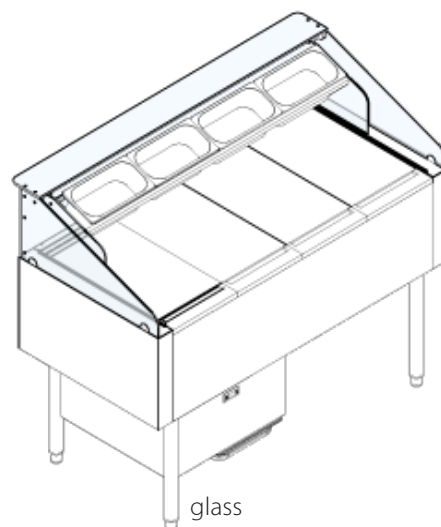
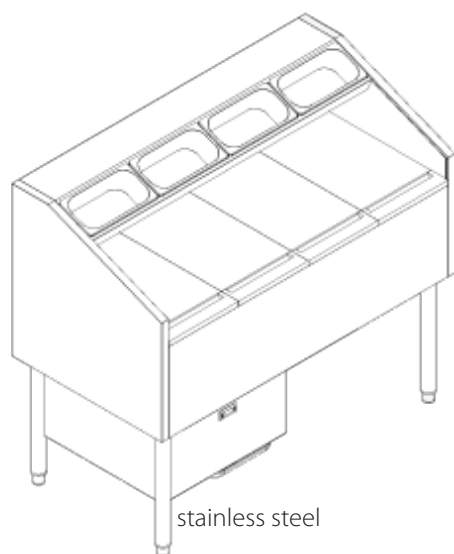

DESCRIPTION

AISI 304 stainless steel structure. Heated containers and work surface with ventilated air flow. White food-grade polythene GN1/1 work surface trays thickness 20 mm can be replaced with GN1/1 containers, depth 100 mm. Heated superstructure for GN1/3 trays (trays available as add-on).

Hot'Station in stainless steel

Item no.	Specifications	Power	Dimensions W x D x H mm	Price in € (plus VAT)	LED lighting add-on*
THS12	Hot'Station 3 GN1/1	1,600	1,045 x 700 x 1,205	8,663	305
THS14	Hot'Station 4 GN1/1	2,260	1,370 x 700 x 1,205	10,039	345
THS18	Hot'Station 5 GN1/1	2,560	1,695 x 700 x 1,205	11,778	377

*Add ELED to item number for 24V LED add-on

Glazed Hot'Station

Item no.	Specifications	Power	Dimensions W x D x H mm	Price in € (plus VAT)
THS12EV	Hot'Station 3 GN1/1 glazed version	1,600	1,125 x 700 x 1,205	12,105
THS145EV	Hot'Station 4 GN1/1 glazed version	2,260	1,450 x 700 x 1,205	13,298
THS18EV	Hot'Station 5 GN1/1 glazed version	2,560	1,775 x 700 x 1,205	14,660

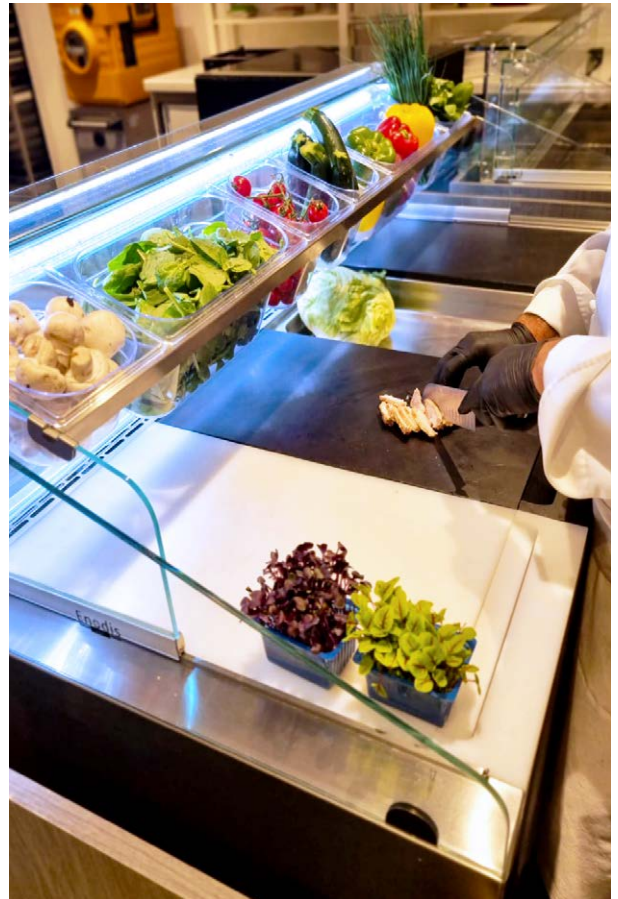

OPTIONS

Enodis
COOL'STATION & HOT'STATION

COOL'STATION & HOT'STATION

COOL'STATION ADD-ONS		
Item no.	Name	Price in € (plus VAT)
BA11100	GN1/1 tray depth 100 mm - stainless steel	46
BP11100	GN1/1 tray depth 100 mm - transparent polycarbonate	51
BA13150	GN1/3 tray depth 150 mm - stainless steel	44
BP13150	GN1/3 tray depth 150 mm - transparent polycarbonate	21
RPP412ICS	Set of 4 stainless steel wheels 125 mm (2 with brakes)	318
SUP-BOB	Coil support	290
MVSGTCS14	Deduction for Cool'Station 4 GN on open cupboard without refrigeration unit	-533
MVSGTCS14R	Deduction for Cool'Station 4 GN with storage without refrigeration unit	-963
MVSGTCS18	Deduction for Cool'Station 5 GN on open cupboard without refrigeration unit	-574
MVSGTCS18R	Deduction for Cool'Station 5 GN with storage without refrigeration unit	-1,025
BLACK	Black polythene panel to replace white panels (additional charge for each piece)	228
PVSTRATTCS12	Additional charge for Cool'Station 3 GN (stainless steel or glazed) with laminate trim on 3 sides	1,639
PVSTRATTCS14	Additional charge for Cool'Station 4 GN (stainless steel or glazed) with laminate trim on 3 sides	1,738
PVSTRATTCS18	Additional charge for Cool'Station 5 GN (stainless steel or glazed) with laminate trim on 3 sides	1,875

HOT'STATION ADD-ONS		
Item no.	Name	Price in € (plus VAT)
BA11100	GN1/1 tray depth 100 mm - stainless steel	46
BP11100	GN1/1 tray depth 100 mm - transparent polycarbonate	51
BA13150	GN1/3 tray depth 150 mm - stainless steel	44
BP13150	GN1/3 tray depth 150 mm - transparent polycarbonate	21
RPP412ICS	Set of 4 stainless steel wheels 125 mm (2 with brakes)	318
SUP-BOB	Coil support	290
BLACK	Black polythene panel to replace white panels (additional charge for each piece)	207
PVSTRATTCS12	Additional charge for Hot'Station 3 GN (stainless steel or glazed) with laminate trim on 3 sides	1,639
PVSTRATTCS14	Additional charge for Hot'Station 4 GN (stainless steel or glazed) with laminate trim on 3 sides	1,738
PVSTRATTCS18	Additional charge for Hot'Station 5 GN (stainless steel or glazed) with laminate trim on 3 sides	1,875



HOLDING TROLLEYS

Enodis
TABLES & TROLLEYS



DESCRIPTION

- Adaptable to all requirements with a wide range of models to fit 1/1 or 2/1 Gastronorm trays.
- Adjustable air outlets (on static version).
- Frame and parts in 304 stainless steel on 4 height-adjustable feet (± 10 mm).
- Cavity insulated with 40 mm rock wool.
- CEE 7/7 socket with spiral cable for maximum 1,200 W.
- Temperature range 30°C to 85°C. Guaranteed to preserve food at optimal temperature.
- Magnetic door sensor with door alarm (ventilated model).
- Ventilated humidifier models with trolley included: 5 levels of water injection (from tank stored under the trolley). Tank capacity 2 L. Designed to keep products humidified throughout the work cycle.

Ventilated temperature-holding cabinets

Item no.	Description	Tray capacity h 40 mm	Optional trolley	Power supply	Total power	Dimensions WxDxH (mm)	Price in € (plus VAT)
XM10U1PC	Mobile temperature-holding trolley with 10 trays, humidity control, door and air vents, includes trolley bumper	10 x GN 1/1	included	230V 1N 50Hz	1,200 W	460 x 735 x 930	6,915
XM10U2PC	Mobile temperature-holding trolley with 10 trays, humidity control, door and air vents, includes trolley bumper	10 x GN 2/1 or 20 x GN 1/1	included	230V 1N 50Hz	1,200 W	665 x 855 x 930	8,183
XM10V1PA	Leg-mounted ventilated temperature-holding cabinet with 10 trays, door and air vents	10 x GN 1/1	add-on	230V 1N 50Hz	1,200 W	415 x 690 x 730	4,659
XM10V2PA	Leg-mounted ventilated temperature-holding cabinet with 10 trays, door and air vents	10 x GN 2/1 or 20 x GN 1/1	add-on	230V 1N 50Hz	1,200 W	620 x 810 x 730	5,618
XM24U1PC	Mobile temperature-holding trolley with 24 trays, humidity control, door and air vents, includes trolley bumper	24 x GN 1/1	included	230V 1N 50Hz	1,200 W	460 x 735 x 1,700	8,880
XM24V1PC	Ventilated mobile temperature-holding trolley with 24 trays, door and air vents, includes trolley bumper	24 x GN 1/1	included	230V 1N 50Hz	1,200 W	460 x 735 x 1,700	7,553
XCMR01SV	Trolley for temperature-holding cabinet	GN1/1	-	-	-	-	1,014
XCMR02SV	Trolley for temperature-holding cabinet	GN2/1	-	-	-	-	1,315



SELF



CHOOSING THE RIGHT SELF-SERVICE UNIT IN 3 STEPS

Enodis
SELF

01

CHOOSE YOUR SIZE: ADULT OR CHILD

Self-service units are available in 2 different sizes: ADULT and CHILD.

The adult unit rail is placed at a height of 800 mm and the child self-service unit at 650 mm.

The adult unit has a height of 900 mm. The child unit has a height of 750 mm.

We always leave 900 mm to enable staff to work at an ergonomic height (excluding bain maries and glass-ceramic units).

ADULT SELF-SERVICE UNITS

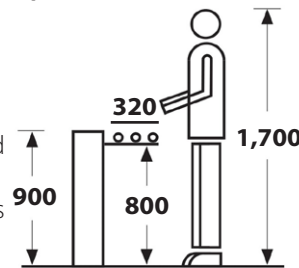

CHILD SELF-SERVICE UNITS

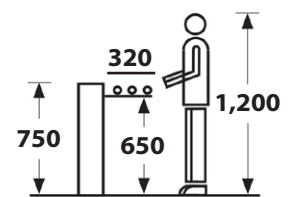

REFRIGERATED STORAGE

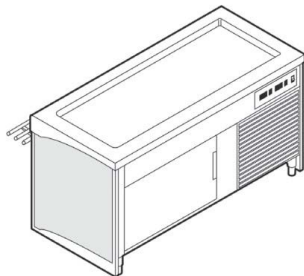

Closed refrigerated lower unit with cupboard doors on service side. For use with refrigerated self-service units.

OPEN CUPBOARD

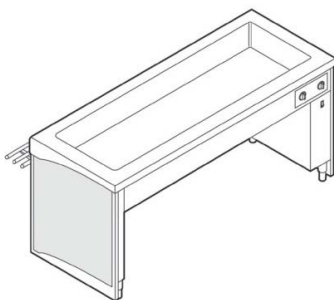

Empty space under unit open on service side, no bottom to allow trays/trolleys to slide in/out. The open cupboard is available with all self-service units.

02

CHOOSE YOUR TYPE WITH STORAGE, OPEN CUPBOARD

OR HEATED CHAMBER

HEATED CHAMBER

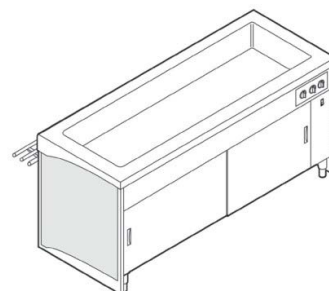

Closed heated and ventilated lower unit with sliding doors on service side. The heated chamber keeps the temperature between 0 and 85°C (available as add-on) and includes a shelf. For use with heated units.

CHOOSING THE RIGHT SELF-SERVICE UNIT IN 3 STEPS

Enodis
SELF

03 CHOOSE YOUR STORAGE CAPACITY

The storage capacity will depend on the number of guests, the number of courses and services, and the size of the room.

Example:

An adult self-service unit catering for 200 covers with two restockable cold display cabinets.

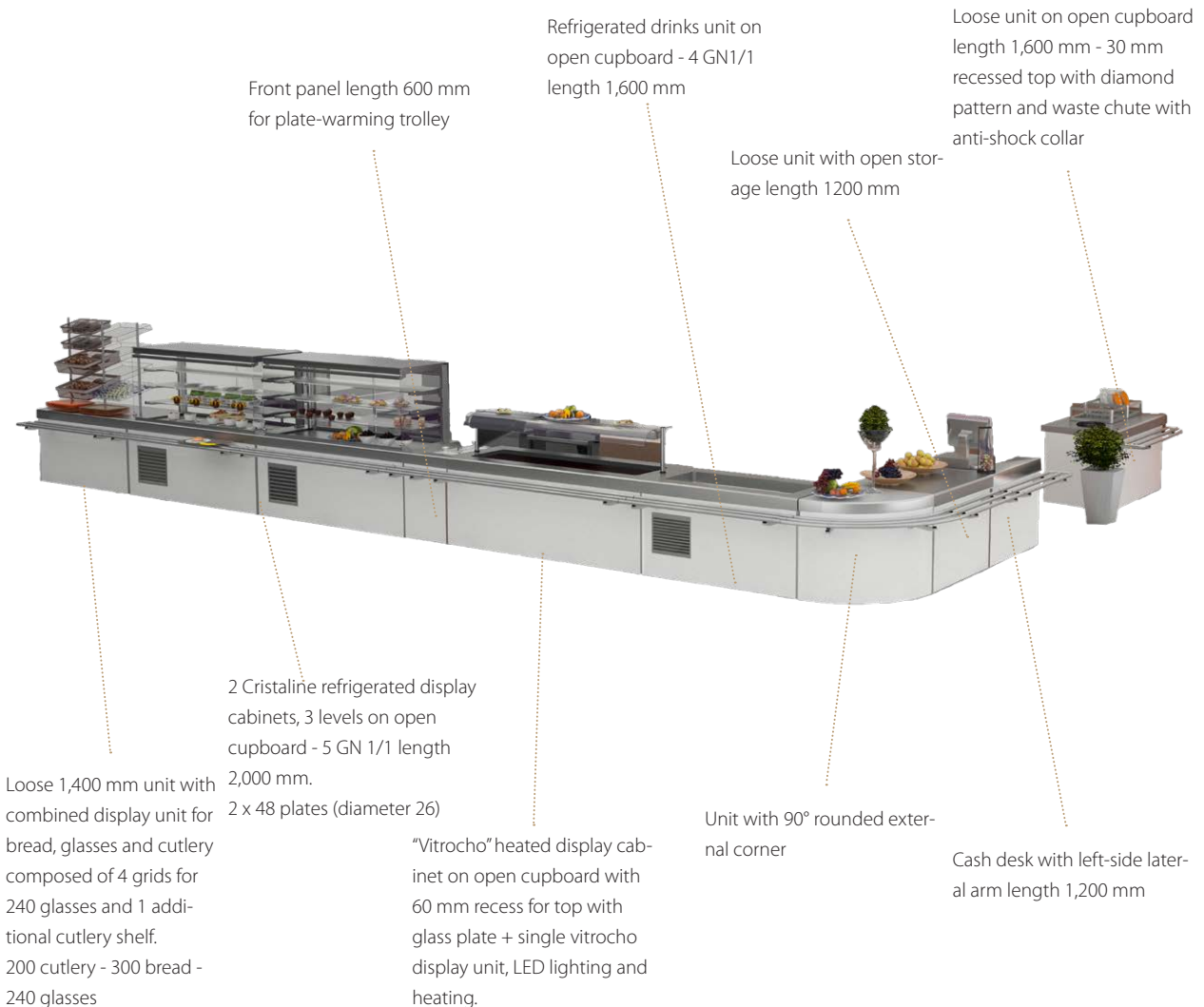



Our most ^{Enodis} POPULAR PRODUCTS ^{SELF}

Hygienic

Radiant tank
Radiant heat chamber
Tops assembled with clean edges



High performance

Ventilated cooling with removable tank bottom
Refrigeration system noise level 56 dB(A). Comes with removable bottom. Uses refrigerant R455A (GWP: 146)
LED lighting
Touch control with smart clock (available as add-on)

Design

Laminate façade with 15 mm elevation (as standard)
250 colours available
Stainless steel corner guards
Tempered glass rail thickness 10 mm + LED lighting (available as add-on)







ADULT SELF-SERVICE UNITS





ADULT
SELF-SERVICE
UNITS

ALL ADULT SELF-SERVICE UNITS

Enodis
ADULT



01

UTENSIL

DISPENSERS

30

02

COLD

UNITS

38

03

HEATED

UNITS

70



04

**AUXILIARY
UNITS**

96

112

05

ORGANISERS

01

UTENSIL DISPENSERS



Our most

Enodis
ADULT
Easy'
Serve

POPULAR PRODUCTS

Tray holders

All AISI 304 stainless steel structure. Lower tray display units with 4 closed sides. Adjustable stainless steel legs on actuators.

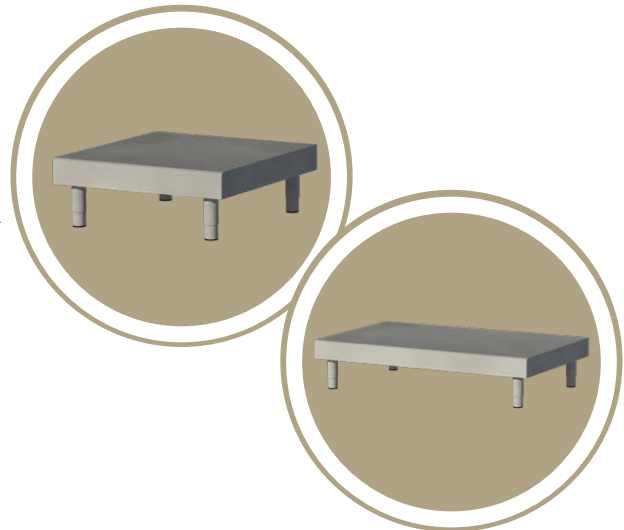

Cutlery racks

All AISI 304 stainless steel structure. Polished stainless frame with 40 mm bars to hold GN1/3 polycarbonate cutlery trays. Capacity: 100 sets of cutlery in 3 GN1/3 trays. BPA-free copolyester trays provided.

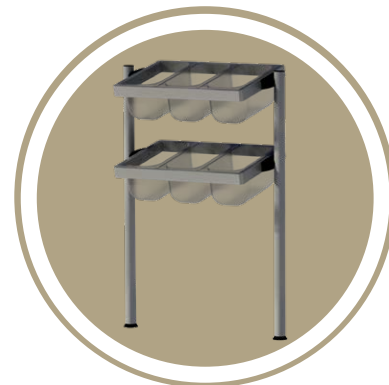

Bread trays

All AISI 304 stainless steel structure. Polished stainless frame with 40 mm bars to hold GN2/1 polycarbonate bread trays. Capacity: 150 bread rolls in 1 GN2/1 tray. BPA-free copolyester trays provided.



Our most

Endis
ADULT
Easy'
Serve

POPULAR PRODUCTS

Glass racks

All AISI 304 stainless steel structure. Stainless steel frame with 40 mm bars. Version with stainless steel slide-out grill for storing and displaying glasses. Maximum glass dimensions: Diameter 80 x H92 mm. Capacity: 60 glasses/diameter 75 or 54 glasses/diameter 80.

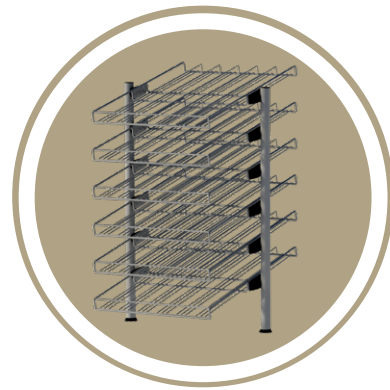

Tray/holder racks

All AISI 304 stainless steel structure. Stainless steel frame with 40 mm bars. Rack system for quick restocking by simply swapping trays or holders.

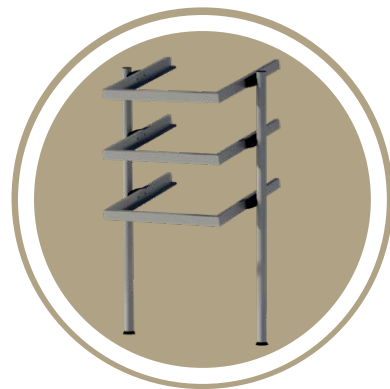

TRAY HOLDERS, BREAD & CUTLERY DISPLAY COUNTERS

Enodis
ADULT

Easy'
Serve

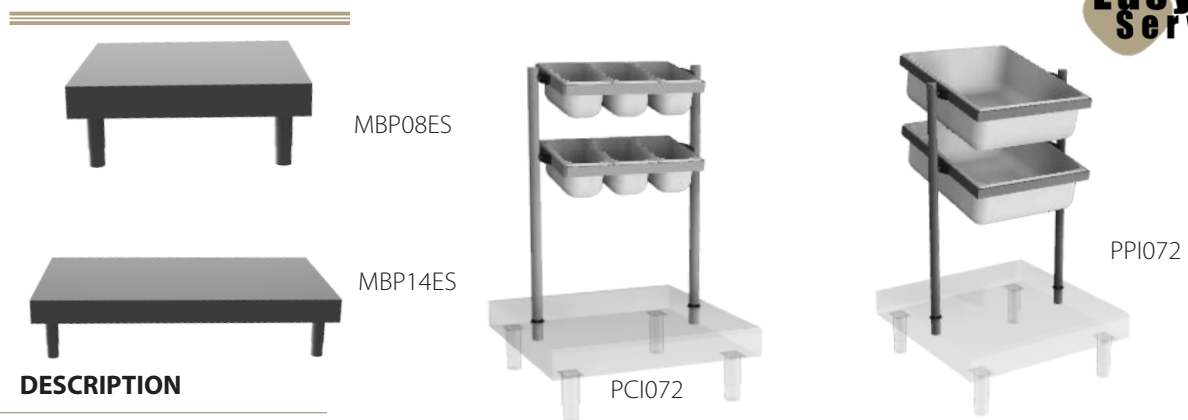

DESCRIPTION

Tray holders:

All AISI 304 stainless steel structure. Lower units with 4 closed sides for displaying trays or other items.

Tray holders

Item no.	Tray capacity	Length	Stainless steel top - Price in € (plus VAT)
MPB08ES	2 x 135 trays of 370 x 430	800	2,062
MPB14ES	4 x 135 trays of 370 x 430	1,400	3,036

* Please add G to the item number when ordering granite top units (category 1).

DESCRIPTION

Cutlery rack:

All AISI 304 stainless steel structure. Polished stainless frame with 40 mm bars to hold GN1/3 polycarbonate cutlery trays. Capacity: 100 sets of cutlery in 3 GN1/3 trays. BPA-free copolyester trays provided.

Cutlery racks

Item no.	Tray capacity	Cutlery capacity	Length	Price in € (plus VAT)
PCI071	1 level with 3 x GN1/3 trays	100	750	317
PCI072	2 levels with 3 x GN1/3 trays	200	750	635
PCI141	1 level with 6 x GN1/3 trays	200	1,400	635
PCI142	2 levels with 6 x GN1/3 trays	400	1,400	1,265

DESCRIPTION

Bread trays:

All AISI 304 stainless steel structure. Polished stainless frame with 40 mm bars to hold GN2/1 polycarbonate bread trays. Capacity: 150 bread rolls in 1 GN2/1 tray. BPA-free copolyester trays provided.

Bread trays

Item no.	Tray capacity	Bread roll capacity	Length	Price in € (plus VAT)
PPI071	1 level with 1 x GN2/1 tray	150	750	401
PPI072	2 levels with 1 x GN2/1 tray	300	750	797
PPI141	1 level with 2 x GN2/1 trays	300	1,400	797
PPI142	2 levels with 2 x GN2/1 trays	600	1,400	1,591

BREAD & TRAY DISPLAY COUNTERS, COMBINED BREAD, CUTLERY & GLASS DISPLAY COUNTERS

Enodis
ADULT

Easy'
Serve

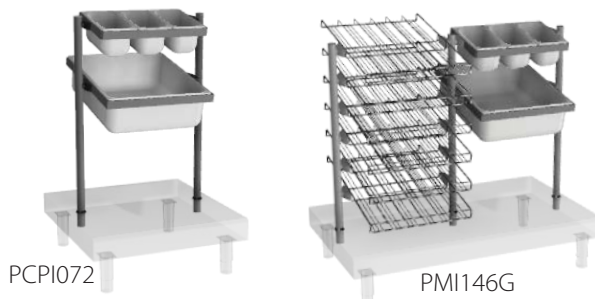

PCPI072

PMI146G

DESCRIPTION

All AISI 304 stainless steel structure. Polished stainless frame with 40 mm diameter bars to hold GN1/3 polycarbonate cutlery trays. Capacity: 100 sets of cutlery in 3 GN1/3 trays. BPA-free copolyester trays provided.

Bread and cutlery display units

Item no.	Composition	Cutlery capacity	Bread roll capacity	Length	Price in € (plus VAT)
PCPI072	3 x GN1/3 trays - 100 for cutlery 1 x GN2/1 tray - 200 for bread	100	150	750	714
PCPI142	2 sets of 3 GN1/3 trays - 100 for cutlery 2 x 1 GN2/1 tray - 200 for bread	200	300	1,400	1,427

DESCRIPTION

Combined bread, cutlery & glass display units:

All AISI 304 stainless steel structure. Version with stainless steel grid for storing and displaying glasses plus 1 bread tray and 3 cutlery trays. Capacity: 3 cutlery trays (approx. 100 sets of cutlery).

One bread tray: capacity approx. 150 small bread rolls. BPA-free copolyester trays provided.

Maximum glass dimensions: diameter 80 x H92 mm. Capacity: 60 glasses/diameter 75 or 54 glasses/diameter 80.

Combined bread, cutlery & glass display units

Item no.	Cutlery capacity	Bread roll capacity	Glass capacity	Length	Price in € (plus VAT)
PMI71G	100	150	1 grid - 60 glasses	750	1,019
PMI72G	100	150	2 grids - 120 glasses	750	1,322
PMI142G	100	150	2 grids - 120 glasses	1,400	1,322
PMI143G	100	150	3 grids - 180 glasses	1,400	1,623
PMI144G	100	150	4 grids - 240 glasses	1,400	1,925
PMI145G	100	150	5 grids - 300 glasses	1,400	2,228
PMI146G	100	150	6 grids - 360 glasses	1,400	2,530

GLASS AND TRAY RACKS

Enodis
ADULT

Easy'
Serve

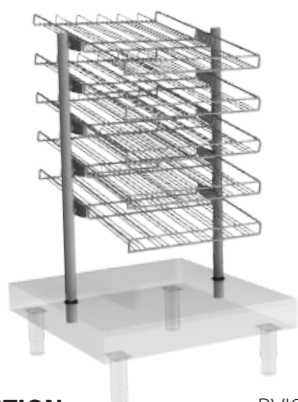

PVI075G



PVI144C

DESCRIPTION

Glass racks

All AISI 304 stainless steel structure. Version with stainless steel slide-out grid for storing and displaying glasses. Maximum glass dimensions: diameter 80 x H92 mm. Capacity: 60 glasses/diameter 75 or 54 glasses/diameter 80.

Glass racks

Item no.	Slide-out glass grids	Glass capacity	Length	Price in € (plus VAT)
PVI073G	3 levels	180	750	952
PVI074G	4 levels	240	750	1,269
PVI075G	5 levels	300	750	1,515
PVI076G	6 levels	360	750	1,766
PVI077G	7 levels	420	750	2,001
PVI078G	8 levels	480	750	2,197
PVI141G	2 x 1 level	120	1,400	608
PVI142G	2 x 2 levels	240	1,400	910
PVI143G	2 x 3 levels	360	1,400	1,212
PVI144G	2 x 4 levels	480	1,400	1,515
PVI145G	2 x 5 levels	600	1,400	1,818
PVI146G	2 x 6 levels	720	1,400	2,119

DESCRIPTION

Tray/holder racks:

All AISI 304 stainless steel structure. Rack system for quick restocking by simply swapping trays or holders.

Tray/holder racks

Item no.	Levels	Tray capacity	Length	Stainless steel top - Price in € (plus VAT)
PVI73C	3 levels	3	750	1,224
PVI74C	4 levels	4	750	1,632
PVI75C	5 levels	5	750	1,949
PVI143C	2 x 3 levels	6	1,400	2,446
PVI144C	2 x 4 levels	8	1,400	2,945
PVI145C	2 x 5 levels	10	1,400	3,441

SELF-SERVICE AND DISPLAY - ADD-ONS

Enodis
ADULT

**Easy'
Serve**

SELF-SERVICE AND DISPLAY ADD-ONS		
Item no.	Name	Price in € (plus VAT)
RPP412I	Set of 4 stainless steel wheels diameter 125 mm (2 with brakes)	316
PVDV	Additional charge for vibrated top (per LM)	393
BPM	Mirror polished front edge (per LM)	162
PVBC	Additional charge for each additional level with cutlery tray (per level)	308
MVBC	Deduction when purchasing 1 fewer cutlery tray level	-299
PVBP	Additional charge for each additional level with bread tray (per level)	393
MVPB	Deduction when purchasing 1 fewer bread tray level	-377
PVGRI	Additional charge for each additional grid	291
MVGRI	Deduction when purchasing 1 fewer grid	-269
PVCA	Additional charge for each additional level with tray rack (per level).	308
MVCA	Deduction when purchasing 1 fewer rack	-279
PVFSPE	Additional charge for loose unit fixings	128

02

**COLD
UNITS**

Enodis
ADULT

**Easy'
Serve**

Technical Information

- **All AISI 304 (18-10) stainless steel** construction .
- AISI 304 stainless steel **top thickness 2 mm** with 220 grain satin polish (**scotch-brite**).
Customer side counter surface profile 20 mm rounded edge with **110 mm drop**.
Service side counter surface straight edge with **60 mm drop**.
Available as add-on: granite or reconstituted stone top thickness 30 mm (one piece per unit).
Granite or reconstituted stone top finished with straight edge on service side and end and rounded edge on customer side.
- Depth 830 mm, height 900 mm on stainless steel base height 180 mm adjustable -25/+50 mm.
- Units must be bolted at front and rear with sealant between **clean edge** panelling.
- Tray slide brackets in AISI 304 stainless steel fitted to frame through laminated front to ensure tray slide is fully aligned.
- **Standard stainless steel tray rail 3 profiled bars diameter 32 mm (included in unit price)**.
Available as add-on: granite rail, reconstituted stone rail, glass rail or laminate rail.
- Customer side **façade** as standard in **water-repellent melamine** coated in double-sided laminate **thickness 20 mm. 15 mm elevation** with lower stainless steel corner guard.
Available on request: 180 mm to 15 mm façade elevation with lower stainless steel corner guard.
Panels are fitted with an interlocking clip system and held in place by brackets.
Service side fascia panel attached with easily removable screws for access.
- **250 colours** to choose from our colour chart.

Specifications

- **Refrigerated tank with static cooling** with welded rounded corners and diamond pattern toward drain plug. Injected with polyurethane foam insulation. Available with **30 mm or 110 mm recess**. Temperature range -10°C to 5°C.
- **Refrigerated tank with ventilated cooling** with welded rounded corners and diamond pattern toward drain plug. Injected with polyurethane foam insulation.
Available with **30 mm or 110 mm recess**. Temperature range -10°C to 5°C.
- **Refrigerated storage cabinets with ventilated cooling** and isothermal insulating drawer units with HCFO foam, density 42 kg/m³, thickness 60 mm. Temperature range 1°C to 8°C
- Stainless steel door with removable lip seal. Lower drawer units with 5 levels of runners for GN1/1 or GN2/1 spaced 70 mm apart (or 3 levels depending on model).
- **Refrigeration system noise level 56dB(A)**. Uses refrigerant **R455A** (GWP of 146), power supply single-phase 230 volts. **Comes with removable frame**.
- Drip tray included.
- Touch-key controls.
Available as add-on: Easy'Touch control panel.
- Other refrigerants available on request: R290.
- Compatible remote units: CO₂, R134A, R404A, R407F, R448A, R449A, R452A, R513A, glycolated water (please confirm fluid when placing your order).

Complies with AFNOR standard AC D 40-004 (the French industrial standards authority).

Our most **Enodis** **ADULT** **Easy'** **Serve**

POPULAR PRODUCTS

Refrigerated display units for starters, drinks or salad'bar refrigerated tank for starters, drinks and displaying food on ice

Trays cooled using copper coiling located under the tank with HCFO foam insulation, density 42kg/m³.
Compatible with GN1/1 trays.

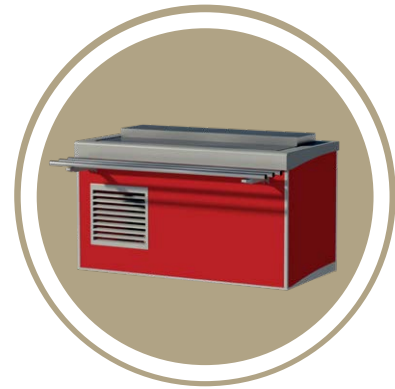

Display counters

Polished stainless steel bars diameter 40 mm.
Tempered glass shelf with curved sneeze guard thickness 6 mm. LED lighting (some models only)

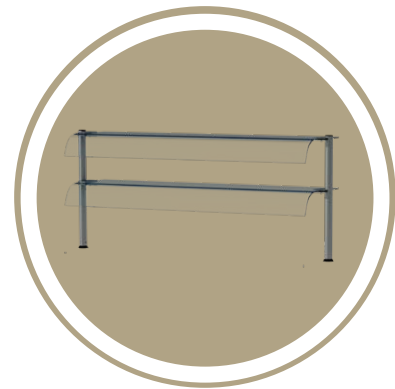

Refrigerated display with ventilated tank and salad'bar.

Ventilated tank, base in 2 depth-adjustable parts (30 to 110 mm), GN1/1 tray compatible.
Oscillating ventilated evaporator.
HCFO foam insulation, density 42kg/m³.
Bactericidal UVC lamp available as add-on.
Potentiometer for fan control to optimise operation and energy consumption.
Tempered glass shelf with curved sneeze guard on both sides, thickness 6 mm.
Tray slide with stainless steel bars diameter 32 mm.

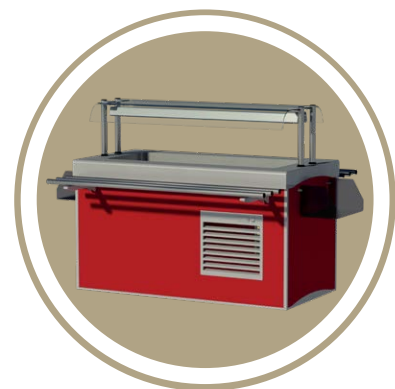

Our most

POPULAR PRODUCTS

Endis
ADULT
Easy'
Serve

“Cristaline” display units

Ventilated tank, base in 2 depth-adjustable parts from 30 to 110 mm, GN1/1 tray compatible (oscillating ventilated evaporator). HCFO foam insulation, density 42 kg/m³. Potentiometer for fan control to optimise operation and energy consumption. Rectangular refrigerated display cabinet with rear ventilation. Customer side open with thermal curtain. Available as add-on: curved glass cover on hydraulic cylinders for easy lifting and cleaning. 2 sliding doors in double-walled Plexiglas with micro-perforations to allow laminar airflow with front suction to form the air curtain. 2, 3 or 4 height-adjustable shelves (depending on model). LED lighting.

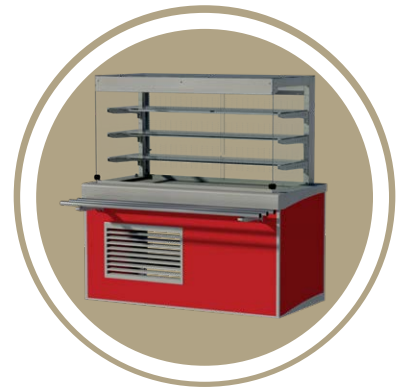

“Élégance” display units

Ventilated tank, base in 2 depth-adjustable parts (30 to 110 mm), GN1/1 compatible (oscillating ventilated evaporator). HCFO foam insulation, density 42 kg/m³. Potentiometer for fan control to optimise operation and energy consumption. Rounded refrigerated display cabinet with rear ventilation. Customer side open with thermal curtain. Add-on: curved glass cover on hydraulic cylinders for easy lifting and cleaning. 2 sliding doors in double-walled Plexiglas with micro-perforations to allow laminar airflow with front suction to form the air curtain. 2 or 3 height-adjustable shelves (depending on model). LED lighting.

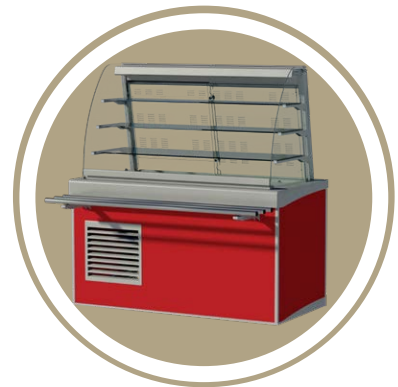

“Classique” display units

Trays refrigerated using copper coiling located under the tank with HCFO foam insulation, density 42 kg/m³. Display cabinet with insulated box in top and ventilated evaporator. Front-flow refrigeration and rear air return. Tempered glass sliding doors on service side and fridge roller blind on customer side. Tempered double glazing on both sides. LED lighting on customer side. Compatible with GN1/1 trays.

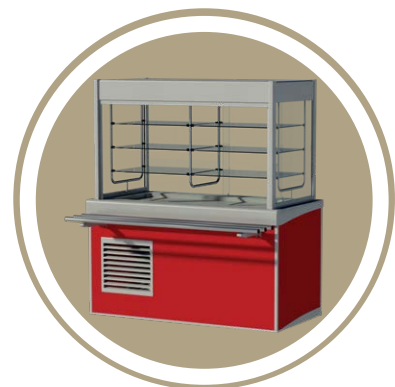

REFRIGERATED UNIT ON OPEN CUPBOARD WITH STATIC COOLING

Enodis
ADULT

Easy'
Serve



on open cupboard



container depth 30 mm

DESCRIPTION

AISI 304 stainless steel structure. AISI 304 stainless steel top thickness 2 mm. Rounded front edge. Laminate exterior. 15 mm elevation. Includes 3 stainless steel handrails. Recessed tank, depth 30 mm, drains directly (draining 3/4), condensate drip tray (4 L). Static refrigeration using copper coiling located under the tank with HCFO foam insulation. 240 v single-phase power supply. Noise level with refrigeration unit 56 dB(A). Comes with removable frame. Refrigerant R455A Adjustable tank control. Touch-key controls.

Available without refrigeration unit (comes with vacuum pump, control facility, pressure regulator and evaporator).

*Add SG to item number. Ex. MSGHL12DES. Condensate drip tray not included.

Refrigerated units on open cupboard for starters and desserts

Item no.	Tank	Power (w)	Power (w)	Length	With refrigeration unit Price in € (plus VAT)	Without refrigeration unit* Price in € (plus VAT)
	Tray capacity	Electric	Cooling capacity (W)		Stainless steel top	Stainless steel top
MHL12DES	3 GN1/1	350	377	1,200/1,250*	7,058	6,181
MHL16DES	4 GN1/1	450	562	1,600	7,976	7,046
MHL20DES	5 GN1/1	700	753	2,000	8,690	7,669
MHL23DES	6 GN1/1	700	753	2,300	9,286	8,246

Ask us about our plan stone and granite tops.

REFRIGERATED UNITS WITH STATIC COOLING AND REFRIGERATED STORAGE

Enodis
ADULT

Easy'
Serve

COLD UNITS



with storage (1 door)



container depth 30 mm

DESCRIPTION

AISI 304 stainless steel structure. AISI 304 stainless steel top thickness 2 mm. Rounded front edge. Laminate exterior. 15 mm elevation. Includes 3 stainless steel handrails. Recessed tank, depth 30 mm, drains directly (3/4 draining), condensate drip tray (4 litres). Static refrigeration using copper coiling located under the tank with HCFO foam insulation. 240 v single-phase power supply. Noise level with refrigeration unit 56 dB(A). Comes with removable frame. Refrigerant R455A Dual adjustable control (tank and storage area. Touch-key controls.

Units with storage: stainless steel door(s) with removable lip seal. With 5 grids for GN1/1 or GN2/1 trays (trays not included).

Available without refrigeration unit (comes with vacuum pump, control facility, pressure regulator and evaporator).

*Add SG to item number. Condensate drip tray not included.

Refrigerated units with refrigerated storage for starters and desserts

Item no.	Refrigerated storage	Tank Tray capacity	Power (w)		Length	With refrigeration unit	Without refrigeration unit*
			Electric	Cooling capacity (W)		Price in € (plus VAT) Stainless steel top	Price in € (plus VAT) Stainless steel top
MHR12DES	1 x GN2/1 door	3 GN1/1	350	377	1,200/1,250*	10,165	6,156
MHR16DES	1 x GN2/1 door	4 GN1/1	450	562	1,600	10,695	9,848
MHR20DES	2 x GN2/1 doors	5 GN1/1	700	753	2,000	12,721	11,786
MHR23DES	2 x GN2/1 doors	6 GN1/1	700	753	2,300	13,323	12,368

Ask us about our plan stone and granite tops.

REFRIGERATED UNIT ON OPEN CUPBOARD WITH STATIC COOLING

Enodis
ADULT

Easy'
Serve



on open cupboard



container depth 110 mm

DESCRIPTION

AISI 304 stainless steel structure. AISI 304 stainless steel top thickness 2 mm. Rounded front edge. Laminate exterior. 15 mm elevation. Includes 3 stainless steel handrails. Recessed tank, depth 110 mm, drains directly (3/4 draining), condensate drip tray (4 litres). Static refrigeration using copper coiling located under the tank with HCFO foam insulation. 240 v single-phase power supply. Noise level with refrigeration unit 56 dB(A). Comes with removable frame. Refrigerant R455A Adjustable tank control. Touch-key controls.

Available without refrigeration unit (comes with vacuum pump, control facility, pressure regulator and evaporator).

*Add SG to item number. Ex. MSGBL12DES. Condensate drip tray not included.

Refrigerated beverage units on open cupboard

Item no.	Tank	Power (w)	Power (w)	Length	With refrigeration unit Price € (plus VAT)	Without refrigeration unit* Price in € (plus VAT)
	Tray capacity	Electric	Cooling capacity (W)		Stainless steel top	Stainless steel top
MBL12DES	3 GN1/1	350	377	1,200/1,250*	7,445	6,584
MBL16DES	4 GN1/1	450	562	1,600	8,365	7,533
MBL20DES	5 GN1/1	700	753	2,000	9,173	8,153
MBL23DES	6 GN1/1	700	753	2,300	9,749	8,709

Ask us about our plan stone and granite tops.

REFRIGERATED UNITS WITH STATIC COOLING AND REFRIGERATED STORAGE

Enodis
ADULT

Easy'
Serve



with storage (1 door)

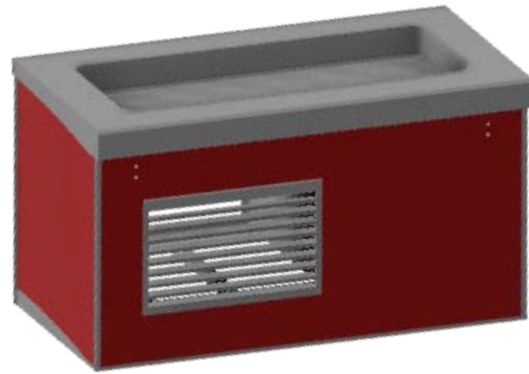

container depth 110 mm

DESCRIPTION

AISI 304 stainless steel structure. AISI 304 stainless steel top thickness 2 mm. Rounded front edge. Laminate exterior. 15 mm elevation. Includes 3 stainless steel handrails. Recessed tank, depth 110 mm, drains directly (3/4 draining), condensate drip tray (4 litres). Static refrigeration using copper coiling located under the tank with HCFO foam insulation. 240 v single-phase power supply. Noise level with refrigeration unit 56 dB(A). Comes with removable frame. Refrigerant R455A Dual adjustable control (tank and storage area). Touch-key controls.

Units with storage: stainless steel door(s) with removable lip seal. With 5 grids for GN1/1 or GN2/1 trays (not included).

Available without refrigeration unit (comes with vacuum pump, control facility, pressure regulator and evaporator).

Add SG to item number. Drip tray not included.*

Refrigerated beverage units with refrigerated storage

Item no.	Refrigerated storage	Tank Tray capacity	Power (w)		Length	With refrigeration unit	Without refrigeration unit*
			Electric	Cooling capacity (W)		Price in € (plus VAT)	Price in € (plus VAT)
						Stainless steel top	Stainless steel top
MBR12DES	1 x GN2/1 door	3 GN1/1	350	377	1,200/1,250*	7,901	6,598
MBR16DES	1 x GN2/1 door	4 GN1/1	450	562	1,600	11,096	10,242
MBR20DES	2 x GN2/1 doors	5 GN1/1	700	753	2,000	13,205	12,269
MBR23DES	2 x GN2/1 doors	6 GN1/1	700	753	2,300	13,786	12,831

Ask us about our plan stone and granite tops.

REFRIGERATED UNITS ON OPEN CUPBOARD WITH VENTILATED COOLING

Enodis
ADULT

Easy'
Serve

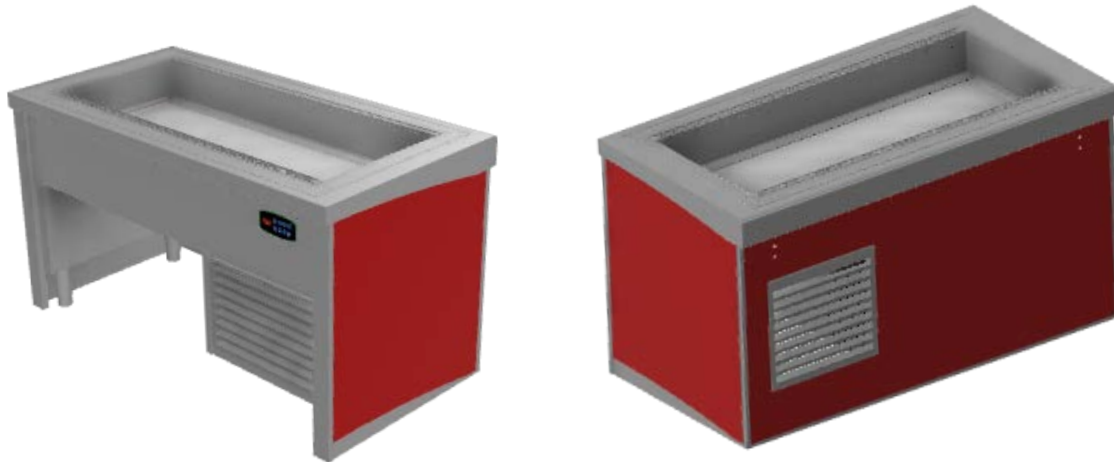

on open cupboard

tank depth 30 to 110 mm

DESCRIPTION

AISI 304 stainless steel structure. AISI 304 stainless steel top thickness 2 mm. Rounded front edge. Laminate façade with 15 mm elevation. Includes 3-bar stainless steel handrail. Ventilated tank, base in 2 depth-adjustable parts (30 to 110 mm), GN1/1 compatible (oscillating ventilated evaporator) HCFO foam insulation. Adjustable tank control. Touch-key controls. Noise level with refrigeration unit 56 dB(A). Comes with removable frame. Refrigerant R455A 240 v single-phase power supply. Potentiometer for fan control to optimise operation and energy consumption. Operating temperature: 2°C/10°C. Condensate drip tray system included.

Available without refrigeration unit (comes with vacuum pump, control facility, pressure regulator and evaporator).

*Add SG to item number. Condensate drip tray not included.

Refrigerated units for starters, desserts & drinks ventilated tank on open cupboard

Item no.	Tank	Power (w)	Power (w)	Length	With refrigeration unit Price € (plus VAT)	Without refrigeration unit* Price in € (plus VAT)
	Tray capacity	Electric	Cooling capacity (W)		Stainless steel top	Stainless steel top
MFVL12ES	3 GN1/1	900	1,166	1,250	13,384	12,005
MFVL16ES	4 GN1/1	1,200	1,573	1,600	14,049	12,435
MFVL20ES	5 GN1/1	1,400	1,717	2,000	15,337	13,736
MFVL23ES	6 GN1/1	1,600	1,911	2,300	16,955	14,955

Ask us about our plan stone and granite tops.

REFRIGERATED UNITS WITH VENTILATED COOLING AND REFRIGERATED STORAGE

Enodis
ADULT

Easy'
Serve

COLD UNITS



with storage (1 door)

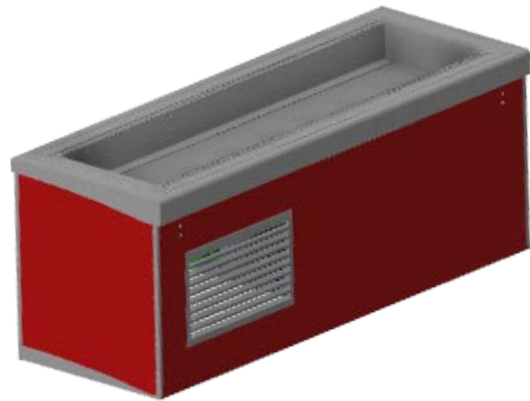

tank depth 30 to 110 mm

DESCRIPTION

AISI 304 stainless steel structure. AISI 304 stainless steel top thickness 2 mm. Rounded front edge. Laminate exterior. 15 mm elevation. Includes 3 stainless steel handrails. Ventilated tank, base in 2 depth-adjustable parts (30 to 110 mm), GN1/1 compatible (oscillating ventilated evaporator). HCFO foam insulation. Adjustable tank control. Touch-key controls. Noise level with refrigeration unit 56 dB(A). Comes with removable frame. Refrigerant R455A 240 v single-phase power supply. Potentiometer for fan control to optimise operation and energy consumption. Operating temperature: 2°C/10°C. Condensate drip tray system included.

Available without refrigeration unit (comes with vacuum pump, control facility, pressure regulator and evaporator).

*Add SG to item number. Ex. MSGFVR12ES. Condensate drip tray not included.

Refrigerated units for starters, desserts & drinks ventilated tank with refrigerated storage

Item no.	Refrigerated storage	Tank Tray capacity	Power (w)		Length	With refrigeration unit	Without refrigeration unit*
			Electric	Cooling capacity (W)		Price in € (plus VAT) Stainless steel top	Price in € (plus VAT) Stainless steel top
MFVR14ES	GN1/1	3 GN1/1	900	1,166	1,400	15,460	14,080
MFVR16ES	GN2/1	4 GN1/1	1,200	1,573	1,600	15,092	14,234
MFVR20ES	GN2/1 + GN1/1	5 GN1/1	1,400	1,717	2,000	18,374	16,771
MFVR23ES	2 x GN2/1 doors	6 GN1/1	1,600	1,911	2,300	21,310	19,305

Ask us about our plan stone and granite tops.

REFRIGERATED DISPLAY COUNTERS

Enodis
ADULT

Easy'
Serve



single display counter



double display counter

DESCRIPTION

Display counter with 6 mm curved glass on 1 side. Polished stainless steel 40 mm bar. Height 370 mm with 1 level and 640 mm with 2. 240 v single-phase power supply. Available as add-on: under-shelf LED lighting strip or single/double lighting strip for double shelves.

Refrigerated display counters - 1 level

Length	GN capacity	Lighting wattage (per shelf)	Single shelf	
		LED	Item no.	Price in € (plus VAT)
800*	2	8	PICS08	691
1,200*	3	14	PICS12	711
1,600	4	20	PICS16	726
2,000	5	26	PICS20	1,038
2,300	6	30	PICS23	1,060

Single shelf (for each shelf) + LED lighting	
Item no.	Price in € (plus VAT)
PICS08LED	1,078
PICS12LED	1,236
PICS16LED	1,451
PICS20LED	1,667
PICS23LED	1,759

* Display counters with length of 800 can be fitted to 800 and 900 units. Display counters with length of 1,200 can be fitted to 1,200 and 1,250 units.

Refrigerated display counters - 2 levels

Length	GN capacity	Lighting wattage**	Double shelf	
		LED	Item no.	Price in € (plus VAT)
800*	2	8	PICD08	1,047
1,200*	3	14	PICD12	1,164
1,600	4	20	PICD16	1,191
2,000	5	26	PICD20	1,551
2,300	6	30	PICD23	1,798

Double shelf+ LED lighting 1 level	
Item no.	Price in € (plus VAT)
PICD08LED1	1,494
PICD12LED1	1,716
PICD16LED1	1,808
PICD20LED1	2,409
PICD23LED1	3,865

Double shelf+ LED lighting 2 levels	
Item no.	Price in € (plus VAT)
PICD08LED2	1,792
PICD12LED2	1,859
PICD16LED2	2,049
PICD20LED2	2,529
PICD23LED2	2,787

** Per shelf

* Display counters with length of 800 can be fitted to 800 and 900 units. Display counters with length of 1,200 can be fitted to 1,200 and 1,250 units.

1 & 2 LEVEL DISPLAY COUNTERS IN STAINLESS STEEL WITH SNEEZE GUARD

Enodis
ADULT

Easy'
Serve

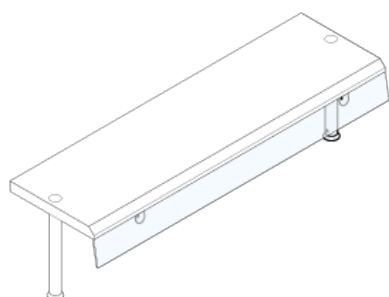

display counter 1 level

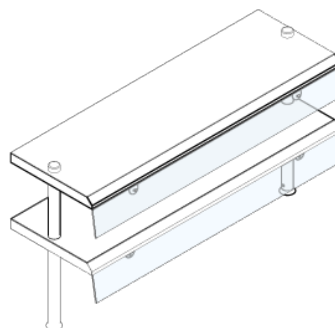

display counter 2 levels

DESCRIPTION

1.8 mm stainless steel display counters with straight glass sneeze guard in 6 mm white tempered glass.
Polished stainless steel bars diameter 40mm.
Height 370 mm with 1 level and 640 mm with 2. 240 v single-phase power supply.
Available as add-on: one or two under-shelf LED lighting strips for first and/or second shelf.

Stainless steel display counters with sneeze guard - 1 level

Length	GN capacity	Lighting wattage (per shelf)	Single shelf	
		LED	Item no.	Price in € (plus VAT)
800	2	8	PICS08-I	1,053
1,200	3	14	PICS12-I	1,170
1,600	4	20	PICS16-I	1,285
2,000	5	26	PICS20-I	1,634
2,300	6	30	PICS23-I	1,793

Single shelf (for each shelf) + LED lighting	
Item no.	Price in € (plus VAT)
PICS08LED-I	1,367
PICS12LED-I	1,603
PICS16LED-I	1,829
PICS20LED-I	2,303
PICS23LED-I	2,600

Stainless steel display counters with sneeze guard - 2 levels

Length	GN capacity	Lighting wattage	Double shelf		Double shelf+ LED lighting 1 level		Double shelf+ LED lighting 2 levels	
		LED	Item no.	Price in € (plus VAT)	Item no.	Price in € (plus VAT)	Item no.	Price in € (plus VAT)
800	2	8	PICD08-I	1,606	PICD08LED1-I	2,057	PICD08LED2-I	2,508
1,200	3	14	PICD12-I	1,780	PICD12LED1-I	2,372	PICD12LED2-I	2,965
1,600	4	20	PICD16-I	1,955	PICD16LED1-I	2,680	PICD16LED2-I	3,406
2,000	5	26	PICD20-I	2,481	PICD20LED1-I	3,381	PICD20LED2-I	4,279
2,300	6	30	PICD23-I	2,801	PICD23LED1-I	3,867	PICD23LED2-I	4,932

PVHP530: additional charge - height 530 mm = €171

RECTANGULAR SALAD'BAR WITH STATIC OR VENTILATED COOLING

Enodis
ADULT

Easy'
Serve



DESCRIPTION

AISI 304 stainless steel structure. AISI 304 stainless steel top thickness 2 mm. Rounded front edge. Laminate façade with 15 mm elevation. Includes 3-bar stainless steel handrail.

Recessed container, depth 30 mm or 110 mm, drains directly (3/4 draining). Static refrigeration using copper coiling located under the tank with HCFO foam insulation.

Ventilated tank, base in 2 depth-adjustable parts (30 to 110 mm), GN1/1 compatible (oscillating ventilated evaporator).

Noise level with refrigeration unit 56 dB(A). Comes with removable frame. Refrigerant R455A Touch-key controls.

Display counter with curved glass on both sides (6 mm) plus LED lighting as standard. 2 stainless steel sections on each side diameter 40 mm. Side shelves. Closed cabinet body to fit façade on 4 sides with refrigeration unit located at one end. Width: 1,470 mm with both handrails, height: 900 mm.

240 v single-phase power supply.

Available without refrigeration unit (comes with vacuum pump, control facility, pressure regulator and evaporator).

*Add SG to item number SBSGRB16ES. Condensate drip tray not included.

Salad'bar with static cooling - tank depth 30 mm

Item no.	Tank	Power (w)	Power (w)	Length	With refrigeration unit Price in € (plus VAT)	Without refrigeration unit* Price in € (plus VAT)
	Tray capacity	Electric	Cooling capacity (W)		Stainless steel top	Stainless steel top
SBRH16ES	4 GN1/1	450	562	1,600	10,007	9,025
SBRH20ES	5 GN1/1	700	753	2,000	11,306	10,261
SBRH23ES	6 GN1/1	700	753	2,300	12,239	11,076

Ask us about our plan stone and granite tops.

Salad'bar with static cooling - tank depth 110 mm

Item no.	Tank	Length	With refrigeration unit Price in € (plus VAT)	Without refrigeration unit* Price in € (plus VAT)
	Tray capacity		Stainless steel top	Stainless steel top
SBRB16ES	4 GN1/1	1600	10,392	9,787
SBRB20ES	5 GN1/1	2,000	11,523	10,888
SBRB23ES	6 GN1/1	2,300	12,432	11,296

Ask us about our plan stone and granite tops.

Salad'bar with ventilated cooling - tank depth 30 to 110 mm

Item no.	Tank	Power (w)	Power (w)	Length	With refrigeration unit Price in € (plus VAT)	Without refrigeration unit* Price in € (plus VAT)
	Tray capacity	Electric	Cooling capacity (W)		Stainless steel top	Stainless steel top
SBRV16ES	4 GN1/1	1,200	1,573	1,600	18,354	17,610
SBRV20ES	5 GN1/1	1,400	1,717	2,000	19,921	19,722
SBRV23ES	6 GN1/1	1,600	1,911	2,300	21,802	20,832

Ask us about our plan stone and granite tops.

OCTAGONAL SALAD'BAR WITH STATIC COOLING

Enodis
ADULT

Easy'
Serve

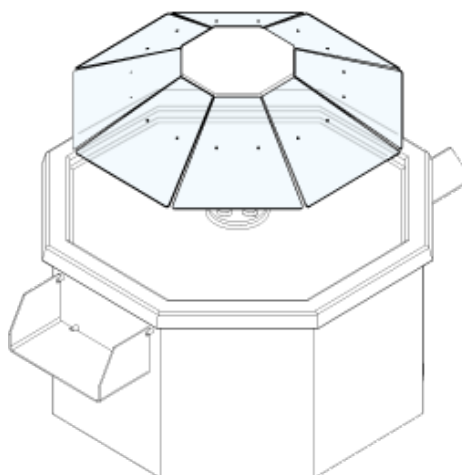

DESCRIPTION

AISI 304 stainless steel structure. AISI 304 stainless steel top thickness 2 mm. Rounded front edge. Laminate façade with 15 mm elevation. Includes 3-bar stainless steel handrail. Central octagonal display and self-service island with upper structure, sneeze guard, LED lighting and methacrylate lateral plate holders. Recessed tank, depth 50 mm, drains directly (3/4 draining). Static refrigeration using copper coiling located under the tank with HCFO foam insulation. Touch-key controls. Noise level with refrigeration unit 56 dB(A). Comes with removable frame. Refrigerant R455A Trays slides featuring 3 smooth bars (brushed stainless steel) diameter 32 fitted to stainless steel brackets (height 800 mm). Closed cabinet body to fit façade on 8 sides with refrigeration unit located at one end. Dimensions: 1,400 x 1,400 mm or 1,700 x 1,700 mm. 240 v single-phase power supply.

Unit not available in granite.

Available without refrigeration unit (comes with vacuum pump, control facility, pressure regulator and evaporator).

*Add SG to item number. Ex. SBSGOCTO14ES. Condensate drip tray not included.

Salad'bar with static cooling - recess depth 50 mm

Item no.	Power	Power	Length	With refrigeration unit	Without refrigeration unit*
	Electric	Cooling capacity (W)		Side	Price in € (plus VAT)
SBOCTO14ES	700	753	1,400	19,664	18,483
SBOCTO18ES	800	1,166	1,600	21,328	20,170

Ask us about our motorised display counter

OCTAGONAL SALAD'BAR ADD-ONS		
Item no.	Name	Price in € (plus VAT)
MOTOR	Motorised	Please ask us

“CRISTALINE” REFRIGERATED DISPLAY CABINETS ON OPEN CUPBOARD WITH 2 LEVELS, VENTILATED COOLING AND REAR AIRFLOW SYSTEM

Enodis
ADULT



on open cupboard



tank depth 30 to 110 mm

DESCRIPTION

AISI 304 stainless steel structure. AISI 304 stainless steel top thickness 2 mm. Rounded front edge. Laminate façade with 15 mm elevation. Includes 3-bar stainless steel handrail. Ventilated tank, base in 2 depth-adjustable parts (30 to 110 mm), GN1/1 compatible (oscillating ventilated evaporator) Noise level with refrigeration unit 56 dB(A). Comes with removable frame. Refrigerant R455A HCFO foam insulation. Potentiometer for fan control to optimise operation and energy consumption. Adjustable control for the display cabinet. Touch-key controls.

Rectangular refrigerated display cabinet with rear ventilation. Customer side open with thermal curtain. Add-on: curved glass cover on hydraulic cylinders for easy lifting and cleaning. 2 sliding doors in double-walled Plexiglas with micro-perforations to allow laminar airflow with front suction to form the air curtain. 2 height-adjustable shelves. LED lighting. Operating temperature: 2°C/10°C. Condensate drip tray system included. Power supply 240 v single-phase (except models with 2,600 length, which have 400 v 3-phase). Adult unit height: 1,510 mm. *Add SG to item number. Condensate drip tray not included.

“Cristaline” refrigerated display cabinets on open cupboard with 2 levels, ventilated cooling and rear airflow system

Item no.	Tank	Cooling capacity (w)	Length	With refrigeration unit Price in € (plus VAT)	Without refrigeration unit* Price in € (plus VAT)
	Tray capacity			Stainless steel top	Stainless steel top
VO2CL09ES	2 GN1/1	800 / 972	950	16,057	13,760
VO2CL12ES	3 GN1/1	900 / 1,166	1,250	16,822	15,225
VO2CL16ES	4 GN1/1	1,200 / 1,573	1,600	19,087	17,183
VO2CL20ES	5 GN1/1	1,400 / 1,717	2,000	20,991	19,068
VO2CL23ES	6 GN1/1	1,600 / 1,911	2,300	24,605	22,647

Ask us about our plan stone and granite tops.

“CRISTALINE” REFRIGERATED DISPLAY CABINETS WITH 2 LEVELS, VENTILATED COOLING, REAR AIRFLOW SYSTEM AND REFRIGERATED STORAGE

Enodis
ADULT

Easy'
Serve

COLD UNITS



with refrigerated storage



tank depth 30 to 110 mm

DESCRIPTION

AISI 304 stainless steel structure. AISI 304 stainless steel top thickness 2 mm. Rounded front edge. Laminate façade with 15 mm elevation. Includes 3-bar stainless steel handrail. Ventilated tank, base in 2 depth-adjustable parts (30 to 110 mm), GN1/1 compatible (oscillating ventilated evaporator) Noise level with refrigeration unit 56 dB(A). Comes with removable frame. Refrigerant R455A HCFO foam insulation. Potentiometer for fan control to optimise operation and energy consumption. Dual adjustable control (display cabinet and storage area). Touch-key controls. Rectangular refrigerated display cabinet with rear ventilation. Customer side open with thermal curtain. Add-on: curved glass cover on hydraulic cylinders for easy lifting and cleaning. 2 sliding doors in double-walled Plexiglas with micro-perforations to allow laminar airflow with front suction to form the air curtain. 2 height-adjustable shelves. LED lighting. Operating temperature: 2°C/10°C. Condensate drip tray system included. Lower refrigerated storage area with 2 grids with 3 levels each for GN1/1 or 2/1 trays spaced 70 mm apart (GN trays not included). Stainless steel door(s) with removable lip seal. Power supply 240 v single-phase (except models with 2600 length, which have 400 v 3-phase). Adult unit height: 1,510 mm. Available without refrigeration unit (comes with vacuum pump, control facility, pressure regulator and evaporator).
*Add SG to item number. Condensate drip tray not included.

“Cristaline” refrigerated display cabinets with 2 levels, ventilated cooling, rear airflow system and refrigerated storage

Item no.	Tank Tray capacity	Refrigerated storage	Cooling capacity (w)	Length	With refrigeration unit	Without refrigeration unit*
					Price in € (plus VAT)	Price in € (plus VAT)
					Stainless steel top	Stainless steel top
VO2CR14ES	3 GN 1/1	1 x GN1/1 door	1,200 / 1,543	1,400	19,093	15,570
VO2CR16ES	4 GN 1/1	1 x GN2/1 door	1,500 / 1,752	1,600	21,943	16,288
VO2CR20ES	5 x GN 1/1	1 door GN2/1 + GN1/1	1,700 / 2,094	2,000	24,862	18,264
VO2CR23ES	6 x GN 1/1	2 x GN2/1 doors	1,900 / 2,288	2,300	28,571	22,186

Ask us about our plan stone and granite tops.

“CRISTALINE” REFRIGERATED DISPLAY CABINETS ON OPEN CUPBOARD WITH 3 LEVELS, VENTILATED COOLING AND REAR AIRFLOW SYSTEM

Enodis
ADULT



on open cupboard



tank depth 30 to 110 mm

DESCRIPTION

AISI 304 stainless steel structure. AISI 304 stainless steel top thickness 2 mm. Rounded front edge. Laminate façade with 15 mm elevation. Includes 3-bar stainless steel handrail. Ventilated tank, base in 2 depth-adjustable parts (30 to 110 mm), GN1/1 compatible (oscillating ventilated evaporator) HCFO foam insulation. Noise level with refrigeration unit 56 dB(A). Comes with removable frame. Refrigerant R455A. Potentiometer for fan control to optimise operation and energy consumption. Adjustable control for the display cabinet. Touch-key controls.

Rectangular refrigerated display cabinet with rear ventilation. Customer side open with thermal curtain. Add-on: curved glass cover on hydraulic cylinders for easy lifting and cleaning. 2 sliding doors in double-walled Plexiglas with micro-perforations to allow laminar airflow with front suction to form the air curtain. 3 height-adjustable shelves. LED lighting. Operating temperature: 2°C/10°C. Condensate drip tray system included. Power supply 240 v single-phase (except models with 2,600 length, which have 400 v 3-phase). Adult unit height: 1,710 mm.

Available without refrigeration unit (comes with vacuum pump, control facility, pressure regulator and evaporator).

*Add SG to item number. Condensate drip tray not included.

“Cristaline” refrigerated display cabinets on open cupboard with 3 levels, ventilated cooling and rear airflow system

Item no.	Tank	Cooling capacity (w)	Length	With refrigeration unit Price in € (plus VAT)	
	Tray capacity			Stainless steel top	
VO3CL09ES	2 GN1/1	800 / 972	950	16,485	
VO3CL12ES	3 GN1/1	900 / 1,166	1,250	17,586	
VO3CL16ES	4 GN1/1	1,200 / 1,573	1,600	19,777	
VO3CL20ES	5 GN1/1	1,400 / 1,717	2,000	21,860	
VO3CL23ES	6 GN1/1	1,600 / 1,911	2,300	25,812	
VO3CL26ES	7 GN1/1	3,840 / 5,040	2,600	32,763	

Without refrigeration unit* Price in € (plus VAT)	
Stainless steel top	
14,820	
15,809	
16,577	
17,897	
21,193	
26,900	

Ask us about our plan stone and granite tops.

“CRISTALINE” REFRIGERATED DISPLAY CABINETS WITH 3 LEVELS, VENTILATED COOLING, REAR AIRFLOW SYSTEM AND REFRIGERATED STORAGE

Enodis
ADULT

Easy'
Serve

COLD UNITS



with storage



tank depth 30 to 110 mm

DESCRIPTION

AISI 304 stainless steel structure. AISI 304 stainless steel top thickness 2 mm. Rounded front edge. Laminate façade with 15 mm elevation. Includes 3-bar stainless steel handrail. Ventilated tank, base in 2 depth-adjustable parts (30 to 110 mm), GN1/1 compatible (oscillating ventilated evaporator) Noise level with refrigeration unit 56 dB(A). Comes with removable frame. Refrigerant R455A. HCFO foam insulation. Potentiometer for fan control to optimise operation and energy consumption. Dual adjustable control (display cabinet and storage area). Touch-key controls. Rectangular refrigerated display cabinet with rear ventilation. Customer side open with thermal curtain. Add-on: curved glass cover on hydraulic cylinders for easy lifting and cleaning. 2 sliding doors in double-walled Plexiglas with micro-perforations to allow laminar airflow with front suction to form the air curtain. 3 height-adjustable shelves. LED lighting. Operating temperature: 2°C/10°C. Condensate drip tray system included. Lower refrigerated storage area with 2 grids with 3 levels each for GN1/1 or 2/1 trays spaced 70 mm apart (GN trays not included). Stainless steel door(s) with removable lip seal. Power supply 240 v single-phase (except models with 2,600 length, which have 400 v 3-phase). Adult unit height: 1,710 mm. Available without refrigeration unit (comes with vacuum pump, control facility, pressure regulator and evaporator). *Add SG to item number. Condensate drip tray not included.

“Cristaline” refrigerated display cabinets with 3 levels, ventilated cooling, rear airflow system and refrigerated storage

Item no.	Tank	Refrigerated storage	Cooling capacity (w)	Length	With refrigeration unit	Without refrigeration unit*
	Tray capacity				Price in € (plus VAT)	Price in € (plus VAT)
					Stainless steel top	Stainless steel top
VO3CR14ES	3 GN 1/1	1 x GN1/1 door	1,200 / 1,543	1,400	20,361	16,508
VO3CR16ES	4 GN 1/1	1 x GN2/1 door	1,500 / 1,950	1,600	22,624	17,137
VO3CR20ES	5 x GN 1/1	1 door GN2/1 + GN1/1	1,700 / 2,094	2,000	25,762	19,316
VO3CR23ES	6 x GN 1/1	2 x GN2/1 doors	1,900 / 2,288	2,300	29,886	23,219
VO3CR26ES	7 GN 1/1	2 x GN2/1 doors	3,900 / 5,417	2,600	36,851	28,630

Ask us about our plan stone and granite tops.

“CRISTALINE” REFRIGERATED DISPLAY CABINETS ON OPEN CUPBOARD WITH 4 LEVELS, VENTILATED COOLING AND REAR AIRFLOW SYSTEM

Enodis
ADULT



on open cupboard



tank depth 30 to 110 mm

DESCRIPTION

AISI 304 stainless steel structure. AISI 304 stainless steel top thickness 2 mm. Rounded front edge. Laminate façade with 15 mm elevation. Includes 3-bar stainless steel handrail. Ventilated tank, base in 2 depth-adjustable parts (30 to 110 mm), GN1/1 compatible (oscillating ventilated evaporator) Noise level with refrigeration unit 56 dB(A). Comes with removable frame. Refrigerant R455A. HCFO foam insulation. Potentiometer for fan control to optimise operation and energy consumption. Adjustable control for the display cabinet.

Touch-key controls.

Rectangular refrigerated display cabinet with rear ventilation. Customer side open with thermal curtain. Add-on: curved glass cover on hydraulic cylinders for easy lifting and cleaning. 2 sliding doors in double-walled Plexiglas with micro-perforations to allow laminar airflow with front suction to form the air curtain. 4 height-adjustable shelves. LED lighting. Operating temperature: 2°C/10°C. Condensate drip tray system included. Power supply 240 v single-phase (except models with 2,600 length, which have 400 v 3-phase).

Adult unit height: 1,910 mm. *Add SG to item number. Condensate drip tray not included.

“Cristaline” refrigerated display cabinets on open cupboard with 4 levels, ventilated cooling and rear airflow system

Item no.	Tank	Cooling capacity (w)	Length	With refrigeration unit Price in € (plus VAT)	Without refrigeration unit* Price in € (plus VAT)
	Tray capacity			Stainless steel top	Stainless steel top
VO4CL09ES	2 GN1/1	800 / 972	950	18,135	14,843
VO4CL12ES	3 GN1/1	900 / 1,166	1,250	19,331	16,519
VO4CL16ES	4 GN1/1	1,200 / 1,573	1,600	19,573	18,413
VO4CL20ES	5 GN1/1	1,400 / 1,717	2,000	21,700	20,937
VO4CL23ES	6 GN1/1	1,600 / 1,911	2,300	23,919	24,335
VO4CL26ES	7 GN1/1	3,600 / 5,040	2,600	31,679	29,648

Ask us about our plan stone and granite tops.

“CRISTALINE” REFRIGERATED DISPLAY CABINETS WITH 4 LEVELS, VENTILATED COOLING, REAR AIRFLOW SYSTEM AND REFRIGERATED STORAGE

Enodis
ADULT

Easy'
Serve

COLD UNITS



with refrigerated storage



tank depth 30 to 110 mm

DESCRIPTION

AISI 304 stainless steel structure. AISI 304 stainless steel top thickness 2 mm. Rounded front edge. Laminate façade with 15 mm elevation. Includes 3-bar stainless steel handrail. Ventilated tank, base in 2 depth-adjustable parts (30 to 110 mm), GN1/1 compatible (oscillating ventilated evaporator) Noise level with refrigeration unit 56 dB(A). Comes with removable frame. Refrigerant R455A. HCFO foam insulation. Potentiometer for fan control to optimise operation and energy consumption. Dual adjustable control (display cabinet and storage area). Touch-key controls. Rectangular refrigerated display cabinet with rear ventilation. Customer side open with thermal curtain. Add-on: curved glass cover on hydraulic cylinders for easy lifting and cleaning. 2 sliding doors in double-walled Plexiglas with micro-perforations to allow laminar airflow with front suction to form the air curtain. 4 height-adjustable shelves. LED lighting. Operating temperature: 2°C/10°C. Condensate drip tray system included. Lower refrigerated storage area with 2 grids with 3 levels each for GN1/1 or 2/1 trays spaced 70 mm apart (GN trays not included). Stainless steel door(s) with removable lip seal. Power supply 240 v single-phase (except models with 2,600 length, which have 400 v 3-phase). Adult unit height: 1,910 mm. *Add SG to item number. Condensate drip tray not included.

“Cristaline” refrigerated display cabinets with 4 levels, ventilated cooling, rear airflow system and refrigerated storage

Item no.	Tank	Refrigerated storage	Cooling capacity (w)	Length	With refrigeration unit	Without refrigeration unit*
	Tray capacity				Price in € (plus VAT)	Price in € (plus VAT)
					Stainless steel top	Stainless steel top
VO4CR14ES	3 GN 1/1	1 x GN1/1 door	1,200 / 1,543	1,400	21,786	
VO4CR16ES	4 GN 1/1	1 x GN2/1 door	1,500 / 1,950	1,600	22,200	
VO4CR20ES	5 x GN 1/1	1 door GN2/1 + GN1/1	1,700 / 2,094	2,000	24,577	
VO4CR23ES	6 x GN 1/1	2 x GN2/1 doors	1,900 / 2,288	2,300	27,137	

Ask us about our plan stone and granite tops.

“ÉLÉGANCE” REFRIGERATED DISPLAY CABINETS ON OPEN CUPBOARD WITH 2 LEVELS, VENTILATED COOLING AND REAR AIRFLOW SYSTEM

Enodis
ADULT



on open cupboard



tank depth 30 to 110 mm

DESCRIPTION

AISI 304 stainless steel structure. AISI 304 stainless steel top thickness 2 mm. Rounded front edge. Laminate façade with 15 mm elevation. Includes 3-bar stainless steel handrail. Ventilated tank, base in 2 depth-adjustable parts (30 to 110 mm), GN1/1 compatible (oscillating ventilated evaporator) Noise level with refrigeration unit 56 dB(A). Comes with removable frame. Refrigerant R455A. HCFO foam insulation. Potentiometer for fan control to optimise operation and energy consumption. Adjustable control for the display cabinet. Touch-key controls.

Rounded refrigerated display cabinet with rear ventilation. Customer side open with thermal curtain. Curved glass cover on hydraulic cylinders for easy lifting and cleaning available as add-on. 2 sliding doors in double-walled Plexiglas with micro-perforations to allow laminar airflow with front suction to form the air curtain. 2 height-adjustable shelves. LED lighting. Operating temperature: 2°C/10°C. Condensate drip tray system included. 240 v single-phase power supply. Adult unit height: 1,500 mm.

Available without refrigeration unit (comes with vacuum pump, control facility, pressure regulator and evaporator), ex.

*Add SG to item number. Condensate drip tray not included.

“Élégance” refrigerated display cabinets on open cupboard with 2 levels, ventilated cooling and rear airflow system

Item no.	Tank	Cooling capacity (w)	Length	With refrigeration unit	Without refrigeration unit*
	Tray capacity			Price in € (plus VAT)	Price in € (plus VAT)
				Stainless steel top	Stainless steel top
VO2AL09ES	2 GN1/1	800 / 972	950	16,057	13,713
VO2AL12ES	3 GN1/1	900 / 1,166	1,250	16,822	15,104
VO2AL16ES	4 GN1/1	1,200 / 1,573	1,600	18,800	16,897
VO2AL20ES	5 GN1/1	1,400 / 1,717	2,000	20,689	20,030

Ask us about our plan stone and granite tops.

“ÉLÉGANCE” REFRIGERATED DISPLAY CABINETS WITH 2 LEVELS, VENTILATED COOLING, REAR AIRFLOW SYSTEM AND REFRIGERATED STORAGE

Enodis
ADULT

Easy'
Serve

COLD UNITS



with storage (1 door)



tank depth 30 to 110 mm

DESCRIPTION

AISI 304 stainless steel structure. AISI 304 stainless steel top thickness 2 mm. Rounded front edge. Laminate façade with 15 mm elevation. Includes 3-bar stainless steel handrail. Ventilated tank, base in 2 depth-adjustable parts (30 to 110 mm), GN1/1 compatible (oscillating ventilated evaporator) Noise level with refrigeration unit 56 dB(A). Comes with removable frame. Refrigerant R455A. HCFO foam insulation. Potentiometer for fan control to optimise operation and energy consumption. Dual adjustable control (display cabinet and storage area). Touch-key controls. Rounded refrigerated display cabinet with rear ventilation. Customer side open with thermal curtain. Curved glass cover on hydraulic cylinders for easy lifting and cleaning available as add-on. 2 sliding doors in double-walled Plexiglas with micro-perforations to allow laminar airflow with front suction to form the air curtain. 2 height-adjustable shelves. LED lighting.

Operating temperature: 2°C/10°C. Condensate drip tray system included.

Lower refrigerated storage area with 2 grids with 3 levels each for GN1/1 or 2/1 trays spaced 70 mm apart (GN trays not included). Stainless steel door(s) with removable lip seal. 240 v single-phase power supply.

Adult unit height: 1,500 mm.

Available without refrigeration unit (comes with vacuum pump, control facility, pressure regulator and evaporator), ex.

*Add SG to item number. Condensate drip tray not included.

“Élégance” refrigerated display cabinets with 2 levels, ventilated cooling, rear airflow system and refrigerated storage

Item no.	Tank Tray capacity	Refrigerated storage	Cooling capacity (w)	Length	With refrigeration unit	Without refrigeration unit*
					Price in € (plus VAT)	Price in € (plus VAT)
					Stainless steel top	Stainless steel top
VO2AR14ES	2 x GN 1/1	1 x GN1/1 door	1,200 / 1,543	950	19,476	15,882
VO2AR16ES	3 GN 1/1	1 x GN2/1 door	1,500 / 1,950	1,250	21,656	16,614
VO2AR20ES	4 GN 1/1	1 door GN2/1 + GN1/1	1,700 / 2,094	1,600	24,561	18,629

Ask us about our plan stone and granite tops.

“ÉLÉGANCE” REFRIGERATED DISPLAY CABINETS ON OPEN CUPBOARD WITH 3 LEVELS, VENTILATED COOLING AND REAR AIRFLOW SYSTEM

Enodis
ADULT



on open cupboard



tank depth 30 to 110 mm

DESCRIPTION

AISI 304 stainless steel structure. AISI 304 stainless steel top thickness 2 mm. Rounded front edge. Laminate façade with 15 mm elevation. Includes 3-bar stainless steel handrail. Ventilated tank, base in 2 depth-adjustable parts (30 to 110 mm), GN1/1 compatible (oscillating ventilated evaporator) Noise level with refrigeration unit 56 dB(A). Comes with removable frame. Refrigerant R455A. Potentiometer for fan control to optimise operation and energy consumption. HCFO foam insulation. Adjustable control for the display cabinet. Touch-key controls.

Rounded refrigerated display cabinet with rear ventilation. Customer side open with thermal curtain. Curved glass cover on hydraulic cylinders for easy lifting and cleaning available as add-on. 2 sliding doors in double-walled Plexiglas with micro-perforations to allow laminar airflow with front suction to form the air curtain. 3 height-adjustable shelves. LED lighting. Operating temperature: 2°C/10°C. Condensate drip tray system included. 240 v single-phase power supply. Adult unit height overall dimensions: 1,700 mm Available without refrigeration unit (comes with vacuum pump, control facility, pressure regulator and evaporator), ex.

*Add SG to item number. Condensate drip tray not included.

“Élégance” refrigerated display cabinets on open cupboard with 3 levels, depth 30 to 110 mm

Item no.	Tank	Cooling capacity (w)	Length	With refrigeration unit Price in € (plus VAT)
	Tray capacity			Stainless steel top
VO3AL09ES	2 GN1/1	800 / 972	950	16,485
VO3AL12ES	3 GN1/1	900 / 1,166	1,250	17,154
VO3AL16ES	4 GN1/1	1,200 / 1,573	1,600	19,406
VO3AL20ES	5 GN1/1	1,400 / 1,717	2,000	21,362

Without refrigeration unit* Price in € (plus VAT)
Stainless steel top
15,182
15,809
16,577
17,897

Ask us about our plan stone and granite tops.

“ÉLÉGANCE” REFRIGERATED DISPLAY CABINETS WITH 3 LEVELS, VENTILATED COOLING, REAR AIRFLOW SYSTEM AND REFRIGERATED STORAGE

Enodis
ADULT

Easy'
Serve

COLD UNITS



with storage (1 door)



tank depth 30 to 110 mm

DESCRIPTION

AISI 304 stainless steel structure. AISI 304 stainless steel top thickness 2 mm. Rounded front edge. Laminate façade with 15 mm elevation. Includes 3-bar stainless steel handrail. Ventilated tank, base in 2 depth-adjustable parts (30 to 110 mm), GN1/1 compatible (oscillating ventilated evaporator) Noise level with refrigeration unit 56 dB(A). Comes with removable frame. Refrigerant R455A. Potentiometer for fan control to optimise operation and energy consumption. Dual adjustable control (display cabinet and storage area). Touch-key controls. HCFO foam insulation. Rounded refrigerated display cabinet with rear ventilation. Customer side open with thermal curtain. Curved glass cover on hydraulic cylinders for easy lifting and cleaning available as add-on. 2 sliding doors in double-walled Plexiglas with micro-perforations to allow laminar airflow with front suction to form the air curtain. 3 height-adjustable shelves. LED lighting.

Operating temperature: 2°C/10°C. Condensate drip tray system included.

Lower refrigerated storage area with 2 grids with 3 levels each for GN1/1 or 2/1 trays spaced 70 mm apart (GN trays not included). Stainless steel door(s) with removable lip seal.

Adult unit height overall dimensions: 1,700 mm.

240 v single-phase power supply.

Available without refrigeration unit (comes with vacuum pump, control facility, pressure regulator and evaporator), ex.

*Add SG to item number. Condensate drip tray not included.

“Élégance” refrigerated display cabinets with 3 levels, ventilated cooling, rear airflow system and refrigerated storage - depth 30 to 110 mm

Item no.	Tank Tray capacity	Refrigerated storage	Cooling capacity (w)	Length	With refrigeration unit	Without refrigeration unit*
					Price in € (plus VAT)	Price in € (plus VAT)
					Stainless steel top	Stainless steel top
VO3AR14ES	3 GN 1/1	1 x GN1/1 door	1,200 / 1,543	1,400	20,361	17,498
VO3AR16ES	4 GN 1/1	1 x GN2/1 door	1,500 / 19,50	1,600	22,262	18,165
VO3AR20ES	5 x GN 1/1	1 door GN2/1 + GN1/1	1,700 / 2,094	2,000	25,233	19,316

Ask us about our plan stone and granite tops.

“CLASSIQUE” REFRIGERATED DISPLAY CABINETS ON OPEN CUPBOARD WITH STATIC COOLING

Enodis
ADULT



on open cupboard



container depth 30 mm

DESCRIPTION

AISI 304 stainless steel structure. AISI 304 stainless steel top thickness 2 mm. Rounded front edge. Laminate façade with 15 mm elevation. Includes 3-bar stainless steel handrail. Recessed tank, depth 30 mm. Static refrigeration using copper coiling located under the tank with HCFO foam insulation. Noise level with refrigeration unit 56 dB(A). Comes with removable frame. Refrigerant R455A Dual adjustable control (display cabinet and tank). Touch-key controls. Glass display cabinet has insulated box and ventilated evaporator. Front-flow refrigeration and rear air return. Tempered glass sliding doors on service side and roller blind for fridge on customer side. Tempered double glazing on both sides. LED lighting on customer side. Condensate drip tray system included. 240 v single-phase power supply.

Adult unit height: 1,810 mm.

Available without refrigeration unit (comes with vacuum pump, control facility, pressure regulator and evaporator). *Add SG to item number. Condensate drip tray not included.

“Classique” refrigerated display cabinets - static tank - depth 30 mm on open cupboard - for starters or desserts

Item no.	Tank	Power (w)	Power (w)	Length	With refrigeration unit Price in € (plus VAT)
	Tray capacity	Electric	Cooling capacity (W)		Stainless steel top
VHOL12ES	3 GN1/1	1,200	1,543	1,200 / 1,250*	18,976
VHOL16ES	4 GN1/1	1,650	2,135	1,600	21,363
VHOL20ES	5 GN1/1	2,100	2,470	2,000	22,993
VHOL23ES	6 GN1/1	2,300	2,664	2,300	24,706

Without refrigeration unit* Price in € (plus VAT)
Stainless steel top
14,129
15,889
19,121
20,408

Ask us about our plan stone and granite tops.

“CLASSIQUE” REFRIGERATED DISPLAY CABINETS ON OPEN CUPBOARD WITH STATIC COOLING AND REFRIGERATED STORAGE

Enodis
ADULT

Easy'
Serve

COLD UNITS



with storage (1 door)



container depth 30 mm

DESCRIPTION

AISI 304 stainless steel structure. AISI 304 stainless steel top thickness 2 mm. Rounded front edge. Laminate façade with 15 mm elevation. Includes 3-bar stainless steel handrail. Recessed tank, depth 30 mm. Static refrigeration using copper coiling located under the tank with HCFO foam insulation. Noise level with refrigeration unit 56 dB(A). Comes with removable frame. Refrigerant R455A. Triple adjustable control (tank and storage area). Touch-key controls. Glass display cabinet has insulated box and ventilated evaporator. Front-flow refrigeration and rear air return. Tempered glass sliding doors on service side and roller blind for fridge on customer side. Tempered double glazing on both sides. LED lighting on customer side. Condensate drip tray system included.

Units with refrigerated storage: stainless steel door(s) with removable lip seal. With 5 grids for GN1/1 or GN2/1 trays (not included). 240 v single-phase power supply.

Adult unit height: 1,810 mm.

Available without refrigeration unit (comes with vacuum pump, control facility, pressure regulator and evaporator). *Add SG to item number. Condensate drip tray not included.

“Classique” refrigerated display cabinets - static tank - depth 30 mm with refrigerated storage - for starters or desserts

Item no.	Tank	Refrigerated storage	Power (w)	Power (w)	Length	With refrigeration unit	Without refrigeration unit*
	Tray capacity		Electric	Cooling capacity (W)		Price in € (plus VAT)	Price in € (plus VAT)
						Stainless steel top	Stainless steel top
VHOR14ES	3 GN 1/1	1 x GN1/1 door	1,200	1,543	1,400	21,448	16,675
VHOR16ES	4 GN 1/1	1 x GN2/1 door	1,700	2,135	1,600	23,911	18,589
VHOR20ES	5 x GN 1/1	1 x GN2/1 door	1,900	2,470	2,000	26,757	23,402
VHOR23ES	6 x GN 1/1	2 x GN2/1 doors	2,100	2,664	2,300	28,858	24,932

Ask us about our plan stone and granite tops.

“CLASSIQUE” REFRIGERATED DISPLAY CABINETS WITH STATIC COOLING ON OPEN CUPBOARD OR REFRIGERATED STORAGE

Enodis
ADULT



on open cupboard



container depth 110 mm

DESCRIPTION

AISI 304 stainless steel structure. AISI 304 stainless steel top thickness 2 mm. Rounded front edge. Laminate façade with 15 mm elevation. Includes 3-bar stainless steel handrail. Recessed tank, depth 110 mm. Static refrigeration using copper coiling located under the tank with HCFO foam insulation. Noise level with refrigeration unit 56 dB(A). Comes with removable frame. Refrigerant R455A. Dual adjustable control for open cupboard (display cabinet and drop-in well) and triple control for units with storage (display cabinet, tank and storage). Touch-key controls. Glass display cabinet has insulated box and ventilated evaporator. Front-flow refrigeration and rear air return. Tempered glass sliding doors on service side and roller blind for fridge on customer side. Tempered double glazing on both sides. LED lighting on customer side. Condensate drip tray system included. 240 v single-phase power supply.

Adult unit height: 1,810 mm.

Units with refrigerated storage: stainless steel door(s) with removable lip seal. With 5 grids for GN1/1 or GN2/1 trays (trays not included).

Available without refrigeration unit (comes with vacuum pump, control facility, pressure regulator and evaporator). *Add SG to item number. Condensate drip tray not included.

“Classique” refrigerated display cabinets - static tank - depth 110 mm on open cupboard - for drinks

Item no.	Tank	Power (w)	Power (w)	Length	With refrigeration unit
	Tray capacity	Electric	Cooling capacity (W)		Price in € (plus VAT)
VBOL12ES	3 GN1/1	1,200	1,543	1,200 / 1,250*	19,523
VBOL16ES	4 GN1/1	1,650	2,135	1,600	21,823
VBOL20ES	5 GN1/1	2,100	2,470	2,000	23,537
VBOL23ES	6 GN1/1	2,300	2,664	2,300	25,227

Without refrigeration unit*
Price in € (plus VAT)
Stainless steel top
14,565
16,283
19,665
20,929

Ask us about our plan stone and granite tops.

“CLASSIQUE” REFRIGERATED DISPLAY CABINETS WITH STATIC COOLING ON OPEN CUPBOARD OR REFRIGERATED STORAGE

Enodis
ADULT



with storage (1 door)

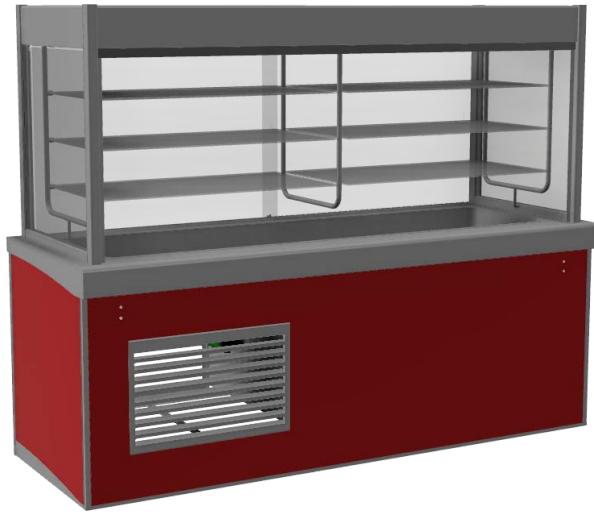

container depth 110 mm

DESCRIPTION

AISI 304 stainless steel structure. AISI 304 stainless steel top thickness 2 mm. Rounded front edge. Laminate façade with 15 mm elevation. Includes 3-bar stainless steel handrail. Recessed tank, depth 110 mm. Static refrigeration using copper coiling located under the tank with HCFO foam insulation. Noise level with refrigeration unit 56 dB(A). Comes with removable frame. Refrigerant R455A. Dual adjustable control for open cupboard (display cabinet and drop-in well) and triple control for units with storage (display cabinet, tank and storage). Touch-key controls. Glass display cabinet has insulated box and ventilated evaporator. Front-flow refrigeration and rear air return. Tempered glass sliding doors on service side and roller blind for fridge on customer side. Tempered double glazing on both sides. LED lighting on customer side. Condensate drip tray system included. 240 v single-phase power supply.

Adult unit height: 1,810 mm.

Units with refrigerated storage: stainless steel door(s) with removable lip seal. With 5 grids for GN1/1 or GN2/1 trays (trays not included).

Available without refrigeration unit (comes with vacuum pump, control facility, pressure regulator and evaporator). *Add SG to item number. Condensate drip tray not included.

“Classique” refrigerated display cabinets - static tank - depth 110 mm with refrigerated storage - for drinks

Item no.	Tank Tray capacity	Refrigerated storage	Power (w)		Length	With refrigeration unit	Without refrigeration unit*
			Electric	Cooling capacity (W)		Price in € (plus VAT)	Price in € (plus VAT)
						Stainless steel top	Stainless steel top
VBOR16ES	4 GN1/1	1 door GN2/1	1,700	2,135	1,600	24,354	21,246
VBOR20ES	5 GN1/1	1 door GN2/1	1,900	2,470	2,000	27,300	23,946
VBOR23ES	6 GN1/1	2 door GN2/1	2,100	2,664	2,300	29,254	25,453

Ask us about our plan stone and granite tops.

COLD UNITS - ADD-ONS

Enodis
ADULT



ADD-ONS FOR REFRIGERATED UNITS		
Item no.	Name	Price in € (plus VAT)
PVHP530	Additional charge for display counter height 530 mm	171
MVBE1	Deduction when purchased without drip trays for open cupboard drinks display unit, unit with 1-door & storage, or item number HO.	-211
MVBE2	Deduction when purchased without drip trays for drinks display unit with 2 doors and item number HO.	-421
MVBE3	Deduction when purchased without drip trays for open cupboard display cabinet on open cupboard	-437
MVBE4	Deduction when purchased without drip trays for display cabinet with refrigerated storage	-647
EMB10	Lower shelf for unit on open cupboard for unit length 950 mm	312
EMB12	Lower shelf for unit on open cupboard for unit length 1,200 mm	338
EMB13	Lower shelf for unit on open cupboard for unit length 1,350 mm	381
EMB16	Lower shelf for unit on open cupboard for unit length 1,600 mm	396
EMB20	Lower shelf for unit on open cupboard for unit length 2,000 mm	489
EMB23	Lower shelf for unit on open cupboard for unit length 2,300 mm	561
EMB26	Lower shelf for unit on open cupboard for unit length 2,600 mm	393
PVDV	Additional charge for vibrated top (per LM)	393
BPM	Mirror polished front edge (per LM)	162

RIGID NIGHT CURTAIN ADD-ONS WITH LOCK AND KEY FOR "CRISTALINE" DISPLAY CABINETS		
Item no.	Name	Price in € (plus VAT)
RDNFC2	"Cristaline" glass display units 2GN	1,556
RDNFC3	"Cristaline" glass display units 3GN	1,738
RDNFC4	"Cristaline" glass display units 4GN	1,958
RDNFC5	"Cristaline" glass display units 5GN	2,125
RDNFC6	"Cristaline" glass display units 6GN	2,371
RDNFC7	"Cristaline" glass display units 7GN	2,556
motorised		on request

COLD UNITS - ADD-ONS

Enodis
ADULT

**Easy'
Serve**

COLD UNITS

ADD-ONS FOR REFRIGERATED UNITS		
Item no.	Name	Price in € (plus VAT)
CEPO	Laminate end panel (per unit)	490
AGC	Air vent on customer side via opening in the laminate	870
RPP412I	Set of 4 stainless steel wheels diameter 125 mm (2 with brakes)	316
PCN220	16A power socket not protected/connected (per unit)	167
PCA	Arnoul socket (per unit)	338
PCTri	Tri-phase socket (per unit)	281
FCPORTREFRI	Lock with key for refrigerated door (one for each door)	105
TBCAV	Front control panel	393
TBCD	Right-side customer-facing control panel	393
TBCG	Left-side customer-facing control panel	393
ALH	Power supply via the top from a cabinet (maximum bar height 3,000 mm with mobile stainless steel plate to be fixed to the ceiling)	469
BIPR	Protective stainless steel strip (between counter top and tray slide) for reconstituted stone or granite top and rail (per LM)	170
HSPERPI	Special tray slide height (815 mm to 830 mm elevation) per unit	294
TDSB	Smoked Plexiglas plate shelf for salad'bar + fixings	356
BSC	Tank separator bar	62
GTROP	Tropicalised system	951
REGETF	Additional charge for EasyTouch controls on cold unit with USB socket and dynamic lighting	784

COLD UNITS - ADD-ONS

Enodis
ADULT



FRIDGE CURTAIN ADD-ONS (SERVICE SIDE) FOR CLASSIQUE DISPLAY CABINETS (INSTEAD OF SLIDING GLASS DOORS)		
Item no.	Name	Price in € (plus VAT)
RTVC3	"Classique" display cabinet 3GN1/1, 1,200 mm	401
RTVC4	"Classique" display cabinet 4GN1/1, 1,600 mm	498
RTVC5	"Classique" display cabinet 5GN1/1, 2,000 mm	585
RTVC6	"Classique" display cabinet 6GN1/1, 2300 mm	712

ADD-ONS FOR DISPLAY CABINETS		
Item no.	Name	Price in € (plus VAT)
AGSG	Replace glass shelves with guide rails	Please ask us





03

HEATED UNITS

Technical Information

- **All AISI 304 (18-10) stainless steel** construction .
- AISI 304 stainless steel **top thickness 2 mm** with 220 grain satin polish (**scotch-brite**).
Customer side counter surface profile 20 mm rounded edge with **110 mm drop**.
Service side counter surface straight edge with **60 mm drop**.
Available as add-on: granite or reconstituted stone top thickness 30 mm (one piece per unit). Granite or reconstituted stone top finished with straight edge on service side and end and rounded edge on customer side.
- Depth 830 mm, height 900 mm on stainless steel base height 180 mm adjustable -25/+50 mm.
- Units must be bolted at front and rear with sealant between **clean edge** panelling.
- Tray slide brackets in AISI 304 stainless steel fitted to frame through laminated front to ensure tray slide is fully aligned.
- **Standard stainless steel tray rail 3 profiled bars diameter 32 mm (included in unit price)**.
Available as add-on: granite rail, reconstituted stone rail, glass rail or laminate rail.
- Customer side **façade** as standard in **water-repellent melamine** coated in double-sided laminate **thickness 20 mm. 15 mm elevation** with lower stainless steel corner guard.
Available on request: 180 mm to 15 mm façade elevation with lower stainless steel corner guard.
Panels are fitted with an interlocking clip system and held in place by brackets.
Service side fascia panel attached with easily removable screws for access.
- **250 colours** to choose from our colour chart.
- Touch-key controls.
Available as add-on: Easy'Touch control panel.

Specifications

- **Ventilated air-heated tank with welded rounded corners** and self-adhesive 1.8 mm stainless steel armoured fin heaters on the underside of the tank with axial fans. Maximum tray depth 150 mm.
Temperature range 65°C to 105°C
- **Ventilated air-heated tank with welded rounded corners** and diamond pattern toward 3/4" drain plug. With self-adhesive 1.8 mm stainless steel armoured fin heaters on the underside of the tank. Maximum tray depth 150 mm. Temperature range 65°C to 85°C.
Tank fill automatically stops when full. 2 water level detection probes (min. and max. levels).
- **Top heated by black tempered glass-ceramic panels**, thickness 6 mm GN1/1 (505 x 325 mm). Temperature range 65°C to 105°C.
- **Ventilated chamber** with rock wool insulation. Temperature range 0°C to 85°C. Sliding doors with rock wool insulation. Power 230 V single-phase or 400 v 3-phase, Neutral and Earth.
- **Display counters**
Loose or with heating or lighting
High quality ceramic heating ramp, power 150 W/lamp with variothermal insulation.

Complies with AFNOR standard AC D 40-004 (the French industrial standards authority).

Our most

Enodis
ADULT
Easy'
Serve

POPULAR PRODUCTS

Hot air bain-marie

Rounded tank for GN1/1 trays depth 150 mm (available as add-on).

Hot air circulates the tank with stainless steel heating elements and axial fans.

Temperature control 65°C to 105°C.

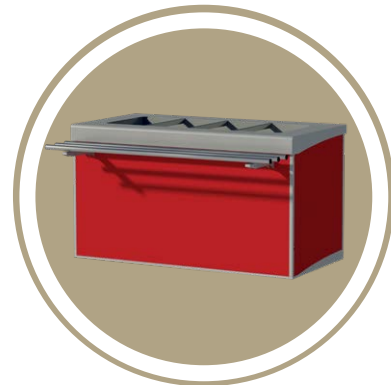

Water bain-marie

Rounded tank for GN1/1 trays depth 150 mm (available as add-on).

Tank fill automatically stops when full.

Underside heating using adhesive elements.

Temperature control 65°C to 85°C.

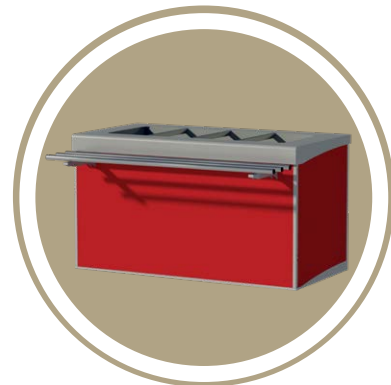

Vitrocho tempered glass top

Tempered glass rail thickness 6 mm GN1/1 (505 x 325 mm). Temperature range 65°C to 105°C.

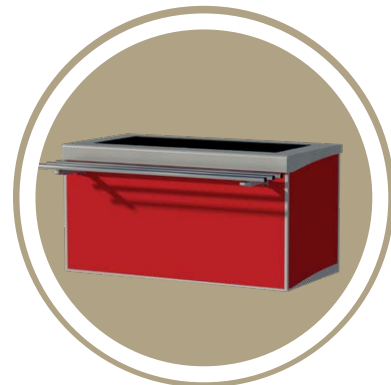

Stainless steel heated display top

AISI 304 stainless steel top thickness 3 mm.

Temperature range 65°C to 105°C.

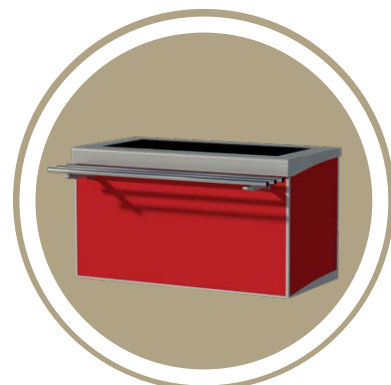

Our most

Endis
ADULT
Easy'
Serve

POPULAR PRODUCTS

Display counters

Polished stainless steel bar diameter 40 mm
Tempered glass shelf with curved sneeze guard
thickness 6 mm.
LED lighting and ceramic heating ramp (separate
controls) for models with heating/lighting.
Vertical pane for bain-marie display counters.

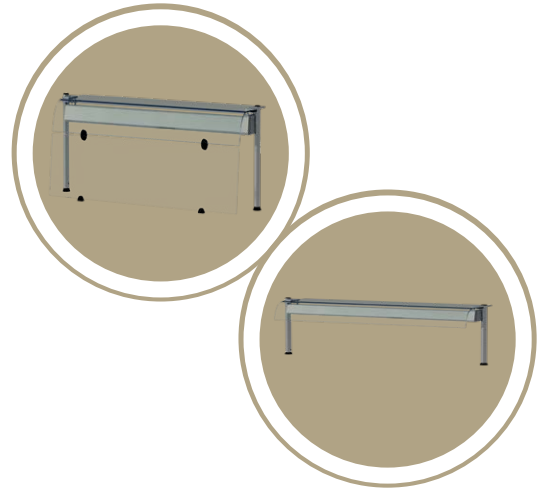

“Cristaline” hot glass display units

Rectangular heated display cabinet.
Temperature-holding surface made of GN1/1 black
tempered glass panels.
1 or 2 heated shelves (depending on model).
Stainless steel elements underneath.
Temperature control 65°C to 105°C.
LED lighting.
2 sliding Plexiglass doors.

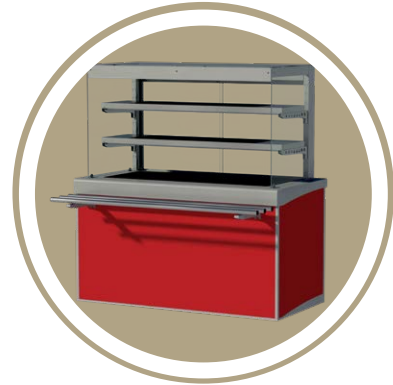

“Élégance” heated display cabinets

Round heated display cabinet.
Temperature-holding surface made of GN1/1 black
tempered glass panels.
1 or 2 heated shelves (depending on model).
Stainless steel elements underneath.
Temperature control 65°C to 105°C.
LED lighting.
2 sliding Plexiglass doors.

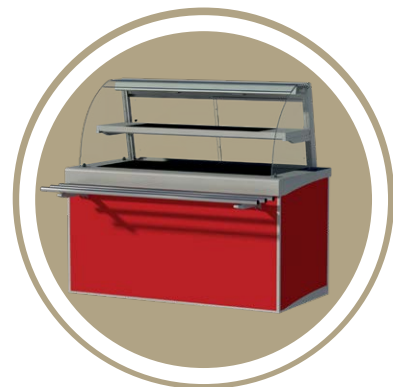

VENTILATED AIR BAIN-MARIE ON OPEN CUPBOARD

Enodis
ADULT



on open cupboard

DESCRIPTION

AISI 304 stainless steel structure. AISI 304 stainless steel top thickness 2 mm. Rounded front edge. Laminate façade with 15 mm elevation. Includes 3-bar stainless steel handrail. Radiant tank for GN1/1-150 trays (available as add-on). Heated by hot air circulating from stainless steel heating elements and axial fan. Touch-key controls. Power 400 v 3-phase.

Ventilated hot air bain-marie on open cupboard

Item no.	Tank Tray capacity	Power (w)	Power supply	Length	Price in € (plus VAT) Stainless steel top
BMVL2ES	2 GN1/1	1,550	230/50/1 + N	800	5,757
BMVL3ES	3 GN1/1	3,100	230/50/1 + N	1,200	7,041
BMVL4ES	4 GN1/1	4,650	400/50/3 + N	1,600	8,334
BMVL5ES	5 GN1/1	4,650	400/50/3 + N	2,000	9,185
BMVL6ES	6 GN1/1	6,200	400/50/3 + N	2,300	10,283

Ask us about our plan stone and granite tops.

VENTILATED AIR BAIN-MARIE WITH CHAMBER

Enodis
ADULT

Easy'
Serve

HEATED
UNITS



with radiant heat chamber

DESCRIPTION

AISI 304 stainless steel structure. AISI 304 stainless steel top thickness 2 mm. Rounded front edge. Laminate façade with 15 mm elevation. Includes 3-bar stainless steel handrail. Radiant tank for GN1/150 trays (available as add-on). Heated by hot air circulating from stainless steel heating elements and axial fan. Touch-key controls. Rear radiant heat chamber and sides (r= 10 mm) with fixed bottom radius. Sliding doors with rock wool insulation. The chamber is heated by ventilated armoured heating elements (0 to 85°C). Power 400 v 3-phase.

Ventilated hot air bain-marie with radiant heat chamber

Item no.	Tank	Power (w)	Power supply	Length	Price in € (plus VAT)
	Tray capacity				Stainless steel top
BMVE3ES	3 GN1/1	4,700	400/50/3 + N	1,200	8,316
BMVE4ES	4 GN1/1	7,750	400/50/3 + N	1,600	10,085
BMVE5ES	5 GN1/1	7,750	400/50/3 + N	2,000	11,159
BMVE6ES	6 GN1/1	9,300	400/50/3 + N	2300	12,549

Ask us about our plan stone and granite tops.

WATER BAIN-MARIE ON OPEN CUPBOARD

Enodis
ADULT

Easy'
Serve



on open cupboard

DESCRIPTION

AISI 304 stainless steel structure. AISI 304 stainless steel top thickness 2 mm. Rounded front edge. Laminate façade with 15 mm elevation. Includes 3-bar stainless steel handrail. Radiant tank for GN1/1-150 trays (available as add-on). Underside heating using adhesive elements. Touch-key controls. Power 240 v single-phase or 400 v 3-phase (depending on model).

Water bain-marie on open cupboard

Item no.	Tank Tray capacity	Power (w)	Power supply	Length	Price in € (plus VAT) Stainless steel top
BMHL2ES	2 GN1/1	1460	230/50/1 + N	800	5,742
BMHL3ES	3 GN1/1	2,190	400/50/3 + N**	1,200	6,216
BMHL4ES	4 GN1/1	2,920	400/50/3 + N**	1,600	7,041
BMHL5ES	5 GN1/1	3,650	400/50/3 + N	2,000	7,843
BMHL6ES	6 GN1/1	4,380	400/50/3 + N	2,300	8,559

Ask us about our plan stone and granite tops.

** Single-phase power available on request.

WATER BAIN-MARIES ON OPEN CUPBOARD & WITH REAR SHELF

Enodis
ADULT

Easy'
Serve



on open cupboard with rear shelf

DESCRIPTION

AISI 304 stainless steel structure. AISI 304 stainless steel top thickness 2 mm. Rounded front edge. Laminate façade with 15 mm elevation. Includes 3-bar stainless steel handrail. Radiant tank for GN1/1-150 trays (available as add-on). Underside heating using adhesive elements. Touch-key controls. Power 240 v single-phase or 400 v 3-phase (depending on model).

Water bain-maries on open cupboard & with rear loose shelf

Item no.	Tank Tray capacity	Power (w)	Power supply	Length	Price in € (plus VAT) Stainless steel top
BMHLT3ES	3 GN1/1	2,190	400/50/3 + N**	1,200	7,624
BMHLT4ES	4 GN1/1	2,920	400/50/3 + N	1,600	8,583
BMHLT5ES	5 GN1/1	3,650	400/50/3 + N	2,000	9,497
BMHLT6ES	6 GN1/1	4,380	400/50/3 + N	2,300	10,713

Ask us about our plan stone and granite tops.

** 240 v single-phase power or 400 v 3-phase available on request (depending on model).

WATER BAIN-MARIES WITH HEATED CHAMBER

Enodis
ADULT



with radiant heat chamber

DESCRIPTION

AISI 304 stainless steel structure. AISI 304 stainless steel top thickness 2 mm. Rounded front edge. Laminate façade with 15 mm elevation. Includes 3-bar stainless steel handrail. Radiant tank for GN1/150 trays (available as add-on). Underside heating using adhesive elements. Rear rounded heat chamber and sides (r= 10 mm) with fixed bottom radius. Sliding doors with rock wool insulation (note: 800 mm unit comes with swing door). The chamber is heated by ventilated armoured heating elements (0 to 85°C). Touch-key controls. Power 240 v single-phase or 400 v 3-phase (depending on model).

Water bain-maries with rounded heated chamber

Item no.	Tank	Power (w)	Power supply	Length	Price in € (plus VAT)
	Tray capacity				Stainless steel top
BMHE2ES	2 GN1/1	3,060	400/50/3 + N	800/950*	6,421
BMHE3ES	3 GN1/1	3,850	400/50/3 + N	1,200	7,311
BMHE4ES	4 GN1/1	5,100	400/50/3 + N	1,600	8,574
BMHE5ES	5 GN1/1	6,850	400/50/3 + N	2,000	9,616
BMHE6ES	6 GN1/1	7,600	400/50/3 + N	2,300	10,598

Ask us about our plan stone and granite tops.

WATER BAIN-MARIES ON OPEN CUPBOARD & WITH REAR SHELF

Enodis
ADULT



with radiant heat chamber and rear shelf

DESCRIPTION

AISI 304 stainless steel structure. AISI 304 stainless steel top thickness 2 mm. Rounded front edge. Laminate façade with 15 mm elevation. Includes 3-bar stainless steel handrail. Radiant tank for GN1/150 trays (available as add-on). Underside heating using adhesive elements. Rear rounded heat chamber and sides (r= 10 mm) with fixed bottom radius. Sliding doors with rock wool insulation. The chamber is heated by ventilated armoured heating elements (0 to 85°C). Touch-key controls. Power 240 v single-phase or 400 v 3-phase (depending on model).

Water bain-maries on open cupboard with rounded heat chamber & rear shelf

Item no.	Tank Tray capacity	Power (w)	Power supply	Length	Price in € (plus VAT)
					Stainless steel top
BMHET3ES	3 GN1/1	3,850	400/50/3 + N	1,200/1,500*	8,245
BMHET4ES	4 GN1/1	5,100	400/50/3 + N	1,600	9,490
BMHET5ES	5 GN1/1	6,850	400/50/3 + N	2,000	11,374
BMHET6ES	6 GN1/1	7,600	400/50/3 + N	2,300	12,267

Ask us about our plan stone and granite tops.

“VITROCHO” HEATED TOP UNIT - ON OPEN CUPBOARD

Enodis
ADULT

**Easy'
Serve**



on open cupboard

DESCRIPTION

AISI 304 stainless steel structure. AISI 304 stainless steel top thickness 2 mm. Rounded front edge. Laminate façade with 15 mm elevation. Includes 3-bar stainless steel handrail. Temperature-holding surface made of black tempered glass panels thickness 6 mm. Ultra temperature uniformity at 90°C. Touch-key controls. Power 240 v single-phase or 400 v 3-phase (depending on model).

“Vitrocho” units on open cupboard

Item no.	Tank Tray capacity	Power (w)	Power supply	Length	Price in € (plus VAT) Stainless steel top
MVL2ES	2 GN1/1	900	230/50/1 + N	800/950*	4,967
MVL3ES	3 GN1/1	1,350	400/50/3 + N	1,200	5,967
MVL4ES	4 GN1/1	1,800	400/50/3 + N	1,600	6,846
MVL5ES	5 GN1/1	2,250	400/50/3 + N	2,000	7,736
MVL6ES	6 GN1/1	2,700	400/50/3 + N	2,300	8,488

Ask us about our plan stone and granite tops.

“VITROCHO” HEATED TOP UNIT - WITH CHAMBER

Enodis
ADULT

Easy'
Serve

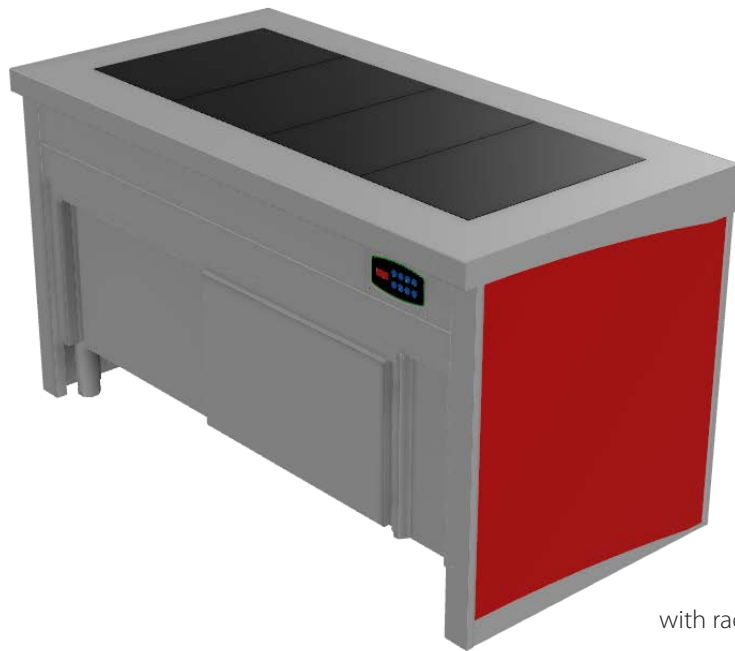

with radiant heat chamber

DESCRIPTION

AISI 304 stainless steel structure. AISI 304 stainless steel top thickness 2 mm. Rounded front edge. Laminate façade with 15 mm elevation. Includes 3-bar stainless steel handrail. Temperature-holding surface made of black tempered glass panels thickness 6 mm. Ultra temperature uniformity at 90°C. Touch-key controls. Rear radiant heat chamber and sides (r= 10 mm) with fixed bottom radius. Sliding doors with rock wool insulation (note: 800 mm unit comes with swing door). The chamber is heated by ventilated armoured heating elements (0 to 85°C). Power 400 v 3-phase.

“Vitrocho” units with rounded heat chamber

Item no.	Tank Tray capacity	Power (w)	Power supply	Length	Price in € (plus VAT)
					Stainless steel top
MVE2ES	2 GN1/1	2,500	400/50/3 + N	800/950*	5,698
MVE3ES	3 GN1/1	2,950	400/50/3 + N	1,200	6,368
MVE4ES	4 GN1/1	4,900	400/50/3 + N	1,600	7,766
MVE5ES	5 GN1/1	5,350	400/50/3 + N	2,000	9,169
MVE6ES	6 GN1/1	5,800	400/50/3 + N	2,300	10,426

Ask us about our plan stone and granite tops.

“VITROCHO” HEATED TOP UNIT - WITH REAR SHELF CHAMBER

Enodis
ADULT

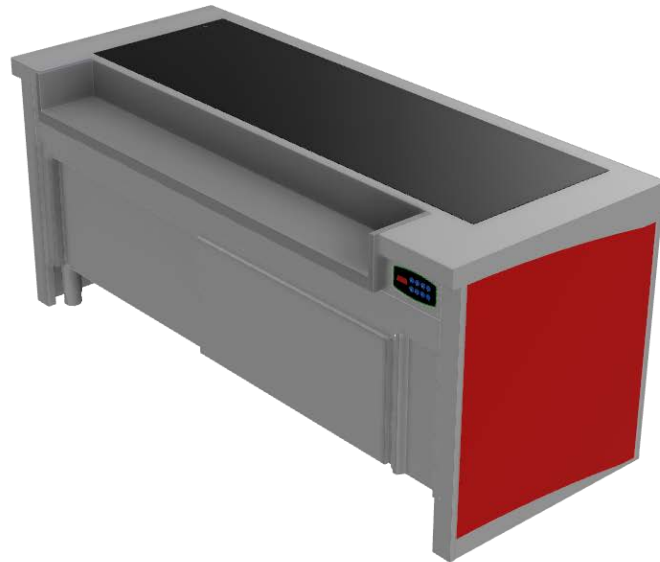

with radiant chamber and rear shelf

DESCRIPTION

AISI 304 stainless steel structure. AISI 304 stainless steel top thickness 2 mm. Rounded front edge. Laminate façade with 15 mm elevation. Includes 3-bar stainless steel handrail. Temperature-holding surface made of black tempered glass panels thickness 6 mm. Ultra temperature uniformity at 90°C. Touch-key controls. Rear radiant heat chamber and sides (r= 10 mm) with fixed bottom radius. Sliding doors with rock wool insulation. The chamber is heated by ventilated armoured heating elements (0 to 85°C).
Power 400 v 3-phase.

“Vitrocho” units with radiant heat chamber and rear shelf

Item no.	Tank	Power (w)	Power supply	Length	Price in € (plus VAT)
	Tray capacity				Stainless steel top
MVET3ES	3 GN1/1	2,950	400/50/3 + N	1,200/1,250*	7,398
MVET4ES	4 GN1/1	4,900	400/50/3 + N	1,600	8,851
MVET5ES	5 GN1/1	5,350	400/50/3 + N	2,000	10,306
MVET6ES	6 GN1/1	5,800	400/50/3 + N	2,300	11,625

Ask us about our plan stone and granite tops.

STAINLESS STEEL HEATED TOP UNIT - Enodis WITH CHAMBER ADULT

**Easy'
Serve**

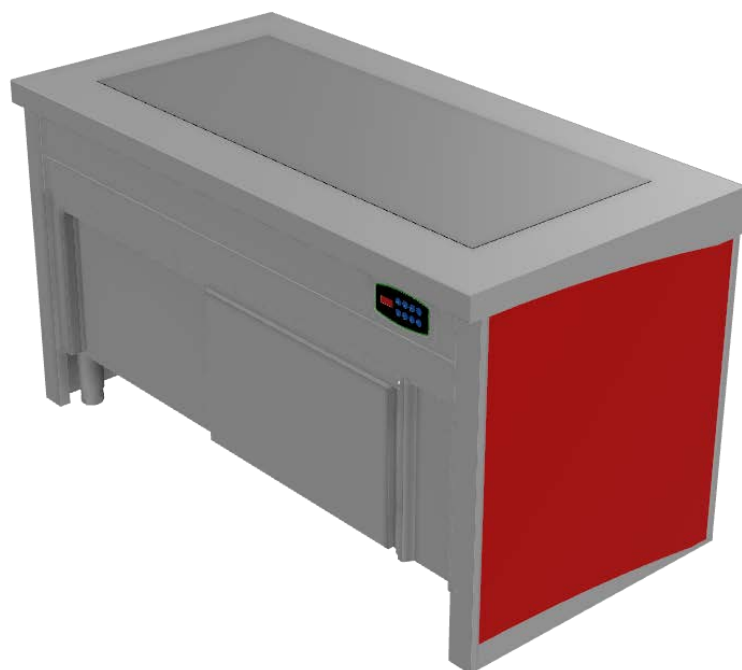

with radiant heat chamber

DESCRIPTION

AISI 304 stainless steel structure. AISI 304 stainless steel top thickness 2 mm. Rounded front edge. Laminate façade with 15 mm elevation. Includes 3-bar stainless steel handrail. Temperature-holding surface made of stainless steel panel thickness 4 mm. Touch-key controls. Rear radiant heat chamber and sides (r= 10 mm) with fixed bottom radius. Sliding doors with rock wool insulation (note: 800 mm unit comes with swing door). The chamber is heated by ventilated armoured heating elements (0 to 85°C). Power 400 v 3-phase. Unit not available with granite top.

Stainless steel heated top units

Item no.	Power (w)	Power supply	Length	Price in € (plus VAT) Stainless steel top
MCA080ES	2,500	400/50/3 + N	800	5,112
MCA120ES	2,950	400/50/3 + N	1,200	5,363
MCA160ES	4,900	400/50/3 + N	1,600	6,265
MCA200ES	5,350	400/50/3 + N	2,000	7,611
MCA230ES	5,800	400/50/3 + N	2,300	8,644

GLASS DISPLAY COUNTERS 1 LEVEL

Enodis
ADULT

Easy'
Serve

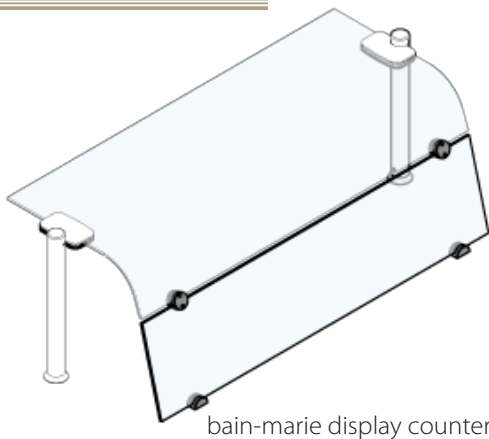

bain-marie display counter



vitrocho display counter

DESCRIPTION

Bain-marie display counter with tempered curved glass 6mm. Polished stainless steel bars diameter 40mm.
Height 385 mm. Vertical guard in white tempered glass 6 mm.
Available as add-on: ceramic heating ramp + LED lighting under single shelf. LED lighting. 240 v single-phase power supply. Vibrated and polished.

Bain-marie display counters

Single shelf			Single shelf + LED lighting + heating		
Tank	Item no.	Price in € (plus VAT)	Item no.	Power (w) LED lighting + heating	Price in € (plus VAT)
2 GN1/1	TDSB08	739	TDSB08CLED	8 + 150	1,564
3 GN1/1	TDSB12	776	TDSB12CLED	14 + 300	1,638
4 GN1/1	TDSB16	886	TDSB16CLED	20 + 300	1,844
5 GN1/1	TDSB20	1,034	TDSB20CLED	26 + 450	2,318
6 GN1/1	TDSB23	1,179	TDSB23CLED	30 + 450	2,748

DESCRIPTION

Vitrocho display counter: single tempered curved glass shelf 6 mm. Polished stainless steel bar diameter 40 mm.
Height 385 mm.
Available as add-on: ceramic heating ramp + LED lighting under single shelf. LED lighting. 240 v single-phase power supply. Vibrated and polished.

Vitrocho surface display counters

Single shelf			Single shelf + LED lighting + heating		
Tank	Item no.	Price in € (plus VAT)	Item no.	Power (w) LED lighting + heating	Price in € (plus VAT)
2 GN1/1	TDSV08	696	TDSV08CLED	8 + 150	1,522
3 GN1/1	TDSV12	733	TDSV12CLED	14 + 300	1,612
4 GN1/1	TDSV16	772	TDSV16CLED	20 + 300	1,905
5 GN1/1	TDSV20	1,070	TDSV20CLED	26 + 450	2,243
6 GN1/1	TDSV23	1,093	TDSV23CLED	30 + 450	2,604

DISPLAY COUNTER ADD-ONS

Item no.	Name	Price in € (plus VAT)
PVHP530	Additional charge for display counter height 530 mm	171

GLASS DISPLAY COUNTERS WITH STAINLESS STEEL TOP 1 LEVEL

Enodis
ADULT

Easy'
Serve

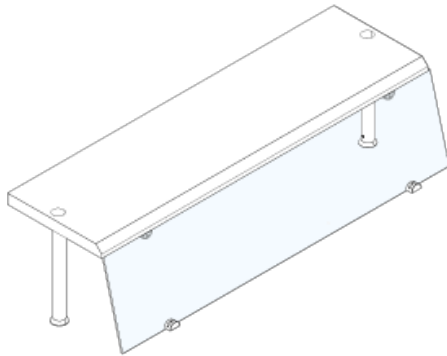

display counter 1 level

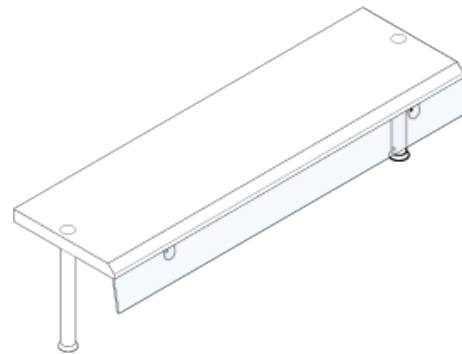

display counter 1 level

DESCRIPTION

1.8 mm stainless steel display counters with straight glass sneeze guard in 6 mm white tempered glass. Polished stainless steel bars diameter 40 mm. Height 370 mm with 1 level and 640 mm with 2. 240 v single-phase power supply. Available as add-on: one or two under-shelf LED lighting strips for first and/or second shelf.

Stainless steel display counters with front-closing sneeze guard - 1 level

Length	GN capacity	Single shelf		Single shelf (for each shelf) + LED lighting		
		Item no.	Price in € (plus VAT)	Item no.	LED lighting wattage (per shelf)	Price in € (plus VAT)
800	2	TDSB08-I	1,170	TDSB08LED-I	8	1,855
1,200	3	TDSB12-I	1,270	TDSB12LED-I	14	2,040
1,600	4	TDSB16-I	1,372	TDSB16LED-I	20	2,075
2,000	5	TDSB20-I	1,749	TDSB20LED-I	26	2,865
2,300	6	TDSB23-I	1,955	TDSB23LED-I	30	3,390

Stainless steel & glass display counters - 1 level

Length	GN capacity	Single shelf		Single shelf (for each shelf) + LED lighting		
		Item no.	Price in € (plus VAT)	Item no.	LED lighting wattage (per shelf)	Price in € (plus VAT)
800	2	TDSV08-I	1,053	TDSV08LED-I	8	1,742
1,200	3	TDSV12-I	1,170	TDSV12LED-I	14	1,942
1,600	4	TDSV16-I	1,285	TDSV16LED-I	20	2,188
2,000	5	TDSV20-I	1,634	TDSV20LED-I	26	2,800
2,300	6	TDSV23-I	1,793	TDSV23LED-I	30	3,240

2 LEVEL GLASS DISPLAY COUNTERS WITH SNEEZE GUARD

Enodis
ADULT



display counter 2 levels

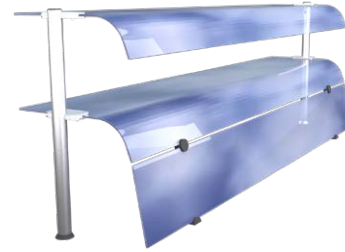

display counter 2 levels

DESCRIPTION

1.8 mm stainless steel display counters with straight glass sneeze guard in 6 mm white tempered glass. Polished stainless steel bars diameter 40 mm. Height 370 mm with 1 level and 640 mm with 2. 240 v single-phase power supply. Available as add-on: one or two under-shelf LED lighting strips for first and/or second shelf.

Glass display counters with sneeze guard - 2 levels

Length	GN capacity	Lighting wattage	Double shelf		Double shelves + LED lighting 1 level		Double shelves + LED lighting 2 levels		
			LED	Item no.	Price in € (plus VAT)	Item no.	Price in € (plus VAT)	Item no.	Price in € (plus VAT)
800	2	8		PICD08	1,129	PICD08LED1	1,560	PICD08LED2	1,991
1,200	3	14		PICD12	1,266	PICD12LED1	1,832	PICD12LED2	2,398
1,600	4	20		PICD16	1,397	PICD16LED1	2,090	PICD16LED2	2,783
2,000	5	26		PICD20	1,781	PICD20LED1	2,640	PICD20LED2	3,499
2,300	6	30		PICD23	1,998	PICD23LED1	3,015	PICD23LED2	4,032

Glass display counters with sneeze guard - 2 front-closing levels

Length	GN capacity	Lighting wattage	Double shelf		Double shelves + LED lighting 1 level		Double shelves + LED lighting 2 levels		
			LED	Item no.	Price in € (plus VAT)	Item no.	Price in € (plus VAT)	Item no.	Price in € (plus VAT)
800	2	8		PICDFD08	1,198	PICDFD08LED1	1,629	PICDFD08LED2	2,062
1,200	3	14		PICDFD12	1,339	PICDFD12LED1	1,905	PICDFD12LED2	2,471
1,600	4	20		PICDFD16	1,484	PICDFD16LED1	2,177	PICDFD16LED2	2,870
2,000	5	26		PICDFD20	1,946	PICDFD20LED1	2,805	PICDFD20LED2	3,664
2,300	6	30		PICDFD23	2,131	PICDFD23LED1	3,148	PICDFD23LED2	4,165

*Per shelf

2 LEVEL DISPLAY COUNTERS IN STAINLESS STEEL WITH SNEEZE GUARD

Enodis
ADULT

Easy'
Serve

HEATED
UNITS

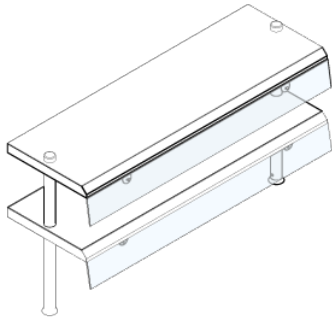

display counter 2 levels

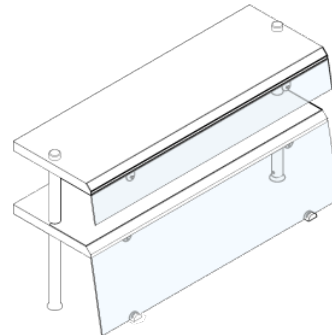

display counter 2 levels

DESCRIPTION

1.8 mm stainless steel display counters with straight glass sneeze guard in 6 mm white tempered glass. Polished stainless steel bars diameter 40 mm. Height 370 mm with 1 level and 640 mm with 2. 240 v single-phase power supply. Available as add-on: one or two under-shelf LED lighting strips for first and/or second shelf.

Stainless steel display counters with sneeze guard - 2 levels

Length	GN capacity	Lighting wattage LED	Double shelf		Double shelves + LED lighting 1 level		Double shelves + LED lighting 2 levels	
			Item no.	Price in € (plus VAT)	Item no.	Price in € (plus VAT)	Item no.	Price in € (plus VAT)
800	2	8	PIDD08-I	1,534	PIDD08LED1-I	1,965	PIDD08LED2-I	2,395
1,200	3	14	PIDD12-I	1,698	PIDD12LED1-I	2,264	PIDD12LED2-I	2,830
1,600	4	20	PIDD16-I	1,865	PIDD16LED1-I	2,558	PIDD16LED2-I	3,251
2,000	5	26	PIDD20-I	2,368	PIDD20LED1-I	3,227	PIDD20LED2-I	4,085
2,300	6	30	PIDD23-I	2,674	PIDD23LED1-I	3,691	PIDD23LED2-I	4,707

Stainless steel display counters with sneeze guard - 2 front-closing levels

Length	GN capacity	Lighting wattage LED	Double shelf		Double shelves + LED lighting 1 level		Double shelves + LED lighting 2 levels	
			Item no.	Price in € (plus VAT)	Item no.	Price in € (plus VAT)	Item no.	Price in € (plus VAT)
800	2	8	TDFD08-I	1,592	TDFD08LED1-I	2,023	TDFD08LED2-I	2,454
1,200	3	14	TDFD12-I	1,771	TDFD12LED1-I	2,337	TDFD12LED2-I	2,903
1,600	4	20	TDFD16-I	1,937	TDFD16LED1-I	2,629	TDFD16LED2-I	3,322
2,000	5	26	TDFD20-I	2,554	TDFD20LED1-I	3,412	TDFD20LED2-I	4,270
2,300	6	30	TDFD23-I	2,802	TDFD23LED1-I	3,619	TDFD23LED2-I	4,836

*Per shelf

VITROCHO FOOD COUNTER

Enodis
ADULT

Easy'
Serve

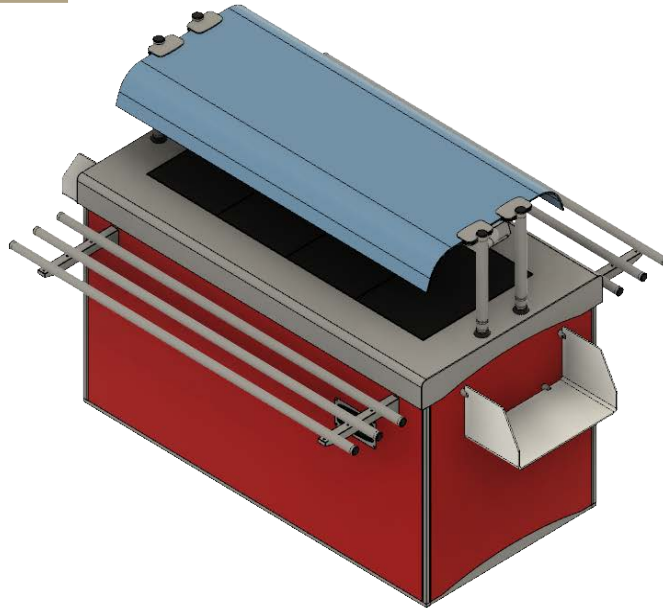

DESCRIPTION

AISI 304 stainless steel structure. AISI 304 stainless steel top thickness 2 mm. Rounded front edge. Laminate façade with 15 mm elevation. Includes 2 3-bar stainless steel handrails. Temperature-holding surface made of GN1/1 black tempered glass panels. Touch-key controls. Display counter with curved glass on both sides (6 mm) plus LED lighting and heating ramp as standard. 2 stainless steel sections on each side diameter 40 mm. Side shelves included. Closed cabinet body. Width: 1470 mm with both handrails, height: 900 mm. Power 400 v 3-phase.

Vitrocho food counter - no recess

Item no.	Tray	Power (w)	Power supply	Length	Price in € (plus VAT)
	Tray capacity				Stainless steel top
SBR-MVL4ES-SD	4 GN1/1	1,750	400/50/3 + N	1,600	12,893
SBR-MVL5ES-SD	5 GN1/1	2,150	400/50/3 + N	2,000	14,112
SBR-MVL6ES-SD	6 GN1/1	2,600	400/50/3 + N	2,300	16,124

Ask us about our plan stone and granite tops.

Vitrocho food counter - 60 mm recess

Item no.	Tray	Power (w)	Power supply	Length	Price in € (plus VAT)
	Tray capacity				Stainless steel top
SBR-MVL4ES-60	4 GN1/1	1,750	400/50/3 + N	1,600	13,710
SBR-MVL5ES-60	5 GN1/1	2,150	400/50/3 + N	2,000	14,928
SBR-MVL6ES-60	6 GN1/1	2,600	400/50/3 + N	2,300	16,940

Ask us about our plan stone and granite tops.

Vitrocho food counter - 110 mm recess

Item no.	Tray	Power (w)	Power supply	Length	Price in € (plus VAT)
	Tray capacity				Stainless steel top
SBR-MVL4ES-110	4 GN1/1	1,750	400/50/3 + N	1,600	14,240
SBR-MVL5ES-110	5 GN1/1	2,150	400/50/3 + N	2,000	15,459
SBR-MVL6ES-110	6 GN1/1	2,600	400/50/3 + N	2,300	17,471

Ask us about our plan stone and granite tops.

HOT AIR FOOD COUNTER

Enodis
ADULT

Easy'
Serve

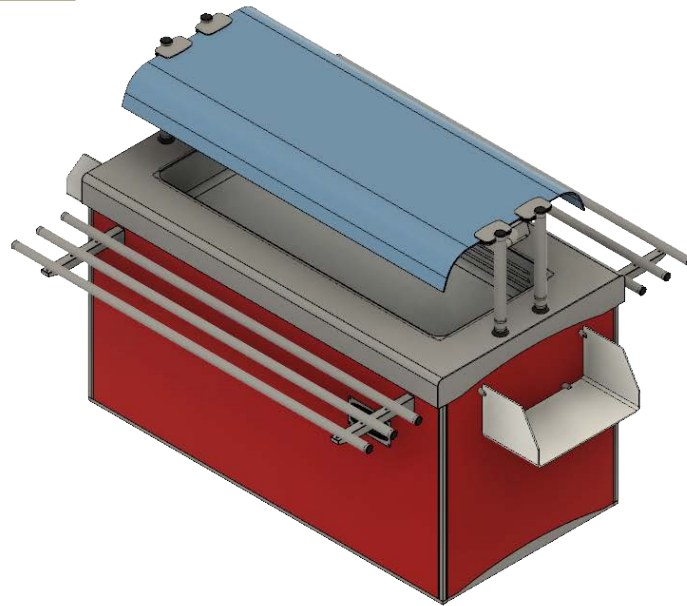

DESCRIPTION

AISI 304 stainless steel structure. AISI 304 stainless steel top thickness 2 mm. Rounded front edge. Laminate façade with 15 mm elevation. Includes 2 3-bar stainless steel handrails. Tank depth 180 mm; for GN1/1 trays depth 150 mm (available as add-on). Hot air circulates the tank with stainless steel heating elements and axial fans. Touch-key controls. Display counter with curved glass on both sides (6 mm) plus LED lighting and heating ramp as standard. 2 stainless steel sections on each side diameter 40 mm. Side shelves included. Closed cabinet body. Width: 1470 mm with both handrails, height: 900 mm. 3-phase power supply (single-phase available on request).

Hot air bain-marie food counter - tank depth 180 mm

Item no.	Tank	Power (w)	Power supply	Length	Price in € (plus VAT)
	Tray capacity	Electric			Stainless steel top
SBR-BMVL3ES	3 GN1/1	3,200	230/50/1 + N	1,200	12,403
SBR-BMVL4ES	4 GN1/1	4,650	400/50/3 + N	1,600	13,773
SBR-BMVL5ES	5 GN1/1	4,650	400/50/3 + N	2,000	15,324
SBR-BMVL6ES	6 GN1/1	6,200	400/50/3 + N	2,300	17,169

Ask us about our plan stone and granite tops.

Deduction when purchased without heating ramp (BM display counter with 2 curved sides and lighting)

Item no.	Tank	Length	Price in € (plus VAT)
	Tray capacity		
MVRC1600	4 GN1/1	1,600	264
MVRC2000	5 GN1/1	2,000	330
MVRC2300	6 GN1/1	2,300	506

Deduction when purchased without Plexiglass plate shelf

Item no.	Price in € (plus VAT)
MVTDAP	290

“CRISTALINE” HEATED DISPLAY CABINETS, 1 LEVEL ON OPEN CUPBOARD OR WITH HEATED CHAMBER

Enodis
ADULT



DESCRIPTION

AISI 304 stainless steel structure. AISI 304 stainless steel top thickness 2 mm. Rounded front edge. Laminate exterior. 15 mm elevation. Includes 3 stainless steel handrails. Rectangular heated display cabinet. Temperature-holding surface and shelf made of GN1/1 black tempered glass panels heated underneath by adhesive elements. Ultra temperature uniformity at 90°C. Open on customer side. Straight glass cover on hydraulic cylinders for easy lifting and cleaning available as add-on. Power 400 v 3-phase. 2 sliding Plexiglass doors. LED lighting. Touch-key controls.

Adult unit height overall dimensions: 1,510 mm

“Cristaline” heated display cabinets, on open cupboard or with heated chamber - 1 level

Trays Tray capacity	Unit on open cupboard				Unit with heated chamber			
	Item no.	Power (w)	Length	Price in € (plus VAT) Stainless steel top	Item no.	Power (w)	Length	Price in € (plus VAT) Stainless steel top
2 GN1/1	VCO1CL09ES	1,490	950	13,274	VCO1CE09ES	3,090	950	15,641
3 GN1/1	VCO1CL12ES	2,350	1,250	14,383	VCO1CE12ES	3,950	1,250	16,975
4 GN1/1	VCO1CL16ES	2,780	1,600	16,140	VCO1CE16ES	4,380	1,600	19,004
5 GN1/1	VCO1CL20ES	3,740	2,000	18,078	VCO1CE20ES	5,340	2,000	21,237
6 GN1/1	VCO1CL23ES	4,700	2,300	22,983	VCO1CE23ES	6,300	2,300	25,223
7 GN1/1	VCO1CL26ES	5,330	2,600	26,513	VCO1CE26ES	8,530	2,600	31,660

Ask us about our plan stone and granite tops.

“CRISTALINE” HEATED DISPLAY CABINETS, 2 LEVELS ON OPEN CUPBOARD OR WITH HEATED CHAMBER

Enodis
ADULT

Easy'
Serve

HEATED
UNITS



DESCRIPTION

AISI 304 stainless steel structure. AISI 304 stainless steel top thickness 2 mm. Rounded front edge. Laminate exterior. 15 mm elevation. Includes 3 stainless steel handrails. Rectangular heated display cabinet. Temperature-holding surface and 2 shelves made of GN1/1 black tempered glass panels heated underneath by adhesive elements. Ultra temperature uniformity at 90°C. Open on customer side. Straight glass cover on hydraulic cylinders for easy lifting and cleaning available as add-on. Power 400 v 3-phase. 2 sliding Plexiglass doors. LED lighting. Touch-key controls.

Adult unit height overall dimensions: 1,710 mm

“Cristaline” heated display cabinets, on open cupboard or with heated chamber - 2 levels

Trays		Unit on open cupboard			Unit with heated chamber			
Tray capacity	Item no.	Power (w)	Length	Price in € (plus VAT) Stainless steel top	Item no.	Power (w)	Length	Price in € (plus VAT) Stainless steel top
2 GN1/1	VCO2CL09ES	2,020	950	15,573	VCO2CE09ES	3,620	950	17,941
3 GN1/1	VCO2CL12ES	3,310	1,250	17,175	VCO2CE12ES	4,910	1,250	19,766
4 GN1/1	VCO2CL16ES	3,740	1,600	19,349	VCO2CE16ES	5,340	1,600	22,216
5 GN1/1	VCO2CL20ES	5,180	2,000	21,685	VCO2CE20ES	8,380	2,000	24,844
6 GN1/1	VCO2CL23ES	6,620	2,300	25,413	VCO2CE23ES	9,820	2,300	27,910
7 GN1/1	VCO2CL26ES	7,250	2,600	28,402	VCO2CE26ES	10450	2600	33,554

Ask us about our plan stone and granite tops.

“CRISTALINE” HEATED DISPLAY CABINETS, 3 LEVELS ON OPEN CUPBOARD OR WITH HEATED CHAMBER

Enodis
ADULT



DESCRIPTION

AISI 304 stainless steel structure. AISI 304 stainless steel top thickness 2 mm. Rounded front edge. Laminate exterior. 15 mm elevation. Includes 3 stainless steel handrails. Rectangular heated display cabinet. Temperature-holding surface and 2 shelves made of GN1/1 black tempered glass panels heated underneath by adhesive elements. Ultra temperature uniformity at 90°C. Open on customer side. Straight glass cover on hydraulic cylinders for easy lifting and cleaning available as add-on. Power Tri400 v. 2 sliding Plexiglass doors. LED lighting. Touch-key controls.

Adult unit height overall dimensions: 1,910 mm

“Cristaline” heated display cabinets, on open cupboard or with heated chamber - 3 levels

Trays		Unit on open cupboard			Unit with heated chamber			
Tray capacity	Item no.	Power (w)	Length	Price in € (plus VAT) Stainless steel top	Item no.	Power (w)	Length	Price in € (plus VAT) Stainless steel top
2 GN1/1	VCO3CL09ES	2,550	950	17,429	VCO3CE09ES	4,150	950	18,698
3 GN1/1	VCO3CL12ES	4,270	1,250	20,169	VCO3CE12ES	5,870	1,250	21,677
4 GN1/1	VCO3CL16ES	4,700	1,600	21,807	VCO3CE16ES	6,300	1,600	23,919
5 GN1/1	VCO3CL20ES	6,620	2,000	24,373	VCO3CE20ES	9,820	2,000	24,099
6 GN1/1	VCO3CL23ES	8,540	2,300	30,393	VCO3CE23ES	11,740	2,300	33,099
7 GN1/1	VCO3CL26ES	9,170	2,600	32,746	VCO3CE26ES	12,370	2,600	38,320

Ask us about our plan stone and granite tops.

“ÉLÉGANCE” HEATED DISPLAY CABINETS, 1 LEVEL ON OPEN CUPBOARD OR WITH HEATED CHAMBER

Enodis
ADULT

Easy'
Serve

HEATED
UNITS



DESCRIPTION

AISI 304 stainless steel structure. AISI 304 stainless steel top thickness 2 mm. Rounded front edge. Laminate exterior. 15 mm elevation. Includes 3 stainless steel handrails. Rounded heated display cabinet. Temperature-holding surface and shelf made of GN1/1 black tempered glass panels heated underneath by adhesive elements. Ultra temperature uniformity at 90°C. Open on customer side. Curved glass cover on hydraulic cylinders for easy lifting and cleaning available as add-on. Power 400 v 3-phase. 2 sliding Plexiglass doors. LED lighting. Touch-key controls.

Adult unit height overall dimensions: 1,700 mm

“Élégance” heated display cabinets, on open cupboard or with heated chamber - 1 level

Trays		Unit on open cupboard		
Tray capacity	Item no.	Power (w)	Length	Price in € (plus VAT) Stainless steel top
2 GN1/1	VCO1AL09ES	1,490	950	13,274
3 GN1/1	VCO1AL12ES	2,350	1,250	14,383
4 GN1/1	VCO1AL16ES	2,780	1,600	16,140
5 GN1/1	VCO1AL20ES	3,740	2,000	18,078

Unit with heated chamber			
Item no.	Power (w)	Length	Price in € (plus VAT) Stainless steel top
VCO1AE09ES	3,090	950	15,641
VCO1AE12ES	3,950	1,250	16,975
VCO1AE16ES	4,380	1,600	19,004
VCO1AE20ES	6,940	2,000	21,237

Ask us about our plan stone and granite tops.

“ÉLÉGANCE” HEATED DISPLAY CABINETS, 2 LEVELS ON OPEN CUPBOARD OR WITH HEATED CHAMBER

Enodis
ADULT

Easy'
Serve



DESCRIPTION

AISI 304 stainless steel structure. AISI 304 stainless steel top thickness 2 mm. Rounded front edge. Laminate exterior. 15 mm elevation. Includes 3 stainless steel handrails. Rounded heated display cabinet. Temperature-holding surface and 2 shelves made of GN1/1 black tempered glass panels heated underneath by adhesive elements. Ultra temperature uniformity at 90°C. Open on customer side. Curved glass cover on hydraulic cylinders for easy lifting and cleaning available as add-on. Power 400 v 3-phase. 2 sliding Plexiglass doors. LED lighting. Touch-key controls.

Adult unit height overall dimensions: 1,700 mm

“Élégance” heated display cabinets - on open cupboard or heated chamber - 2 levels

Trays		Unit on open cupboard			Unit with heated chamber			
Tray capacity	Item no.	Power (w)	Dim. W x D x H	Price in € (plus VAT) Stainless steel top	Item no.	Power (w)	Length	Price in € (plus VAT) Stainless steel top
2 GN1/1	VCO2AL09ES	2,020	950	15,573	VCO2AE09ES	3,620	950	17,941
3 GN1/1	VCO2AL12ES	3,310	1,250	17,175	VCO2AE12ES	4,910	1,250	19,766
4 GN1/1	VCO2AL16ES	3,740	1,600	19,349	VCO2AE16ES	5,340	1,600	22,216
5 GN1/1	VCO2AL20ES	5,180	2,000	21,685	VCO2AE20ES	7,180	2,000	24,844

Ask us about our plan stone and granite tops.

HEATED UNITS - ADD-ONS

Enodis
ADULT



HEATED
UNITS

COMPATIBLE ADD-ONS FOR HEATED UNITS		
Item no.	Name	Price in € (plus VAT)
EMB08	Lower shelf for unit on open cupboard or intermediate shelf for heated chamber for unit length 800 mm	292
EMB09	Lower shelf for unit on open cupboard for unit length 950 mm	328
EMB12	Lower shelf for unit on open cupboard or intermediate shelf for heated chamber for unit length 1,200 mm	338
EMB13	Lower shelf for unit on open cupboard for unit length 1,250 mm	381
EMB16	Lower shelf for unit on open cupboard or intermediate shelf for heated chamber for unit length 1,600 mm	396
EMB20	Lower shelf for unit on open cupboard or intermediate shelf for heated chamber for unit length 2,000 mm	489
EMB23	Lower shelf for unit on open cupboard or intermediate shelf for heated chamber for unit length 2,300 mm	561
EMB26	Lower shelf for unit on open cupboard for unit length 2,600 mm	632
PVDV	Additional charge for vibrated top (per LM)	393
BPM	Mirror polished front edge (per LM)	162
CEPO	Laminate end panel (per unit)	490
MRGE800	1 x GN1/1 guide rail frame for heated chamber (entrance 325 mm) for unit length 800 mm	438
MRGE1200	2 x GN1/1 guide rail frames for heated chamber (entrance 325 mm) for unit length 1,200 mm	875
MRGE1600	2 x GN1/1 guide rail frames for heated chamber (entrance 325 mm) for unit length 1,600 mm	919
MRGE2000	2 x GN1/1 guide rail frames for heated chamber (entrance 530 mm) for unit length 2,000 mm	1,010
MRGE2300	2 x GN1/1 guide rail frames for heated chamber (entrance 530 mm) for unit length 2,300 mm	1,010
RPP412I	Set of 4 stainless steel wheels diameter 125 mm (2 with brakes)	316
PCN220	16A power socket not protected/connected (per unit)	167
PCA	Arnould socket (per unit)	338
PCTri	Tri-phase socket (per unit)	281
TBCAV	Front control panel	393
TBCD	Right-side customer-facing control panel	393
TBCG	Left-side customer-facing control panel	393
ALH	Power supply via the top from a cabinet (maximum bar height 3,000 mm with mobile stainless steel plate to be fixed to the ceiling)	469
VOLTSM	Single-phase voltage instead of 3-phase	259
BIPR	Protective stainless steel strip (between counter top and tray slide) (per LM)	170
HSPERPI	Special tray slide height (815 mm to 830 mm elevation) (per cabinet)	294
REGETC	Additional charge for EasyTouch controls on cold unit with USB socket and dynamic lighting	669
LATERAL PANE	Lateral protective pane for bain-marie sneeze guard.	797
BT60	60 mm dropped edge	924

ADD-ONS FOR VITROCHO UNIT ON OPEN CUPBOARD WITH SHELF		
Item no.	Name	Price in € (plus VAT)
SBI06	Stainless steel* holder for GN1/1-65 gastro tray	205
SBI10	Stainless steel* holder for GN1/1-100 gastro tray	206
PDV60	60 mm recess for top with vitro plate (additional charge). Other recess dimensions are available on request	645
PDV60-3F	60 mm recess for vitro plate on 3 sides	2,606

DISPLAY COUNTER ADD-ONS		
Item no.	Name	Price in € (plus VAT)
PVHP530	Additional charge for display counter height 530 mm	171

04

AUXILIARY UNITS

Technical Information

- **All AISI 304 (18-10) stainless steel** construction .
- AISI 304 stainless steel **top thickness 2 mm** with 220 grain satin polish (**scotch-brite**).
Customer side counter surface profile 20 mm rounded edge with **110 mm drop**.
Service side counter surface straight edge with **60 mm drop**.
 Available as add-on: granite or reconstituted stone top thickness 30 mm (one piece per unit).
 Granite or reconstituted stone top finished with straight edge on service side and end and rounded edge on customer side.
- Depth 830 mm, height 900 mm on stainless steel base height 180 mm adjustable -25/+50 mm.
- Units must be bolted at front and rear with sealant between **clean edge** panelling.
- Tray slide brackets in AISI 304 stainless steel fitted to frame through laminated front to ensure tray slide is fully aligned.
- **Standard stainless steel tray rail 3 profiled bars diameter 32 mm (included in unit price)**.
 Available as add-on: granite rail, reconstituted stone rail, glass rail or laminate rail.
- Customer side **façade** as standard in **water-repellent melamine** coated in double-sided laminate **thickness 20 mm. 15 mm elevation** with lower stainless steel corner guard.
 Available on request: 180 mm to 15 mm façade elevation with lower stainless steel corner guard.
 Panels are fitted with an interlocking clip system and held in place by brackets.
 Service side fascia panel attached with easily removable screws for access.
- **250 colours** to choose from our colour chart.

Our most POPULAR PRODUCTS

Endis

ADULT

Easy'
Serve

Loose units

Storage unit on open cupboard or open with adjustable floor and shelf, or with sliding doors (note: 800 mm unit comes with swing door).

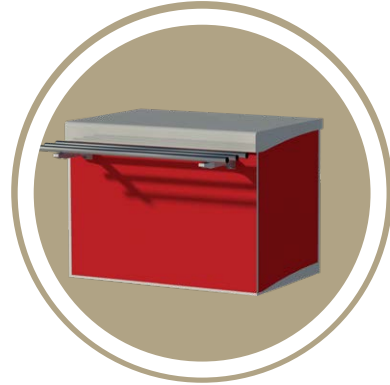

Corner units

Internal corner units: Open with floor and adjustable shelf on service side. External corner units: Laminate façade and rail on customer side.



Utensil dispensers

Constant output glass dispensers. Capacity: 6 to 10 baskets (500 x 500). Constant output hot plate storage and dispensers. Capacity: 110 plates. Power: 110 W. Constant output tray dispensers. Capacity: 110 trays.

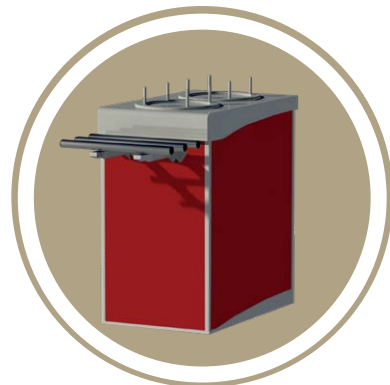

Trolley storage unit

AISI 304 stainless steel thickness 2 mm. Rounded front edge. Laminate façade with 15 mm elevation.

Stainless steel tray slide comes with 3 bars.

U-shaped version available for single trolley or E-shaped for 2.

Trolleys not included.

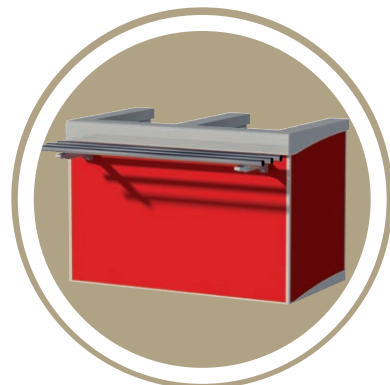

Our most POPULAR PRODUCTS

Endis

ADULT

Easy'
Serve

Cash desks

Unit with or without return arm.
Foot rest.
Lockable stainless steel drawer with key.
Top surface Cable duct.
220 V single-phase socket.

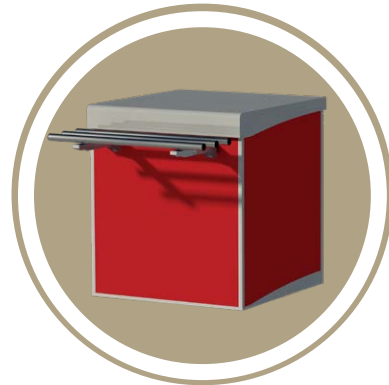

Queue barriers

Made from 40 mm brushed stainless bars with stainless steel fixing plate.
Height 900 mm



Front elements

A connecting element can be used to join two units to modify your configuration or it can be used as trolley storage.



Trays slides

Standard: separate tray slide for each unit consisting of 3 brushed stainless steel bars diameter 32 mounted on stainless steel brackets.
Tray slide also available in stained beech wood, granite (thickness 30 mm), tempered glass or laminate (with 2 stainless steel slide bars).

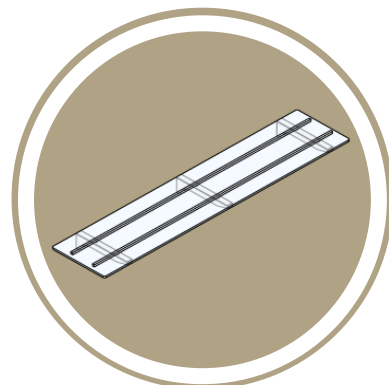

SERVING COUNTER SNEEZE GUARD

Enodis
ADULT

Easy'
Serve

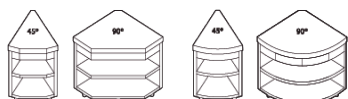

servicing counter

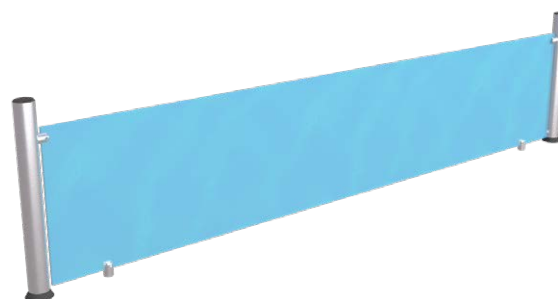

vertical glass sneeze guard

DESCRIPTION

AISI 304 stainless steel structure. AISI 304 stainless steel top thickness 2 mm. Rounded front edge. Laminate façade with 15 mm elevation. Includes 3-bar stainless steel handrail. Loose open unit with 250 mm recess (granite units have 220 mm recess) to fit other modules (not provided). The recess features fully connected and flush power sockets. 240 v single-phase power supply. Other recess dimensions are available on request.

Serving unit - compartment depth 700 mm

Item no.	Number of sockets	Length	Price in € (plus VAT) Stainless steel top
MNOK2ES	2	1,200	4,837
MNOD3ES	3	1,400	4,375
MNOK3ES	3	1,600	5,801
MNOD4ES	4	1,800	6,372
MNOK4ES	4	2,000	5,076
MNOD5ES	5	2,200	7,143
MNOK5ES	5	2,400	5,405

Ask us about our plan stone and granite tops.

Vertical sneeze guard - AISI 304 stainless steel bracket

Item no.	Length	Price in € (plus VAT)
SPHI11	1,100	585
SPHI13	1,300	746
SPHI15	1,500	803
SPHI17	1,700	952
SPHI19	1,900	977
SPHI21	2,100	1,052
SPHI23	2,300	1,058
SPHI25	2,500	1,161

LOOSE UNITS ON OPEN CUPBOARD- WITH OPEN OR CLOSED STORAGE

Enodis
ADULT

Easy'
Serve

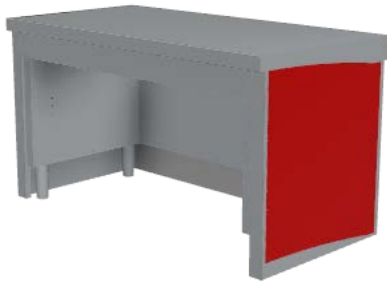

on open cupboard

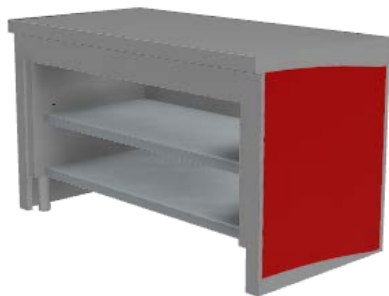

with open storage

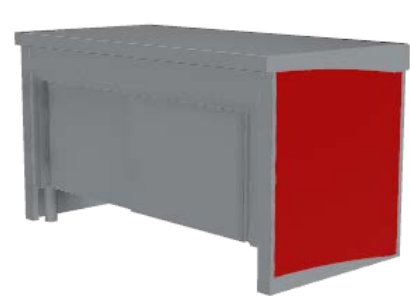

with closed storage

DESCRIPTION

AISI 304 stainless steel structure. AISI 304 stainless steel top thickness 2 mm. Rounded front edge. Laminate façade with 15 mm elevation. Includes 3-bar stainless steel handrail. Storage units with adjustable floor and shelf. Storage unit with sliding doors (note: 800 mm unit comes with swing door).

Loose units

Unit on open cupboard		
Length	Item no.	Price in € (plus VAT)
Stainless steel top		
800	MNBL08ES	3,106
1,200	MNBL12ES	3,658
1,600	MNBL16ES	4,323
2,000	MNBL20ES	4,999
2,300	MNBL23ES	5,427

Unit with open storage	
Item no.	Price in € (plus VAT)
Stainless steel top	
MNO08ES	3,569
MNO12ES	4,286
MNO16ES	5,112
MNO20ES	5,978
MNO23ES	4,304

Unit with closed storage	
Item no.	Price in € (plus VAT)
Stainless steel top	
MNF08ES	3,632
MNF12ES	4,645
MNF16ES	5,486
MNF20ES	6,464
MNF23ES	4,921

Ask us about our plan stone and granite tops.

EXTERNAL CORNER UNITS WITH ANGLED OR ROUNDED CORNERS

Enodis
ADULT

Easy'
Serve

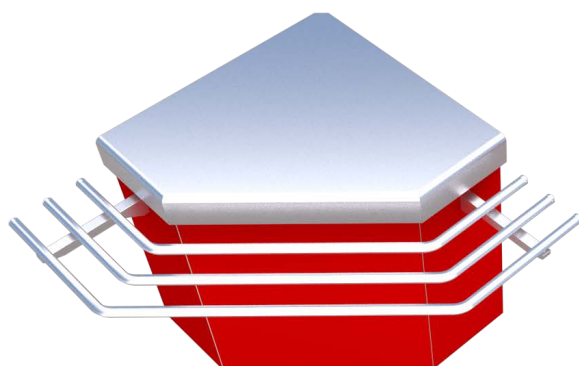

MAE90ES
angled corners

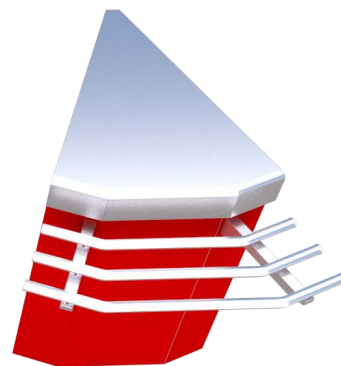

MAE45ES
angled corners

DESCRIPTION

AISI 304 stainless steel structure. AISI 304 stainless steel top thickness 2 mm. Rounded front edge. Laminate façade with 15 mm elevation. Includes 3-bar stainless steel handrail.

External corner units with angled corners

Item no.	Description	Price in € (plus VAT) Stainless steel top
MAE90ES	90° corner (laminated façade on customer side). Unit (top + trim)	3,622
MAE45ES	45° corner (laminated façade on customer side). Unit (top + trim)	2,316

Ask us about our plan stone and granite tops.

Rounded external corner units

Item no.	Description	Price in € (plus VAT) Stainless steel top
MAEC90ES	90° corner (laminated façade on customer side). Unit (top + trim)	5,310
MAEC45ES	45° corner (laminated façade on customer side). Unit (top + trim)	3,990

Ask us about our plan stone and granite tops.

INTERNAL CORNER UNITS WITH ANGLED OR ROUNDED CORNERS

Enodis
ADULT

Easy'
Serve

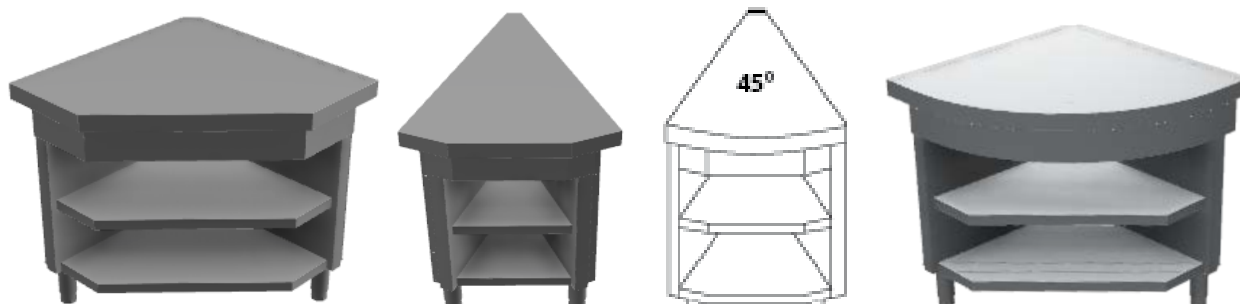

MAI90ES

angled corners

MAI45ES

MAIC45ES

MAIC90ES

rounded edges

DESCRIPTION

Unit top with 3 corners and intermediate floor and shelf.

Internal corner units with angled corners

Item no.	Description	Price in € (plus VAT) Stainless steel top
MAI90ES	90° corner (open on service side). Unit (top + trim)	3,930
MAI45ES	45° corner (open on service side). Unit (top + trim)	3,286
PS90ES	90° corner panel (open on service side). Top only	1,149
PS45ES	45° corner panel (open on service side). Top only	960

Ask us about our plan stone and granite tops.

DESCRIPTION

Unit top with rounded edges intermediate floor and shelf.

Rounded internal corner units

Item no.	Description	Price in € (plus VAT) Stainless steel top
MAIC90ES	90° corner (open on service side). Unit (top + trim)	5,357
MAIC45ES	45° corner panel (open on service side). Top only	3,807

Ask us about our plan stone and granite tops.

GLASS, PLATE AND TRAY DISPENSERS

Enodis
ADULT

Easy'
Serve

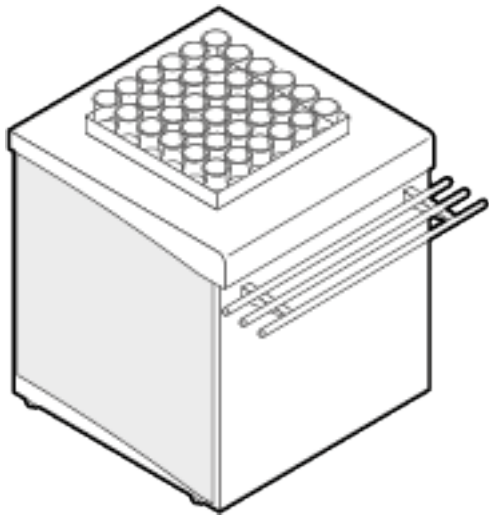

glass dispensers

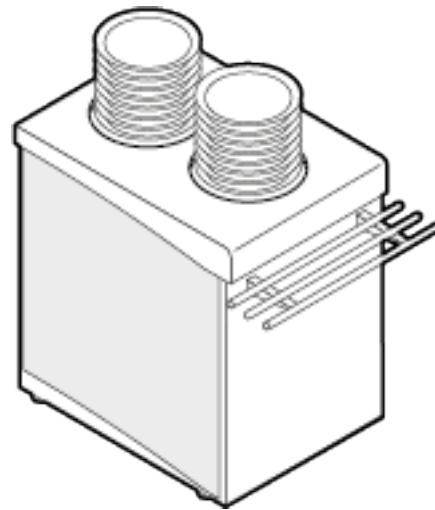

plate dispensers

DESCRIPTION

AISI 304 stainless steel structure. AISI 304 stainless steel top thickness 2 mm. Rounded front edge. Laminate façade with 15 mm elevation. Includes 3-bar stainless steel handrail.

Constant output dispenser for storing and dispensing

- glasses. Capacity: 6 to 10 baskets (500 x 500)
- heated plates. Capacity: 110 plates. Power: 110 w
- trays. Capacity: 110 trays.

Utensil dispensers

Item no.	Length	Description	Price in € (plus VAT) Stainless steel top
DVA80ES	800	Glass dispensers	5,032
DAA45ES	500	Plate dispenser	6,157
DPA80ES	800	Tray dispenser	5,032

Ask us about our plan stone and granite tops.

TROLLEY STORAGE UNITS

Enodis
ADULT

Easy'
Serve

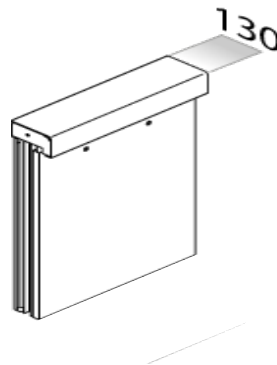

DESCRIPTION

AISI 304 stainless steel. Stainless steel top thickness 2 mm. Rounded front edge. Laminate façade with 15 mm elevation. Includes 3-bar stainless steel handrail.
Unit for trolleys (not included). Display counters can be added to form a superstructure (depending on model).

Trolley storage units.

Item no.	Description	Length	Stainless steel top
EF802BDR	U-shaped trolley storage unit	800	3,971
EF143BDR	E-shaped trolley storage unit	1,400	5,810

CASH DESK WITH LATERAL ARM WITHOUT LATERAL ARM

Enodis
ADULT

Easy'
Serve



DESCRIPTION

AISI 304 stainless steel structure. AISI 304 stainless steel top thickness 2 mm. Rounded front edge. Laminate façade with 15 mm elevation. Includes 3-bar stainless steel handrail. Unit with or without return arm. Foot rest. Lockable stainless steel drawer with key. Cable entry aperture on top surface top. Width: 830 mm, height: 900 mm. Socket not connected.

Cash desks

Item no.	Length	Description	Price in € (plus VAT) Stainless steel top
CA50GES	500	Left side unit without lateral arm	3,091
CA50DES	500	Right side unit without lateral arm	3,091
CA80FES	800	Customer-facing unit	3,381
CA12BDES	1,200	With right-side lateral arm	4,227
CA12BGES	1,200	With left-side lateral arm	4,227
CA15BDES	1,500	With right-side lateral arm	4,907
CA15BGES	1,500	With left-side lateral arm	4,907

Ask us about our plan stone and granite tops.



Enodis

RAILS AND RAILINGS AVAILABLE IN: GRANITE, GLASS AND LAMINATE

Enodis
ADULT

Easy'
Serve

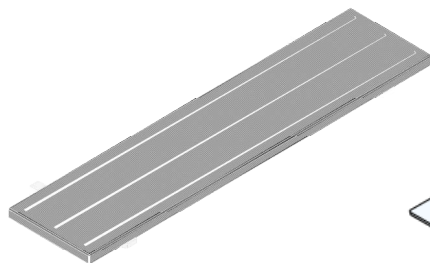

reconstituted stone & granite rails

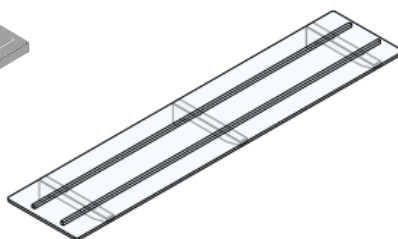

rails with LED lighting (available as add-on)

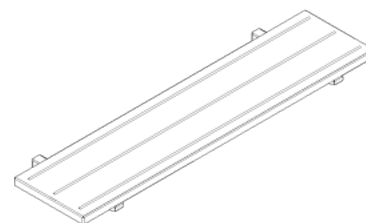

laminate rails

DESCRIPTION

Tray slides available in various materials (an additional charge will apply).

- Granite rail thickness 30 mm on stainless steel brackets. 3 stainless steel bars for sliding trays
- Tempered glass rail thickness 10 mm on stainless steel brackets includes 2 stainless steel slide bars.
- Laminate rail includes 3 stainless steel slide bars.

Tray slides

Description
Additional charge for 500 mm unit
Additional charge for 600 mm unit
Additional charge for 800 mm unit
Additional charge for 900 mm unit
Additional charge for 1,200 mm unit
Additional charge for 1,250 mm unit
Additional charge for 1,400 mm unit
Additional charge for 1,600 mm unit
Additional charge for 2,000 mm unit
Additional charge for 2,000 mm unit
Assembly for 45° corner
Assembly for 90° corner
Additional charge for 90° corner on curved unit
Additional charge for 45° corner on curved unit
For 1,600 mm rectangular salad'bar
For 2,000 mm rectangular salad'bar
For 2,300 mm rectangular salad'bar
For 1,400 mm rectangular salad'bar
For 1,800 mm rectangular salad'bar

Glass	
Item no.	Price in € (plus VAT)
RV08	632
RV12	934
RV13	960
RV16	1,227
RV20	1,851
RV23	1,923
AV45	2,055
AV90	2,837
RVMA90	2,909
RVMA45	2,225
RV16SB	2,449
RV20SB	3,701
RV23SB	3,843
RV14SBO	6,897
RV18SBO	8,269

Laminate	
Item no.	Price in € (plus VAT)
RS05	398
RS06	447
RS08	461
RS09	475
RS12	660
RS13	680
RS14	704
RS16	849
RS20	1,351
RS23	1,363
AS45	1,383
AS90	1,928
RSMA90	2,085
RSMA45	1,495
RS16SB	1,692
RS20SB	2,697
RS23SB	2,724
RS14SBO	5,340
RS18SBO	6,435

Please ask us about our reconstituted stone & granite rails.

STAINLESS STEEL TRAY SLIDES & QUEUE RAILINGS

Enodis
ADULT

**Easy'
Serve**



stainless steel rail slide included

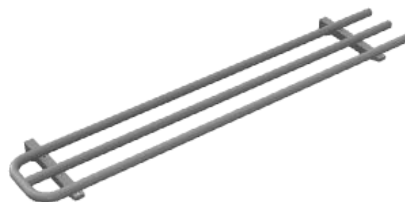

with end bracket

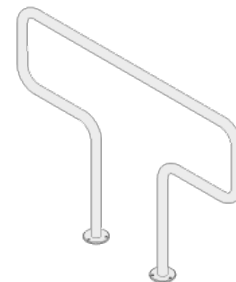

stainless steel queue railing

DESCRIPTION

Tray slide consists of 3 bars.
Standard: separate tray slide for each unit consisting of 3 brushed stainless steel bars diameter 32 mounted on stainless steel brackets.

3-bar stainless steel rails

Item no.	Name	Price in € (plus VAT)
RPI3	3-bar stainless steel rail goes with the self-service unit (per linear metre)	284
MVRPI305	Deduction when purchased without stainless steel rail for 500 mm unit	-130
MVRPI306	Deduction when purchased without stainless steel rail for 600 mm unit	-157
MVRPI308	Deduction when purchased without stainless steel rail for 800 mm unit	-209
MVRPI309	Deduction when purchased without stainless steel rail for 900 mm unit	-235
MVRPI312	Deduction when purchased without stainless steel rail for 1,200 mm unit	-338
MVRPI313	Deduction when purchased without stainless steel rail for 1,250 mm unit	-326
MVRPI314	Deduction when purchased without stainless steel rail for 1,400 mm unit	-391
MVRPI315	Deduction when purchased without stainless steel rail for 1,500 mm unit	-522
MVRPI316	Deduction when purchased without stainless steel rail for 1,600 mm unit	-445
MVRPI320	Deduction when purchased without stainless steel rail for 2,000 mm unit	-522
MVRPI323	Deduction when purchased without stainless steel rail for 2,300 mm unit	-600
MVRPI326	Deduction when purchased without stainless steel rail for 2,600 mm unit	-866

DESCRIPTION

Made from 40 mm brushed stainless bars with stainless steel fixing plate. Height 900 mm.

Stainless steel rails diameter 40

Item no.	Length	Price in € (plus VAT)
RCB12ES	1,200	712

ADD-ONS FOR AUXILIARY UNITS

Enodis
ADULT



ADD-ONS FOR AUXILIARY UNITS		
Item no.	Description	Price in € (plus VAT)
EMB08	Lower shelf for unit on open cupboard for unit length 800 mm	292
EMB09	Lower shelf for unit on open cupboard for unit length 900 mm	328
EMB10	Lower shelf for unit on open cupboard for unit length 1,000 mm	312
EMB12	Lower shelf for unit on open cupboard for unit length 1,200 mm	338
EMB14	Lower shelf for unit on open cupboard for unit length 1,400 mm	387
EMB15	Lower shelf for unit on open cupboard for unit length 1,500 mm	389
EMB16	Lower shelf for unit on open cupboard for unit length 1,600 mm	396
EMB17	Lower shelf for unit on open cupboard for unit length 1,700 mm	471
EMB20	Lower shelf for unit on open cupboard for unit length 2,000 mm	489
EMB23	Lower shelf for unit on open cupboard for unit length 2,300 mm	561
PVDV	Additional charge for vibrated top (per LM)	393
BPM	Mirror polished front edge (per LM)	162
CEPO	Laminate end panel (per unit)	490
CEPORPI	Laminate side with rounded lateral edge and rail (per unit)	1,110
PLE	Stainless steel plinths with 150 mm elevation (per LM)	222
DGN1	Cut-out for GN1/1 (tray not included)	154
DGN2	Cut-out for GN2/1 (tray not included)	209
AGC	Air vent on customer side via opening in the laminate (per unit)	870
RPP412I	Set of 4 stainless steel wheels diameter 125 mm (2 with brakes) for < 2,000 mm unit	316
PCN220	16A power socket not protected/connected (per unit)	167
PCA	Arnould socket (per unit)	338
PCTri	Tri-phase socket (per unit)	281
RJ45	Socket for PC RJ45 (per unit)	176
FCPC	Lock with key for loose unit with sliding door (one for each unit)	99
TBCAV	Front control panel	393
TBCD	Right-side customer-facing control panel	393
TBCG	Left-side customer-facing control panel	393
ALH	Power supply via the top from a cabinet (maximum bar height 3,000 mm with mobile stainless steel plate to be fixed to the ceiling)	469
BIPR	Protective stainless steel strip (between counter top and tray slide) (per LM)	170
HSPERPI	Special tray slide height (815 mm to 830 mm elevation) (per cabinet)	294
BSC	Ventilated tank separator bar (per unit)	62
TDSB	Smoked Plexiglas plate shelf for salad bar + fixings (per unit)	356
BGPR	Protective granite strip (between counter top and tray slide) (Per LM)	401
LEDB	Additional charge for White LED lighting in glass rail or underneath rail, work counter or plinth	486
LEDRGB	Additional charge for Multicolour LED lighting in glass rail or underneath rail, work counter or plinth	603
REGETC	Additional charge for Easy'Touch controls for heated unit with USB socket and dynamic lighting	669
REGETF	Additional charge for Easy'Touch controls for heated unit with USB socket and dynamic lighting	784

VERTICAL SNEEZE GUARD ADD-ONS		
Item no.	Name	Price in € (plus VAT)
TVO250	Glass plate shelf	253
TGO250	Granite plate shelf	351
TIO250	Stainless steel plate shelf	241



05 ORGANISERS

Technical Information

- **All AISI 304 (18-10) stainless steel** construction .
- AISI 304 stainless steel **top thickness 2 mm** with 220 grain satin polish (**scotch-brite**).
Customer side counter surface profile 20 mm rounded edge with **110 mm drop**.
Service side counter surface straight edge with **60 mm drop**.
 Available as add-on: granite or reconstituted stone top thickness 30 mm (one piece per unit).
 Granite or reconstituted stone top finished with straight edge on service side and end and rounded edge on customer side.
- Depth 830 mm, height 900 mm on stainless steel base height 180 mm adjustable -25/+50 mm.
- Units must be bolted at front and rear with sealant between **clean edge** panelling.
- Tray slide brackets in AISI 304 stainless steel fitted to frame through laminated front to ensure tray slide is fully aligned.
- **Standard stainless steel tray rail 3 profiled bars diameter 32 mm (included in unit price)**.
 Available as add-on: granite rail, reconstituted stone rail, glass rail or laminate rail.
- Customer side **façade** as standard in **water-repellent melamine** coated in double-sided laminate **thickness 20 mm. 15 mm elevation** with lower stainless steel corner guard.
 Available on request: 180 mm to 15 mm façade elevation with lower stainless steel corner guard.
 Panels are fitted with an interlocking clip system and held in place by brackets.
 Service side fascia panel attached with easily removable screws for access.
- **250 colours** to choose from our colour chart.

CLEARING UNITS

Enodis
ADULT

Easy'
Serve



DESCRIPTION

AISI 304 stainless steel structure. AISI 304 stainless steel top thickness 2 mm. Rounded front edge. Laminate façade with 15 mm elevation. Includes 3-bar stainless steel handrail. Unit with or without return arm. Foot rest. Lockable stainless steel drawer with key. Cable entry aperture on top surface top. Width: 830 mm, height: 900 mm. Socket not connected.

Loose units on open cupboard

Item no.	Dimensions W x D x H	Price in € (plus VAT)
MNBL08ES	800 x 830 x 900	3,106
MNBL12ES	1,200 x 830 x 900	3,658
MNBL16ES	1,600 x 830 x 900	4,323
MNBL20ES	2,000 x 830 x 900	4,999
MNBL23ES	2,300 x 830 x 900	5,427

Laminate-coated customer side doors - swing or sliding

Swing doors item no.	Swing doors item no.	Description	Price in € (plus VAT)
PBATT08	PCOULC08	Additional charge for 800 mm unit door	921
PBATT12	PCOULC12	Additional charge for 1,200 mm unit door	1,837
PBATT16	PCOULC16	Additional charge for 1,600 mm unit door	1,837
PBATT17	PCOULC17	Additional charge for 1,700 mm unit door	1,837
PBATT20	PCOULC20	Additional charge for 2,000 mm unit door	1,837
PBATT23	PCOULC23	Additional charge for 2,300 mm unit door	1,837

Top with 30 mm recess with diamond pattern

Item no.	Length	Price in € (plus VAT)
DEC510	510 x 510 for 1 bin	695
DEC1020	1,020 x 510 for 2 bins	832
DEC1530	1,530 x 510 for 3 bins	924
DEC2020	2,020	1,231

WASTE-SORTING UNIT

Enodis
ADULT

Easy'
Serve

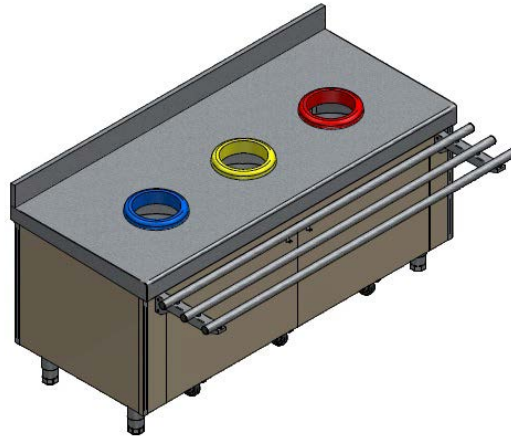

AISI 304 stainless steel structure. AISI 304 stainless steel top thickness 2 mm. Rounded front edge. Laminate façade with 15 mm elevation. Includes 3-bar stainless steel handrail that folds upward. Rear backsplash 100 mm. Comes with mobile bins + coloured collar (please specify).

Loose units on open cupboard - stainless steel top

Item no.	Dimensions W x D x H	Price in € (plus VAT)
MNTA2CES	1,200 x 700 x 750	11,298
MNTA3CES	160 x 700 x 750	13,222

WASTE-SORTING UNIT ADD-ONS		
Item no.	Description	Price in € (plus VAT)
COLLERETTE-C-BLEU	Blue rubber collar for waste sorting chute	185
COLLERETTE-C-JAUNE	Yellow rubber collar for waste sorting chute	185
COLLERETTE-C-ROUGE	Red rubber collar for waste sorting chute	185
COLLERETTE-C-VERTE	Green rubber collar for waste sorting chute	185
PLAQUE TRI SELECTIF	A4 stainless steel sign hooks to front (per unit)	120



WASTE-SORTING UNITS - ADD-ONS

Enodis
ADULT



WASTE-SORTING UNIT ADD-ONS		
Item no.	Name	Price in € (plus VAT)
EMB08	Lower shelf for unit on open cupboard 800 mm	292
EMB12	Lower shelf for unit on open cupboard 1,200 mm	338
EMB16	Lower shelf for unit on open cupboard 1,600 mm	396
EMB17	Lower shelf for unit on open cupboard 1,700 mm	471
EMB20	Lower shelf for unit on open cupboard 2,000 mm	489
EMB23	Lower shelf for unit on open cupboard 2,300 mm	561
CEPO	Laminate end panel (per unit)	490
VDC	Waste chute with anti-shock collar	381
RPP412I	Set of 4 stainless steel wheels diameter 125 mm (2 with brakes) for < 2,000 mm unit	316
DGN1	Cut-out for GN1/1 (tray not included)	154
DGN2	Cut-out for GN2/1 (tray not included)	209
BAR	Anti-runoff edge.	484
DO	Rear backsplash (per linear metre)	614
ARPI3	Stainless steel rails flap	1,025
CE3ES	End bracket	190
AAI3	Corner joint for 2 straight sections	625



CHILD SELF-SERVICE UNITS





CHILD
SELF-SERVICE
UNITS

Enodis

EXAMPLE OF COMPOSITION

Enodis
CHILD



Single-level display counter with curved glass and frontal glass.
Length: 1,500 mm.

Single-level display counter with curved glass.
Length: 715 mm.

Water bain-marie unit on heated chamber with sliding doors.
Tank height 180 mm.
For GN1/1 tray - 150 mm
Length: 1,600 mm
Depth: 820 mm
Height: 870 mm

Front continuity element.
Length: 1,600 mm
Depth: 500
Height: 750 mm

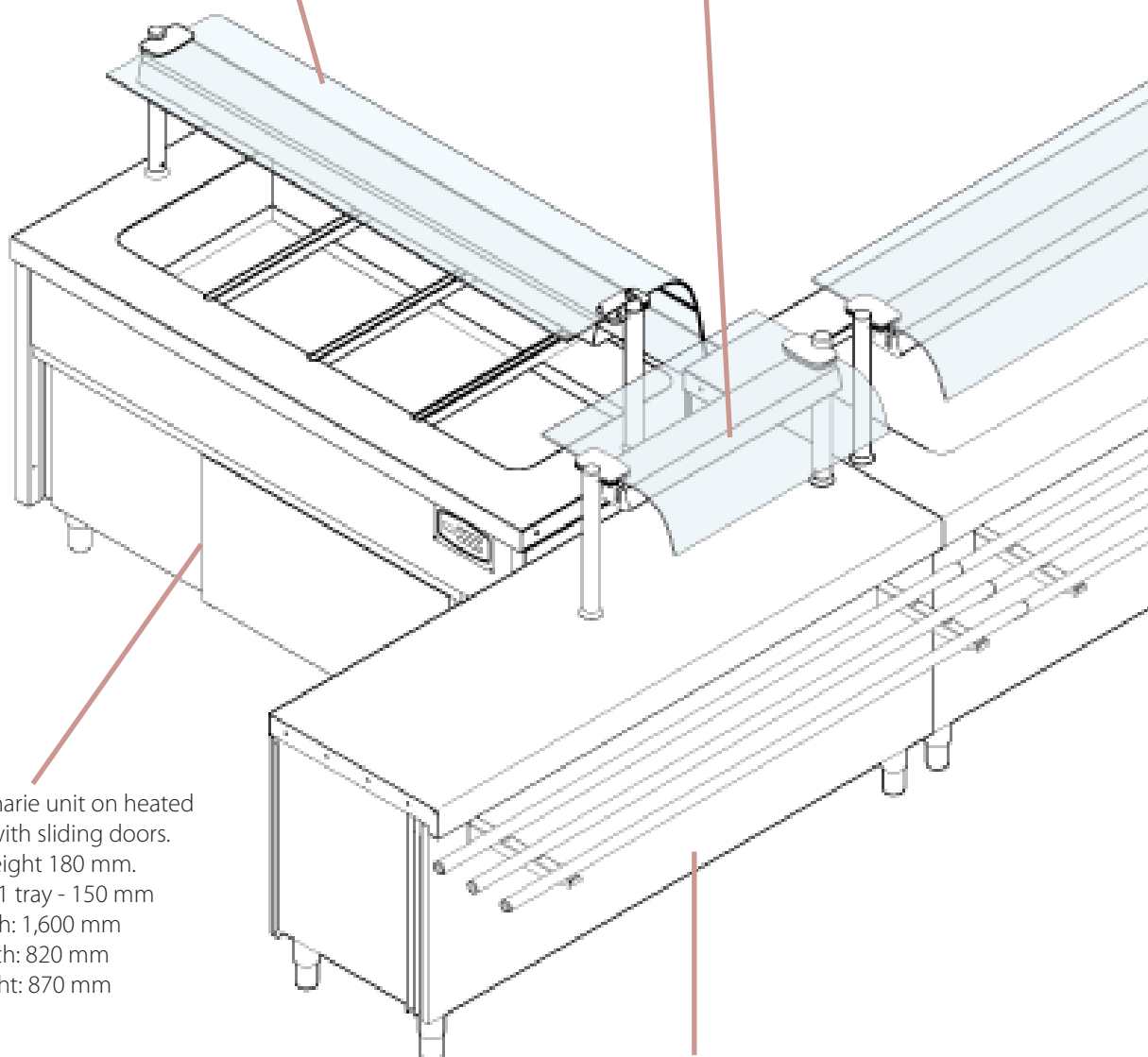

Enodis

CHILD

Prim'
Age

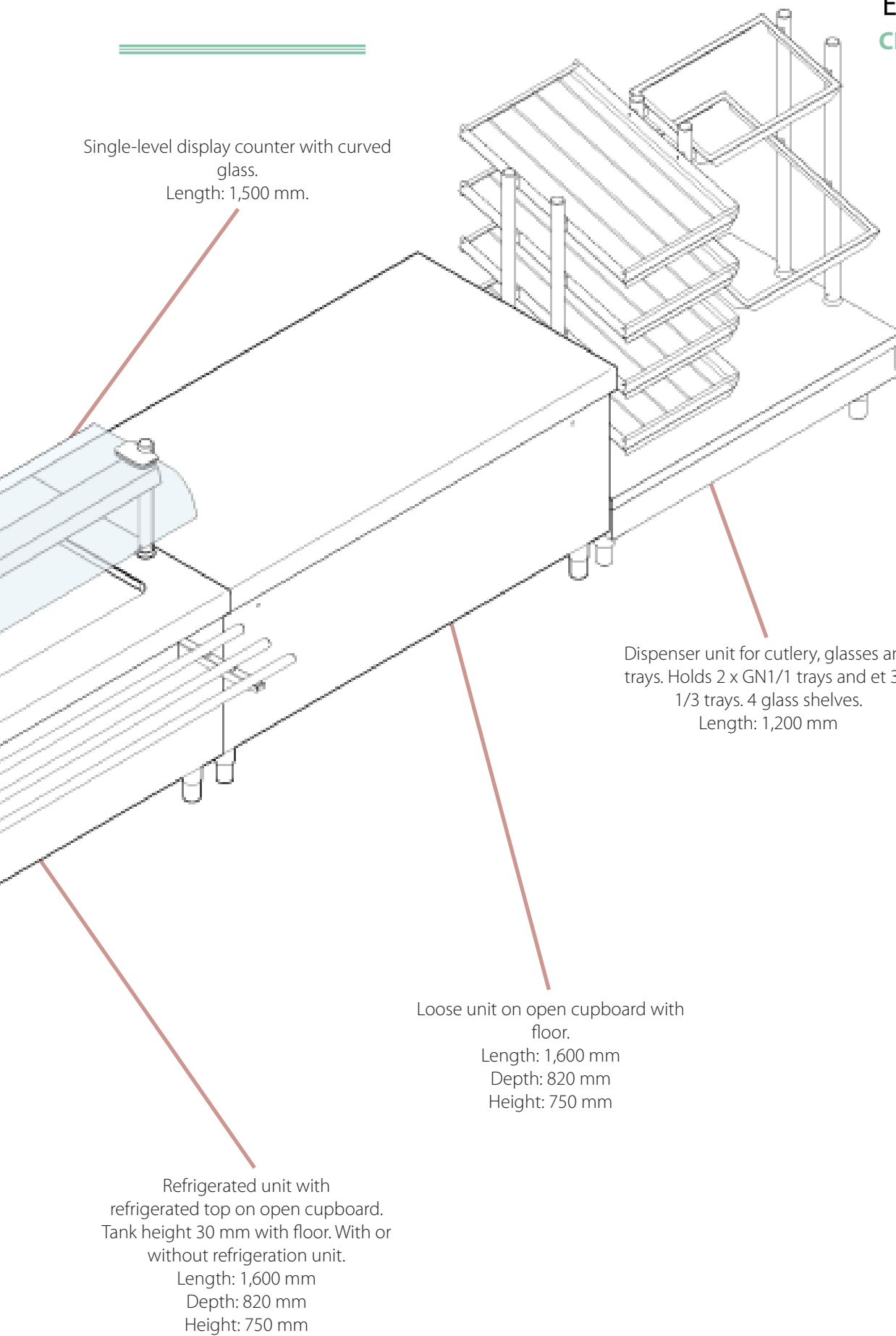

CHILD
SELF-SERVICE
UNITS

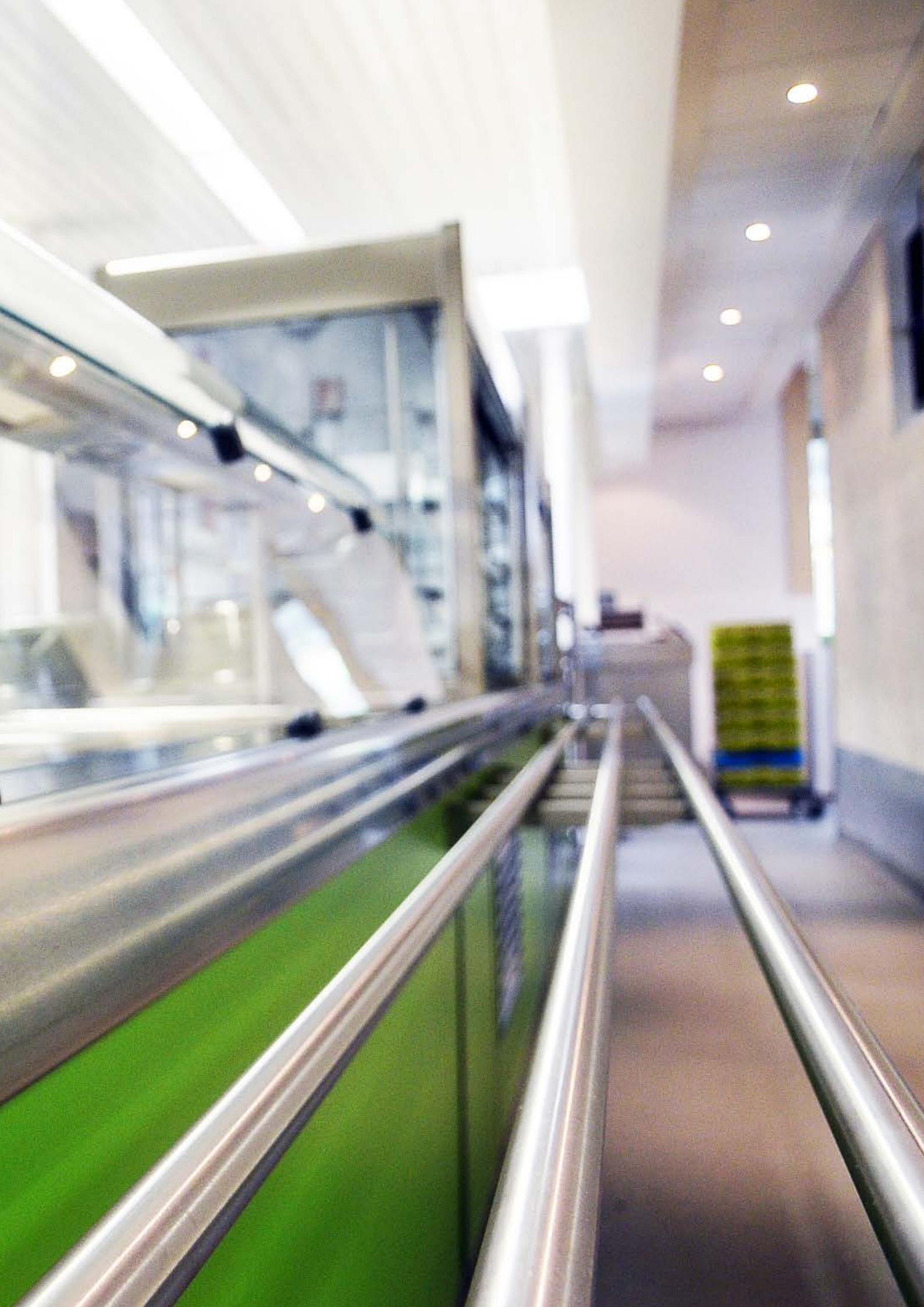

Our most **Enodis** **CHILD** **Prim'Age** **POPULAR PRODUCTS**

Hygienic

Radiant tank
Radiant heat chamber
Tops assembled with clean edges



High performance

Ventilated cooling with removable tank bottom
Refrigeration system noise level 56 dB(A). Comes with removable bottom. Uses refrigerant R455A (GWP: 146)
LED lighting
Touch control with smart clock (available as add-on)

Design

Laminate façade with 15 mm elevation (as standard)
250 colours available
Stainless steel corner guards
Tempered glass rail thickness 10 mm + LED lighting (available as add-on)

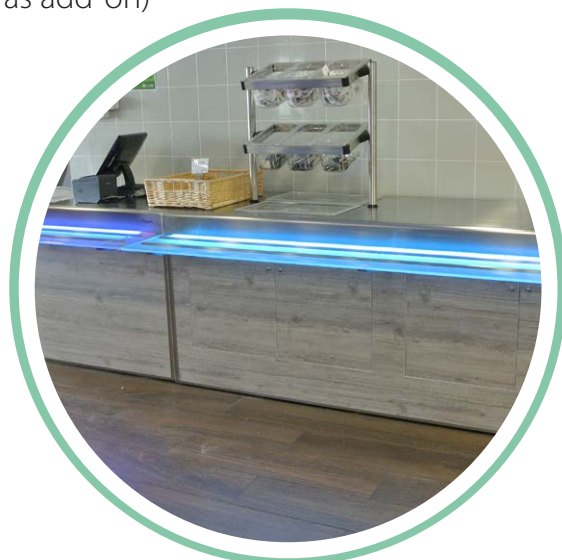

ALL CHILD SELF-SERVICE UNITS

Enedis
CHILD



01

UTENSIL
DISPENSERS

126

02

COLD
UNITS

134

03

HEATED
UNITS

154

ALL CHILD SELF-SERVICE UNITS

Enodis
CHILD



04
AUXILIARY
UNITS

166

180

05
ORGANISERS

CHILD
SELF-SERVICE
UNITS

01

UTENSIL DISPENSERS



Enodis



Enodis

Our most

Enodis
CHILD
Prim'
Age

POPULAR PRODUCTS

Glass racks

AISI 304 stainless steel structure. AISI 304 stainless steel frame with 40 mm bars. Version with stainless steel slide-out grill for storing and displaying glasses. Maximum glass dimensions: diameter 80 x H92 mm. Capacity: 60 glasses/diameter 75 or 54 glasses/diameter 80.

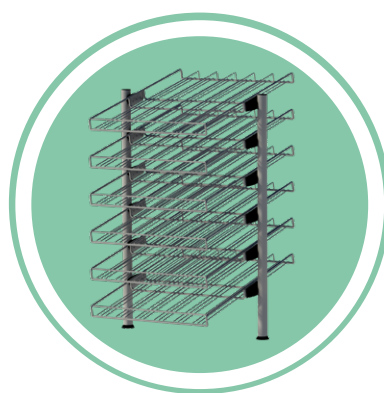

Tray/holder racks

AISI 304 stainless steel structure. AISI 304 Stainless steel frame with 40 mm bars. Rack system for quick restocking by simply swapping trays or holders.

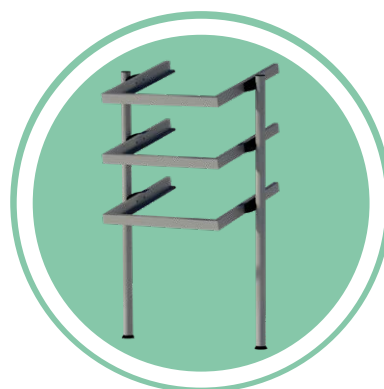

TRAY HOLDERS, BREAD & CUTLERY DISPLAY COUNTERS

Enodis
CHILD
Prim'Age



MBP08PRI



MBP14PRI



PCI072

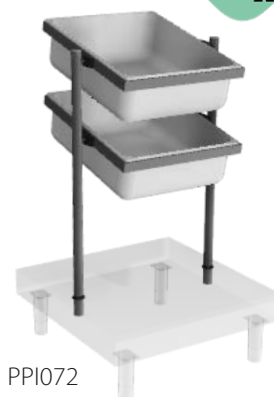

PPI072

DESCRIPTION

Tray holders:
AISI 304 stainless steel structure. Lower units with 4 closed sides for displaying trays or other items.

Tray holders

Item no.	Tray capacity	Length	Stainless steel top - Price in € (plus VAT)
MPB08PRI	2 x 135 trays of 370 x 430	800	1,307
MPB14PRI	4 x 135 trays of 370 x 430	1,400	1,749

DESCRIPTION

Cutlery rack:
AISI 304 stainless steel structure. Polished stainless frame with 40 mm bars to hold GN1/3 polycarbonate cutlery trays. Capacity: 100 sets of cutlery in 3 GN1/3 trays. BPA-free copolyester trays provided.

Cutlery racks

Item no.	Tray capacity	Cutlery capacity	Length	Stainless steel top - Price in € (plus VAT)
PCI071	1 level with 3 x GN1/3 trays	100	750	317
PCI072	2 levels with 3 x GN1/3 trays	200	750	635
PCI141	1 level with 6 x GN1/3 trays	200	1,400	635
PCI142	2 levels with 6 x GN1/3 trays	400	1,400	1,265

DESCRIPTION

Bread trays:
AISI 304 stainless steel structure. Polished stainless frame with 40 mm bars to hold GN2/1 polycarbonate bread trays. Capacity: 150 bread rolls in 1 GN2/1 tray. BPA-free copolyester trays provided.

Bread trays

Item no.	Tray capacity	Bread roll capacity	Length	Stainless steel top - Price in € (plus VAT)
PPI071	1 level with 1 x GN2/1 tray	150	750	401
PPI072	2 levels with 1 x GN2/1 tray	300	750	797
PPI141	1 level with 2 x GN2/1 trays	300	1,400	797
PPI142	2 levels with 2 x GN2/1 trays	600	1,400	1,591

BREAD & TRAY DISPLAY COUNTERS, COMBINED BREAD, CUTLERY & GLASS DISPLAY COUNTERS

Enodis
CHILD
**Prim'
Age**



PCPI072



PMI146G

DESCRIPTION

Bread and cutlery display units
AISI 304 stainless steel structure. Polished stainless frame with 40 mm bars to hold GN1/3 polycarbonate cutlery trays. Capacity: 100 sets of cutlery in 3 GN1/3 trays. BPA-free copolyester trays provided.

Bread and cutlery display units

Item no.	Composition	Cutlery capacity	Bread roll capacity	Length	Price in € (plus VAT)
PCPI072	3 x GN1/3 trays - 100 for cutlery 1 x GN2/1 tray - 200 for bread	100	150	750	714
PCPI142	2 sets of 3 GN1/3 trays - 100 for cutlery 2 x 1 GN2/1 tray - 200 for bread	200	300	1400	1,427

DESCRIPTION

AISI 304 stainless steel structure. Version with stainless steel grid for storing and displaying glasses plus 1 bread tray and 3 cutlery trays. Capacity: 3 cutlery trays (approx. 100 sets of cutlery).
One bread tray: capacity approx. 150 small bread rolls. BPA-free copolyester trays provided.
Maximum glass dimensions: diameter 80 x H92 mm. Capacity: 60 glasses/diameter 75 or 54 glasses/diameter 80.

Combined bread, cutlery & glass display units

Item no.	Cutlery capacity	Bread roll capacity	Glass capacity	Length	Price in € (plus VAT)
PMI71G	100	150	1 grid - 60 glasses	750	1,019
PMI72G	100	150	2 grids - 120 glasses	750	1,322
PMI142G	100	150	2 grids - 120 glasses	1,400	1,322
PMI143G	100	150	3 grids - 180 glasses	1,400	1,623
PMI144G	100	150	4 grids - 240 glasses	1,400	1,925
PMI145G	100	150	5 grids - 300 glasses	1,400	2,228
PMI146G	100	150	6 grids - 360 glasses	1,400	2,530

GLASS AND TRAY RACKS

Enodis
CHILD

Prim'
Age

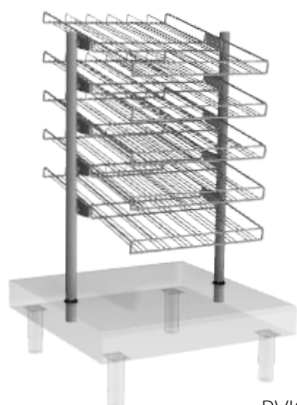

PVI075G

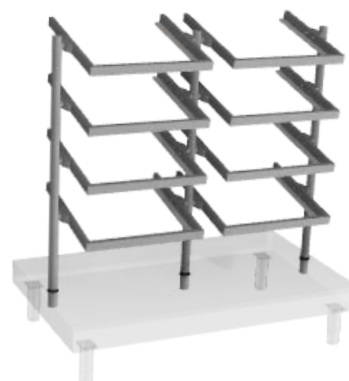

PVI144C

DESCRIPTION

Cutlery rack:

AISI 304 stainless steel structure. Version with stainless steel slide-out grid for storing and displaying glasses.

Maximum glass dimensions: diameter 80 x H92 mm. Capacity: 60 glasses/diameter 75 or 54 glasses/diameter 80

Glass racks

Item no.	Slide-out glass grids	Glass capacity	Length	Price in € (plus VAT)
PVI073G	3 levels	180	750	952
PVI074G	4 levels	240	750	1,269
PVI075G	5 levels	300	750	1,515
PVI076G	6 levels	360	750	1,766
PVI077G	7 levels	420	750	2,001
PVI078G	8 levels	480	750	2,197
PVI141G	2 x 1 level	120	1,400	608
PVI142G	2 x 2 levels	240	1,400	910
PVI143G	2 x 3 levels	36	1,400	1,212
PVI144G	2 x 4 levels	480	1,400	1,515
PVI145G	2 x 5 levels	600	1,400	1,818
PVI146G	2 x 6 levels	720	1,400	2,119

DESCRIPTION

Tray/holder racks:

AISI 304 stainless steel structure. Rack system for quick restocking by simply swapping trays or holders.

Tray/holder racks

Item no.	Levels	Tray capacity	Length	Stainless steel top - Price in € (plus VAT)
PVI73C	3 levels	3	750	1,224
PVI74C	4 levels	4	750	1,632
PVI75C	5 levels	5	750	1,949
PVI143C	2 x 3 levels	6	1,400	2,446
PVI144C	2 x 4 levels	8	1,400	2,945
PVI145C	2 x 5 levels	10	1,400	3,441

SELF-SERVICE AND DISPLAY - ADD-ONS

Enodis
CHILD



SELF-SERVICE AND DISPLAY ADD-ONS		
Item no.	Name	Price in € (plus VAT)
RPP412I	Set of 4 stainless steel wheels diameter 125 mm (2 with brakes)	316
PVDV	Additional charge for vibrated top (Per LM)	393
BPM	Mirror polished front edge (Per LM)	162
PVBC	Additional charge for each additional level with cutlery tray (per level)	308
MVBC	Deduction when purchasing 1 fewer cutlery tray level	-299
PVBP	Additional charge for each additional level with bread tray (per level)	375
MVPB	Deduction when purchasing 1 fewer bread tray level	-377
PVGRI	Additional charge for each additional grid	291
MVGRI	Deduction when purchasing 1 fewer grid	-282
PVCA	Additional charge for each additional level with tray rack (per level).	308
MVCA	Deduction when purchasing 1 fewer rack	-299
PVFSPE	Additional charge for loose unit fixings	128

02

**COLD
UNITS**

Technical Information

- **All AISI 304 (18-10) stainless steel** construction .
- AISI 304 stainless steel **top thickness 2 mm** with 220 grain satin polish (**scotch-brite**).
Customer side counter surface profile 20 mm rounded edge with **110 mm drop**.
Service side counter surface straight edge with **60 mm drop**.
Available as add-on: granite or reconstituted stone top thickness 30 mm (one piece per unit).
Granite or reconstituted stone top finished with straight edge on service side and end and rounded edge on customer side.
- Depth 830 mm, height 750 mm on stainless steel base height 180 mm adjustable -25/+50 mm.
- Units must be bolted at front and rear with sealant between **clean edge** panelling.
- Tray slide brackets in AISI 304 stainless steel fitted to frame through laminated front to ensure tray slide is fully aligned.
- **Standard stainless steel tray rail 3 profiled bars diameter 32 mm (included in unit price)**.
Available as add-on: granite rail, reconstituted stone rail, glass rail or laminate rail.
- Customer side **façade** as standard in **water-repellent melamine** coated in double-sided laminate **thickness 20 mm. 15 mm elevation** with lower stainless steel corner guard.
Available on request: 180 mm to 15 mm façade elevation with lower stainless steel corner guard.
Panels are fitted with an interlocking clip system and held in place by brackets.
Service side fascia panel attached with easily removable screws for access.
- **250 colours** to choose from our colour chart.

Specifications

- **Refrigerated tank with static cooling** with welded rounded corners and diamond pattern toward drain plug. Injected with polyurethane foam insulation. Available with **30 mm or 110 mm recess**. Temperature range -10°C to +5°C
- **Refrigerated tank with ventilated cooling** with welded rounded corners and diamond pattern toward drain plug. Injected with polyurethane foam insulation.
Available with **30 mm or 110 mm recess**. Temperature range -10°C to 5°C.
- **Refrigeration system noise level 56dB(A)**. Uses refrigerant **R455A** (GWP of 146), power supply single-phase 230 volts. **Comes with removable frame**.
- Drip tray included.
- Touch-key controls.
Available as add-on: EasyTouch control panel.
- Other refrigerants available on request: R290.
- Compatible remote units: CO2, R134A, R404A, R407F, R448A, R449A, R452A, R513A, glycolated water (please confirm fluid when placing your order).

Complies with AFNOR standard AC D 40-004 (the French industrial standards authority).

Our most **Enodis** **CHILD** **Prim'Age**

POPULAR PRODUCTS

Refrigerated display units for starters, drinks, salad'bar. Refrigerated tank for starters, drinks, and displaying food on ice

Refrigeration using copper coiling located under the tank with HCFO foam insulation, density 42kg/m³.
Compatible with GN1/1 trays.

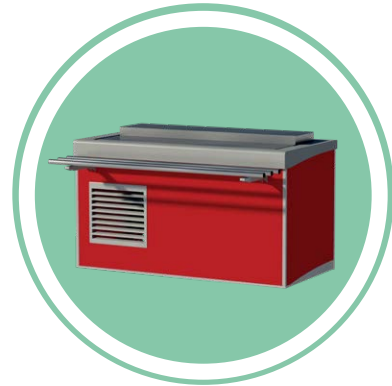

Display counters

Polished stainless steel bars diameter 40 mm. Tempered glass shelf with curved sneeze guard thickness 6 mm. LED lighting (some models only)

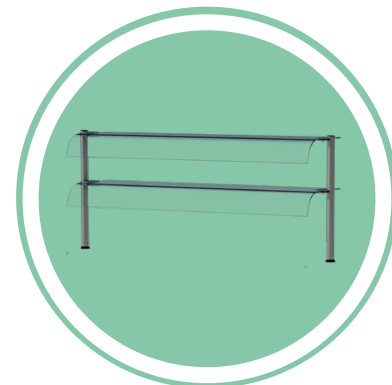

Refrigerated display unit with ventilated tank and salad'bar.

Ventilated tank, base in 2 depth-adjustable parts (30 to 110 mm), GN/14 tray compatible. Oscillating ventilated evaporator.
HCFO foam insulation, density 42kg/m³. Bactericidal UVC lamp available as add-on.
Potentiometer for fan control to optimise operation and energy consumption. Tempered glass shelf with curved sneeze guard on both sides, thickness 6 mm
Tray slide with stainless steel bars diameter 32 mm.



Our most POPULAR PRODUCTS

Enodis
CHILD
Prim'
Age

COLD
UNITS

“Cristaline” display units

Ventilated tank, base in 2 depth-adjustable parts from 30 to 110 mm, GN1/1 tray compatible (oscillating ventilated evaporator). HCFO foam insulation, density 42 kg/m³. Potentiometer for fan control to optimise operation and energy consumption. Rectangular refrigerated display cabinet with rear ventilation. Customer side open with thermal curtain. Curved glass cover on hydraulic cylinders for easy lifting and cleaning available as add-on. 2 sliding doors in double-walled Plexiglas with micro-perforations to allow laminar airflow with front suction to form the air curtain. 2, 3 or 4 height-adjustable shelves (depending on model). LED lighting.

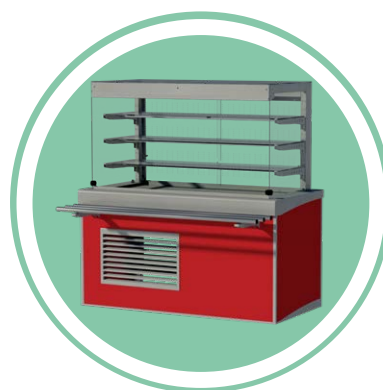

“Élégance” display units

Ventilated tank, base in 2 depth-adjustable parts (30 to 110 mm), GN1/1 compatible (oscillating ventilated evaporator). HCFO foam insulation, density 42 kg/m³. Potentiometer for fan control to optimise operation and energy consumption. Rounded refrigerated display cabinet with rear ventilation. Customer side open with thermal curtain. Curved glass cover on hydraulic cylinders for easy lifting and cleaning available as add-on. 2 sliding doors in double-walled Plexiglas with micro-perforations to allow laminar airflow with front suction to form the air curtain. 2 or 3 height-adjustable shelves (depending on model). LED lighting.



“Cristaline” display units

Trays refrigerated using copper coiling located under the tank with HCFO foam insulation, density 42 kg /m³. Display cabinet with insulated box in top and ventilated evaporator. Front-flow refrigeration and rear air return. Tempered glass sliding doors on service side and fridge roller blind on customer side. Tempered double glazing on both sides. LED lighting on customer side Compatible with GN1/1trays.

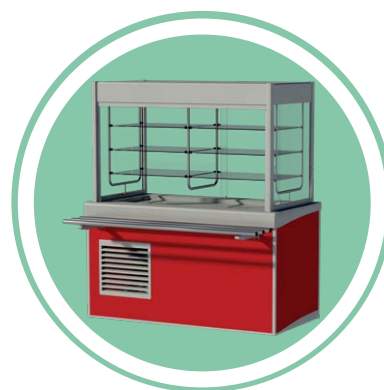

REFRIGERATED UNIT ON OPEN CUPBOARD WITH STATIC COOLING



DESCRIPTION

on open cupboard

container depth 30 mm

AISI 304 stainless steel structure. AISI 304 stainless steel top thickness 2 mm. Rounded front edge. Laminate exterior. 15 mm elevation. Includes 3 stainless steel handrails. Recessed tank, depth 30 mm, drains directly (draining 3/4), condensate drip tray (4 L). Static refrigeration using copper coiling located under the tank with HCFO foam insulation. 240 v single-phase power supply. Noise level with refrigeration unit 56 dB(A). Comes with removable frame. Refrigerant R455A Adjustable tank control. Touch-key controls.

Available without refrigeration unit (comes with vacuum pump, control facility, pressure regulator and evaporator).

Add SG to item number. Ex. MSGHL12DPRI. Condensate drip tray not included.

Refrigerated display unit on open cupboard for starters and desserts

Item no.	Tank	Power (w)	Power (w)	Length	With refrigeration unit Price in
	Tray capacity	Electric	Cooling capacity (W)		€ (plus VAT)
MHL12DPRI	3 GN1/1	350	377	1,200	6,998
MHL16DPRI	4 GN1/1	450	562	1,600	8,404
MHL20DPRI	5 GN1/1	700	753	2,000	8,890
MHL23DPRI	6 GN1/1	700	753	2,300	9,064

Without refrigeration unit Price in
€ (plus VAT)
Stainless steel top
6,422
7,812
8,295
8,560

REFRIGERATED UNITS ON OPEN CUPBOARD WITH STATIC COOLING



on open cupboard



container depth 110 mm

DESCRIPTION

AISI 304 stainless steel. AISI 304 stainless steel top thickness 2 mm. Rounded front edge. Laminate exterior. 15 mm elevation. Includes 3 stainless steel handrails. **Recessed tank**, depth 110 mm, drains directly (3/4 draining), condensate drip tray (4 litres). Static refrigeration using copper coiling located under the tank with HCFO foam insulation. 240 v single-phase power supply. Noise level with refrigeration unit 56 dB(A). Comes with removable frame. Refrigerant R455A Adjustable tank control. Touch-key controls.

Refrigerated beverage units on open cupboard

Item no.	Tank Tray capacity	Power (w) Electric	Power (w) Cooling capacity (W)	Length	With refrigeration unit Price in € (plus VAT)	Without refrigeration unit Price in € (plus VAT)
					Stainless steel top	Stainless steel top
MBL12DPRI	3 GN1/1	350	280	1,200	7,367	6,863
MBL16DPRI	4 GN1/1	450	562	1,600	7,717	7,212
MBL20DPRI	5 GN1/1	700	580	2,000	8,661	8,157
MBL23DPRI	6 GN1/1	700	580	2,300	9,190	8,686

1 & 2 LEVEL DISPLAY COUNTERS IN STAINLESS STEEL WITH SNEEZE GUARD

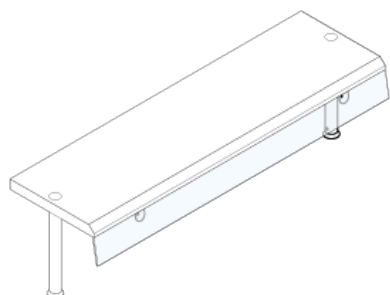

display counter 1 level

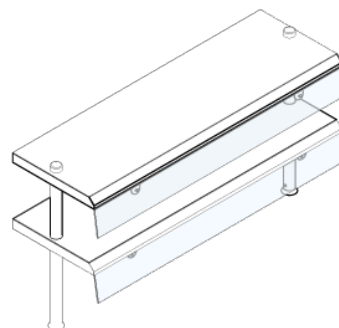

display counter 2 levels

DESCRIPTION

1.8 mm stainless steel display counters with straight glass sneeze guard in 6 mm white tempered glass. Polished stainless steel bars diameter 40 mm. Height 370 mm with 1 level and 640 mm with 2. 240 v single-phase power supply. Available as add-on: one or two under-shelf LED lighting strips for first and/or second shelf.

Stainless steel display counters with sneeze guard - 1 level

Length	GN capacity	Lighting wattage (per shelf)		Single shelf	
		LED	Item no.	Price in € (plus VAT)	
800	2	8	PICS08-I	1,053	
1,200	3	14	PICS12-I	1,170	
1,600	4	20	PICS16-I	1,285	
2,000	5	26	PICS20-I	1,634	
2,300	6	30	PICS23-I	1,793	

Single shelf (for each shelf) + LED lighting	
Item no.	Price in € (plus VAT)
PICS08LED-I	1,367
PICS12LED-I	1,603
PICS16LED-I	1,829
PICS20LED-I	2,303
PICS23LED-I	2,600

Stainless steel display counters with sneeze guard - 2 levels

Length	GN capacity	Lighting wattage		Double shelf	
		LED	Item no.	Price in € (plus VAT)	
800	2	8	PICD08-I	1,606	
1,200	3	14	PICD12-I	1,780	
1,600	4	20	PICD16-I	1,955	
2,000	5	26	PICD20-I	2,481	
2,300	6	30	PICD23-I	2,801	

Double shelves + LED lighting 1 level	
Item no.	Price in € (plus VAT)
PICD08LED1-I	2,057
PICD12LED1-I	2,372
PICD16LED1-I	2,680
PICD20LED1-I	3,381
PICD23LED1-I	3,867

Double shelves + LED lighting 2 levels	
Item no.	Price in € (plus VAT)
PICD08LED2-I	2,508
PICD12LED2-I	2,965
PICD16LED2-I	3,406
PICD20LED2-I	4,279
PICD23LED2-I	4,932

REFRIGERATED DISPLAY COUNTERS

Enodis
CHILD



COLD
UNITS

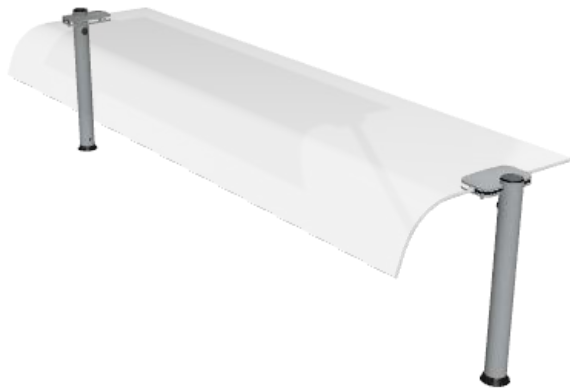

single display counter



double display counter

DESCRIPTION

Display counter with 6 mm curved glass on 1 side. Polished stainless steel 40 mm bar. Height 370 mm with 1 level and 640 mm with 2. 240 v single-phase power supply. Available as add-on: under-shelf LED lighting strip or single/double lighting strip for double shelves.

Refrigerated display counters - 1 level

Length	GN capacity	Lighting wattage (per shelf)	Single shelf	
		LED	Item no.	Price in € (plus VAT)
800*	2	8	PICS08	691
1,200*	3	14	PICS12	711
1,600	4	20	PICS16	726
2,000	5	26	PICS20	1,038
2,300	6	30	PICS23	1,060

Single shelf (for each shelf) + LED lighting	
Item no.	Price in € (plus VAT)
PICS08LED	1,078
PICS12LED	1,236
PICS16LED	1,451
PICS20LED	1,667
PICS23LED	1,759

* Display counters with length of 800 can be fitted to 800 and 900 units. Display counters with length of 1,200 can be fitted to 1,200 and 1,250 units.

Refrigerated display counters - 2 levels

Length	GN capacity	Lighting wattage**	Double shelf	
		LED	Item no.	Price in € (plus VAT)
800*	2	8	PICD08	1,047
1,200*	3	14	PICD12	1,164
1,600	4	20	PICD16	1,191
2,000	5	26	PICD20	1,551
2,300	6	30	PICD23	1,798

Double shelves + LED lighting 1 level	
Item no.	Price in € (plus VAT)
PICD08LED1	1,494
PICD12LED1	1,716
PICD16LED1	1,808
PICD20LED1	2,409
PICD23LED1	3,865

Double shelves + LED lighting 2 levels	
Item no.	Price in € (plus VAT)
PICD08LED2	1,792
PICD12LED2	1,859
PICD16LED2	2,049
PICD20LED2	2,529
PICD23LED2	2,787

** Per shelf

* Display counters with length of 800 can be fitted to 800 and 900 units. Display counters with length of 1,200 can be fitted to 1,200 and 1,250 units.

RECTANGULAR SALAD'BAR WITH STATIC OR VENTILATED COOLING

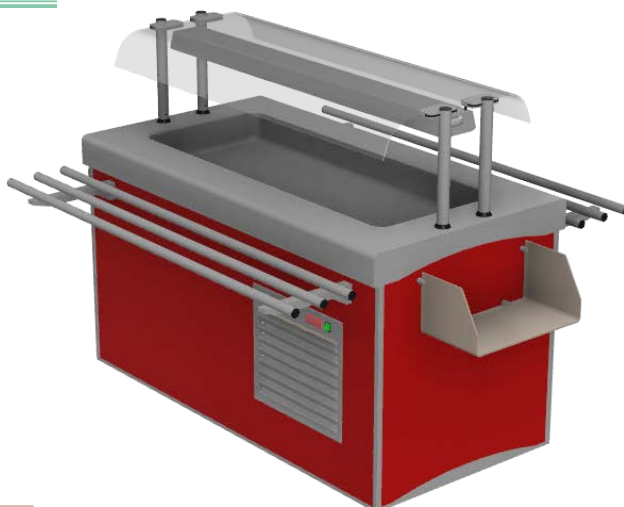
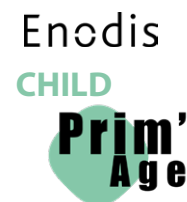

Available for hot counters, please ask us

DESCRIPTION

AISI 304 stainless steel structure. AISI 304 stainless steel top thickness 2 mm. Rounded edges. Laminate façade with 15 mm elevation. Includes 3-bar stainless steel handrail.

Recessed container, depth 30 mm or 110 mm, drains directly (3/4 draining). Static refrigeration using copper coiling located under the tank with HCFO foam insulation.

Ventilated tank, base in 2 depth-adjustable parts (30 to 110 mm), GN1/1 compatible (oscillating ventilated evaporator)

Noise level with refrigeration unit 56 dB(A). Comes with removable frame. Refrigerant R455A Touch-key controls.

Display counter with curved glass on both sides (6 mm) plus LED lighting as standard. 2 stainless steel sections on each side diameter 40 mm. Side shelves. Closed cabinet body to fit façade on 4 sides with refrigeration unit located at one end. Width: 1,470 mm with both handrails, height: 900 mm. 240 v single-phase power supply.

Available without refrigeration unit (comes with vacuum pump, control facility, pressure regulator and evaporator).

*Add SG to item number. Ex. SBSGRB16PRI. Condensate drip tray not included.

Salad'bar with static cooling - tank depth 30 mm

Item no.	Tank	Power (w)	Power (w)	Length	With refrigeration unit Price in € (plus VAT)	Without refrigeration unit* Price in € (plus VAT)
	Tray capacity	Electric	Cooling capacity (W)		Stainless steel top	Stainless steel top
SBRH16PRI	4 GN1/1	450	435	1,600	10,608	9,567
SBRH20PRI	5 GN1/1	700	580	2,000	11,985	10,877
SBRH23PRI	6 GN1/1	700	580	2,300	12,974	11,742

Ask us about our plan stone and granite tops.

Salad'bar with static cooling - tank depth 110 mm

Item no.	Tank	Length	With refrigeration unit Price € (plus VAT)	Without refrigeration unit* Price in € (plus VAT)
	Tray capacity		Stainless steel top	Stainless steel top
SBRB16PRI	3 GN1/1	1,600		
SBRB20PRI	5 GN1/1	2,000		
SBRB23PRI	6 GN1/1	2,300		

Ask us about our plan stone and granite tops.

Salad'bar with ventilated cooling - tank depth 30 to 110 mm

Item no.	Tank	Power (w)	Power (w)	Length	With refrigeration unit Price € (plus VAT)	Without refrigeration unit* Price in € (plus VAT)
	Tray capacity	Electric	Cooling capacity (W)		Stainless steel top	Stainless steel top
SBRV16PRI	4 GN1/1	450	435	1,600	19,456	18,667
SBRV20PRI	5 GN1/1	700	580	2,000	21,117	20,906
SBRV23PRI	6 GN1/1	700	580	2,300	23,111	22,083

Ask us about our plan stone and granite tops.

OCTAGONAL SALAD'BAR

Enodis
CHILD

Prim'
Age

COLD
UNITS

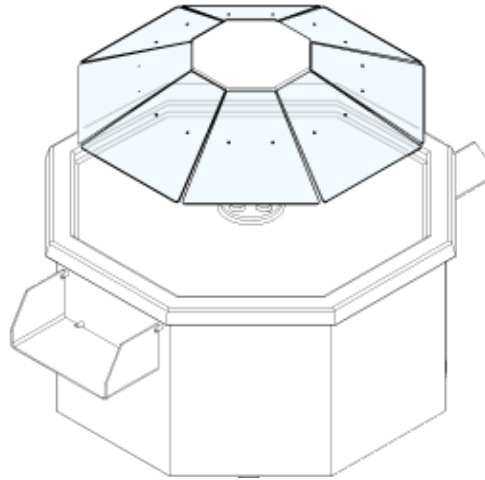

DESCRIPTION

AISI 304 stainless steel structure. AISI 304 stainless steel top thickness 2 mm. Rounded edges. Laminate façade with 15 mm elevation. Includes 3-bar stainless steel handrail. Central octagonal display and self-service island with upper structure, sneeze guard, LED lighting and methacrylate lateral plate holders. Recessed tank, depth 50 mm, drains directly (3/4 draining). Static refrigeration using copper coiling located under the tank with HCFO foam insulation. Touch-key controls. Noise level with refrigeration unit 56 dB(A). Comes with removable frame. Refrigerant R455A Trays slides featuring 3 smooth bars (brushed stainless steel) diameter 32 fitted to stainless steel brackets (height 800 mm). Closed cabinet body to fit façade on 8 sides with refrigeration unit located at one end. Dimensions: 1,400 x 1,400 mm or 1,700 x 1,700 mm. Power supply 240 v. Unit not available in granite.

Available without refrigeration unit (comes with vacuum pump, control facility, pressure regulator and evaporator).

*Add SG to item number. Ex. SBSGOCTO14PRI. Condensate drip tray not included.

Octagonal salad'bar with static cooling - tank depth 50 mm

Item no.	Power	Power	Length	With refrigeration unit	Without refrigeration unit*
	Electric	Cooling capacity (W)		Side	Price in € (plus VAT)
SBOCTO14PRI	700	753	1,400	20,844	19,593
SBOCTO18PRI	800	1,166	1,800	22,609	21,381

Ask us about our motorised display counter

OCTAGONAL SALAD'BAR ADD-ONS		
Item no.	Name	Price in € (plus VAT)
MOTOR	Motorised	Please ask us

“CRISTALINE” REFRIGERATED DISPLAY CABINETS ON OPEN CUPBOARD WITH 2 LEVELS, VENTILATED COOLING AND REAR AIRFLOW SYSTEM

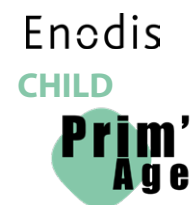

on open cupboard



tank depth 30 to 110 mm

DESCRIPTION

AISI 304 stainless steel structure. AISI 304 stainless steel top thickness 2 mm. Rounded front edge. Laminate façade with 15 mm elevation. Includes 3-bar stainless steel handrail. Ventilated tank, base in 2 depth-adjustable parts (30 to 110 mm), GN1/1 compatible (oscillating ventilated evaporator) Noise level with refrigeration unit 56 dB(A). Comes with removable frame. Refrigerant R455A HCFO foam insulation. Potentiometer for fan control to optimise operation and energy consumption. Adjustable control for the display cabinet. Touch-key controls.

Rectangular refrigerated display cabinet with rear ventilation. Customer side open with thermal curtain. Add-on: curved glass cover on hydraulic cylinders for easy lifting and cleaning. 2 sliding doors in double-walled Plexiglas with micro-perforations to allow laminar airflow with front suction to form the air curtain. 2 height-adjustable shelves. LED lighting. Operating temperature: 2°C/10°C. Condensate drip tray system included.

Power supply 240 v single-phase (except models with 2,600 length, which have 400 v 3-phase).

Child unit height: 1,360 mm.

Available without refrigeration unit (comes with vacuum pump, control facility, pressure regulator and evaporator). ex *VSGO2CL12PRI. Condensate drip tray not included.

“Cristaline” refrigerated display cabinets on open cupboard with 2 levels, ventilated cooling and rear airflow system

Item no.	Tank		Length	With refrigeration unit Price in € (plus VAT)		Without refrigeration unit* Price in € (plus VAT)	
	Tray capacity	Cooling capacity (w)		Stainless steel top		Stainless steel top	
VO2CL12PRI	3 GN1/1	900 / 1,166	1,250	16,137		15,137	
VO2CL16PRI	4 GN1/1	1,200 / 1,573	1,600	18,884		17,855	
VO2CL20PRI	5 GN1/1	1,400 / 1,717	2,000	20,087		19,043	

“CRISTALINE” REFRIGERATED DISPLAY CABINETS ON OPEN CUPBOARD WITH 3 LEVELS, VENTILATED COOLING AND REAR AIRFLOW SYSTEM

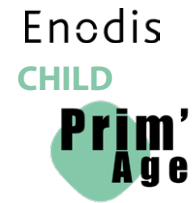

with refrigerated storage



tank depth 30 to 110 mm

DESCRIPTION

AISI 304 stainless steel structure. AISI 304 stainless steel top thickness 2 mm. Rounded front edge. Laminate façade with 15 mm elevation. Includes 3-bar stainless steel handrail. Ventilated tank, base in 2 depth-adjustable parts (30 to 110 mm), GN1/1 compatible (oscillating ventilated evaporator) HCFO foam insulation. Noise level with refrigeration unit 56 dB(A). Comes with removable frame. Refrigerant R455A. Potentiometer for fan control to optimise operation and energy consumption. Adjustable control for the display cabinet. Touch-key controls.

Rectangular refrigerated display cabinet with rear ventilation. Customer side open with thermal curtain. Add-on: curved glass cover on hydraulic cylinders for easy lifting and cleaning. 2 sliding doors in double-walled Plexiglas with micro-perforations to allow laminar airflow with front suction to form the air curtain. 3 height-adjustable shelves. LED lighting. Operating temperature: 2°C/10°C. Condensate drip tray system included.

Power supply 240 v single-phase (except models with 2,600 length, which have 400 v 3-phase). Child unit height: 1,560 mm.*Condensate drip tray not included.

“Cristaline” refrigerated display cabinets on open cupboard with 3 levels, ventilated cooling and rear airflow system

Item no.	Tank Tray capacity	Cooling capacity (w)	Length	With refrigeration unit Price in € (plus VAT)	Without refrigeration unit* Price in € (plus VAT)
				Stainless steel top	Stainless steel top
VO3CL12PRI	3 GN1/1	900 / 1,166	1,250	17,173	16,162
VO3CL16PRI	4 GN1/1	1,200 / 1,573	1,600	19,764	18,724
VO3CL20PRI	5 GN1/1	1,400 / 1,717	2,000	21,249	20,194

“ÉLÉGANCE” REFRIGERATED DISPLAY CABINETS ON OPEN CUPBOARD WITH 2 LEVELS, VENTILATED COOLING AND REAR AIRFLOW SYSTEM



on open cupboard



tank depth 30 to 110 mm

DESCRIPTION

AISI 304 stainless steel structure. AISI 304 stainless steel top thickness 2 mm. Rounded front edge. Laminate façade with 15 mm elevation. Includes 3-bar stainless steel handrail. Ventilated tank, base in 2 depth-adjustable parts (30 to 110 mm), GN1/1 compatible (oscillating ventilated evaporator) Noise level with refrigeration unit 56 dB(A). Comes with removable frame. Refrigerant R455A. HCFO foam insulation. Potentiometer for fan control to optimise operation and energy consumption. Adjustable control for the display cabinet. Touch-key controls.

Rounded refrigerated display cabinet with rear ventilation. Customer side open with thermal curtain. Curved glass cover on hydraulic cylinders for easy lifting and cleaning available as add-on. 2 sliding doors in double-walled Plexiglas with micro-perforations to allow laminar airflow with front suction to form the air curtain. 2 height-adjustable shelves. LED lighting. Operating temperature: 2°C/10°C. Condensate drip tray system included. 240 v single-phase power supply.

Child unit height: 1,350 mm.*Condensate drip tray not included.

“Élégance” refrigerated display cabinets on open cupboard with 2 levels, ventilated cooling and rear airflow system

Item no.	Tank			With refrigeration unit Price in € (plus VAT)		Without refrigeration unit* Price in € (plus VAT)	
	Tray capacity	Cooling capacity (w)	Length	Stainless steel top		Stainless steel top	
VO2AL09PRI	2 GN1/1	800 / 972	950	14,045		13,203	
VO2AL12PRI	3 GN1/1	900 / 1,166	1,250	15,233		14,320	
VO2AL16PRI	4 GN1/1	1,200 / 1,573	1,600	16,740		15,736	
VO2AL20PRI	5 GN1/1	1,400 / 1,717	2,000	17,721		16,658	

“ÉLÉGANCE” REFRIGERATED DISPLAY CABINETS ON OPEN CUPBOARD WITH 3 LEVELS, VENTILATED COOLING AND REAR AIRFLOW SYSTEM

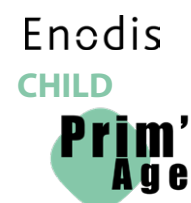

on open cupboard



tank depth 30 to 110 mm

DESCRIPTION

AISI 304 stainless steel structure. AISI 304 stainless steel top thickness 2 mm. Rounded front edge. Laminate façade with 15 mm elevation. Includes 3-bar stainless steel handrail. Ventilated tank, base in 2 depth-adjustable parts (30 to 110 mm), GN1/1 compatible (oscillating ventilated evaporator) Noise level with refrigeration unit 56 dB(A). Comes with removable frame. Refrigerant R455A. Potentiometer for fan control to optimise operation and energy consumption. HCFO foam insulation. Adjustable control for the display cabinet. Touch-key controls.

Rounded refrigerated display cabinet with rear ventilation. Customer side open with thermal curtain. Curved glass cover on hydraulic cylinders for easy lifting and cleaning available as add-on. 2 sliding doors in double-walled Plexiglas with micro-perforations to allow laminar airflow with front suction to form the air curtain. 3 height-adjustable shelves. LED lighting. Operating temperature: 2°C/10°C. Condensate drip tray system included.

240 v single-phase power supply.

Child unit height overall dimensions: 1,550 mm.*Condensate drip tray not included.

“Élégance” refrigerated display cabinets on open cupboard with 3 levels, ventilated cooling and rear airflow system

Item no.	Tank	Cooling capacity (w)	Length	With refrigeration unit Price in € (plus VAT)
	Tray capacity			Stainless steel top
VO3AL09PRI	2 GN1/1	800 / 972	950	16,071
VO3AL12PRI	3 GN1/1	900 / 1,166	1,250	16,485
VO3AL16PRI	4 GN1/1	1,200 / 1,573	1,600	17,836
VO3AL20PRI	5 GN1/1	1,400 / 1,717	2,000	19,094

Without refrigeration unit* Price in € (plus VAT)
Stainless steel top
15,107
15,496
16,766
17,949

“CLASSIQUE” REFRIGERATED DISPLAY CABINETS ON OPEN CUPBOARD WITH STATIC COOLING

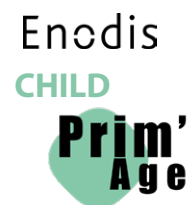

on open cupboard



container depth 30 mm

DESCRIPTION

AISI 304 stainless steel structure. AISI 304 stainless steel top thickness 2 mm. Rounded front edge. Laminate façade with 15 mm elevation. Includes 3-bar stainless steel handrail. Recessed tank, depth 30 mm. Static refrigeration using copper coiling located under the tank with HCFO foam insulation. Noise level with refrigeration unit 56 dB(A). Comes with removable frame. Refrigerant R455A Dual adjustable control (display cabinet and tank). Touch-key controls. Glass display cabinet has insulated box and ventilated evaporator. Front-flow refrigeration and rear air return. Tempered glass sliding doors on service side and roller blind for fridge on customer side. Tempered double glazing on both sides. LED lighting on customer side. Condensate drip tray system included. 240 v single-phase power supply. Child unit height: 1660 mm.*Condensate drip tray not included.

“Classique” display cabinets - static tank on open cupboard - for starters/desserts

Item no.	Tank Tray capacity	Cooling capacity (w)	Power (w)	Length	With refrigeration unit Price in € (plus VAT)	Without refrigeration unit* Price in € (plus VAT)
					Stainless steel top	Stainless steel top
VHOL12PRI	3 GN1/1	1,543	1,200	1,200 / 1,250*	18,042	17,019
VHOL16PRI	4 GN1/1	2,135	1,650	1,600	20,808	19,757
VHOL20PRI	5 GN1/1	2,470	2,100	2,000	22,260	21,194
VHOL23PRI	6 GN1/1	2,664	2,300	2,300	23,696	22,617

“CLASSIQUE” REFRIGERATED DISPLAY CABINETS ON OPEN CUPBOARD WITH STATIC COOLING AND REFRIGERATED STORAGE

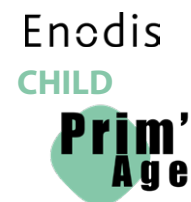

with storage (1 door)



container depth 30 mm

DESCRIPTION

AISI 304 stainless steel structure. AISI 304 stainless steel top thickness 2 mm. Rounded front edge. Laminate façade with 15 mm elevation. Includes 3-bar stainless steel handrail. Recessed tank, depth 30 mm. Static refrigeration using copper coiling located under the tank with HCFO foam insulation. Noise level with refrigeration unit 56 dB(A). Comes with removable frame. Refrigerant R455A. Triple adjustable control (tank and storage area). Touch-key controls. Glass display cabinet has insulated box and ventilated evaporator. Front-flow refrigeration and rear air return. Tempered glass sliding doors on service side and roller blind for fridge on customer side. Tempered double glazing on both sides. LED lighting on customer side. Condensate drip tray system included. Units with refrigerated storage: stainless steel door(s) with removable lip seal. With 5 grids for GN1/1 or GN2/1 trays (not included). 240 v single-phase power supply. Child unit height: 1,660 mm.*Condensate drip tray not included.

“Classique” display cabinets - static tank with refrigerated storage - for starters/desserts

Item no.	Tank	Refrigerated storage	Power (w)	Power (w)	Length	With refrigeration unit	Without refrigeration unit*
	Tray capacity		Electric	Cooling capacity (W)		Price in € (plus VAT)	
						Stainless steel top	Stainless steel top
VHOR14PRI	3 GN 1/1	1 x GN1/1 door	1,200	1,543	1,400	20,547	19,501
VHOR16PRI	4 GN 1/1	1 x GN2/1 door	1,700	2,135	1,600	23,282	22,206
VHOR20PRI	5 x GN 1/1	1 x GN2/1 door	1,900	2,470	2,000	25,623	24,542
VHOR23PRI	6 x GN 1/1	2 x GN2/1 doors	2,100	2,664	2,300	28,021	26,897

COLD UNITS - ADD-ONS

ADD-ONS FOR REFRIGERATED UNITS		
Item no.	Name	Price in € (plus VAT)
CEPO	Laminate end panel (per unit)	490
AGC	Air vent on customer side via opening in the laminate	870
RPP412I	Set of 4 stainless steel wheels diameter 125 mm (2 with brakes) for < 2,000 mm unit	316
PCN220	16A power socket not protected/connected (per unit)	167
PCA	Arnoul socket (per unit)	338
PCTri	Tri-phase socket (per unit)	281
FCPORTREFRI	Lock with key for refrigerated door (one for each door)	105
TBCAV	Front control panel	393
TBCD	Right-side customer-facing control panel	393
TBCG	Left-side customer-facing control panel	393
ALH	Power supply via the top from a cabinet (maximum bar height 3000 mm with mobile stainless steel plate to be fixed to the ceiling)	469
BIPR	Protective stainless steel strip (between counter top and tray slide) for reconstituted stone or granite top and rail (per LM)	170
HSPERPI	Special tray slide height (815 mm to 830 mm elevation) per unit	294
TDSB	Smoked Plexiglas plate shelf	356
BSC	Tank separator bar	62
GTROP	Tropicalised system	951
REGETF	Additional charge for EasyTouch controls on cold unit with USB socket and dynamic lighting	784

COLD UNITS - ADD-ONS



ADD-ONS FOR REFRIGERATED UNITS		
Item no.	Name	Price in € (plus VAT)
PVHP530	Additional charge for display counter height 530 mm	171
MVBE1	Deduction when purchased without drip trays for open cupboard drinks display unit, unit with 1-door & storage, or item number HO.	-211
MVBE2	Deduction when purchased without drip trays for drinks display unit with 2 doors and item number HO.	-421
MVBE3	Deduction when purchased without drip trays for open cupboard display cabinet on open cupboard	-437
MVBE4	Deduction when purchased without drip trays for display cabinet with refrigerated storage	-647
EMB10	Lower shelf for unit on open cupboard for unit length 950 mm	312
EMB12	Lower shelf for unit on open cupboard for unit length 1,200 mm	338
EMB13	Lower shelf for unit on open cupboard for unit length 1,350 mm	381
EMB16	Lower shelf for unit on open cupboard for unit length 1,600 mm	396
EMB17	Lower shelf for unit on open cupboard for unit length 1,700 mm	471
EMB20	Lower shelf for unit on open cupboard for unit length 2,000 mm	489
EMB23	Lower shelf for unit on open cupboard for unit length 2,300 mm	561
EMB26	Lower shelf for unit on open cupboard for unit length 2,600 mm	393
PVDV	Additional charge for vibrated top (per LM)	393
BPM	Mirror polished front edge (per LM)	162

ADD-ONS FOR DISPLAY CABINETS		
Item no.	Name	Price in € (plus VAT)
AGSG	Replace glass shelves with guide rails	Please ask us

COLD UNITS - ADD-ONS

RIGID NIGHT CURTAIN ADD-ONS WITH LOCK AND KEY FOR "CRISTALINE" DISPLAY CABINETS		
Item no.	Name	Price in € (plus VAT)
RDNFC2	"Cristaline" glass display units 2GN	1,556
RDNFC3	"Cristaline" glass display units 3GN	1,738
RDNFC4	"Cristaline" glass display units 4GN	1,958
RDNFC5	"Cristaline" glass display units 5GN	2,125
RDNFC6	"Cristaline" glass display units 6GN	2,371
RDNFC7	"Cristaline" glass display units 7GN	2,556

FRIDGE CURTAIN ADD-ONS (SERVICE SIDE) FOR CLASSIQUE DISPLAY CABINETS (INSTEAD OF SLIDING GLASS DOORS)		
Item no.	Name	Price in € (plus VAT)
RTVC3	"Classique" display cabinet 3GN1/1, 1,200 mm	401
RTVC4	"Classique" display cabinet 4GN1/1, 1,600 mm	498
RTVC5	"Classique" display cabinet 5GN1/1, 2,000 mm	585
RTVC6	"Classique" display cabinet 6GN1/1, 2,300 mm	712



03

HEATED UNITS

Technical Information

- **All AISI 304 (18-10) stainless steel** construction .
- AISI 304 stainless steel **top thickness 2 mm** with 220 grain satin polish (**scotch-brite**).
Customer side counter surface profile 20 mm rounded edge with **110 mm drop**.
Service side counter surface straight edge with **60 mm drop**.
Available as add-on: granite or reconstituted stone top thickness 30 mm (one piece per unit). Granite or reconstituted stone top finished with straight edge on service side and end and rounded edge on customer side.
- Depth 830 mm, **height 900 mm (for safety reasons)** on stainless steel base height 180 mm adjustable -25/+50 mm.
- Units must be bolted at front and rear with sealant between **clean edge** panelling.
- Tray slide brackets in AISI 304 stainless steel fitted to frame through laminated front to ensure tray slide is fully aligned.
- **Standard stainless steel tray rail 3 profiled bars diameter 32 mm (included in unit price)**.
Available as add-on: granite rail, reconstituted stone rail, glass rail or laminate rail.
- Customer side **façade** as standard in **water-repellent melamine** coated in double-sided laminate **thickness 20 mm. 15 mm elevation** with lower stainless steel corner guard.
Available on request: 180 mm to 15 mm façade elevation with lower stainless steel corner guard.
Panels are fitted with an interlocking clip system and held in place by brackets.
Service side fascia panel attached with easily removable screws for access.
- **250 colours** to choose from our colour chart.

Specifications

- **Ventilated air-heated tank with welded rounded corners** and self-adhesive 1.8 mm stainless steel armoured fin heaters on the underside of the tank with axial fans. Maximum tray depth 150 mm. Temperature range 65°C to 105°C
- **Ventilated air-heated tank with welded rounded corners** and diamond pattern toward 3/4" drain plug. With self-adhesive 1.8 mm stainless steel armoured fin heaters on the underside of the tank. Maximum tray depth 150 mm. Temperature range 65°C to 85°C.
Tank fill automatically stops when full. 2 water level detection probes (min. and max. levels).
- **Top heated by black tempered glass-ceramic panels**, thickness 6 mm GN1/1 (505 x 325 mm). Temperature range 65°C to 105°C.
- **Ventilated chamber** with rock wool insulation. Temperature range 0°C to 85°C. Sliding doors with rock wool insulation. Power 230 V single-phase or 400 v 3-phase, Neutral and Earth.
- **Display counters**
Loose or with heating or lighting
High quality ceramic heating ramp, power 150 W/lamp with variothermal insulation.

Complies with AFNOR standard AC D 40-004 (the French industrial standards authority).

Our most **Enodis** **CHILD** **Prim'Age**

POPULAR PRODUCTS

Display counters

Polished stainless steel bar diameter 40 mm
Tempered glass shelf with curved sneeze guard
thickness 6 mm.
LED lighting and ceramic heating ramp (separate
controls) for models with heating/lighting.
Vertical pane for bain-marie display counters.

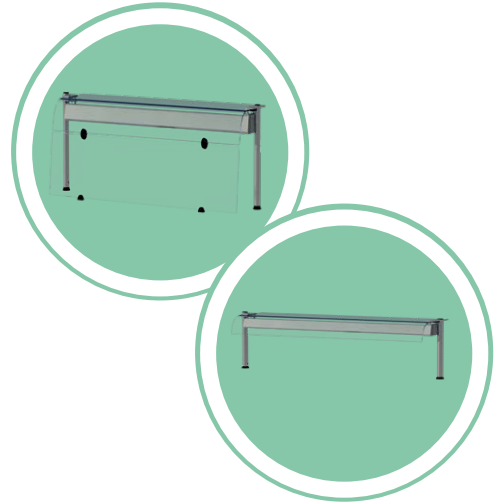

“Cristaline” hot glass display units

Rectangular heated display cabinet.
Temperature-holding surface made of GN1/1 black
tempered glass panels.
1 or 2 heated shelves (depending on model).
Stainless steel elements underneath.
Temperature control 65°C to 105°C.
LED lighting.
2 sliding Plexiglass doors.

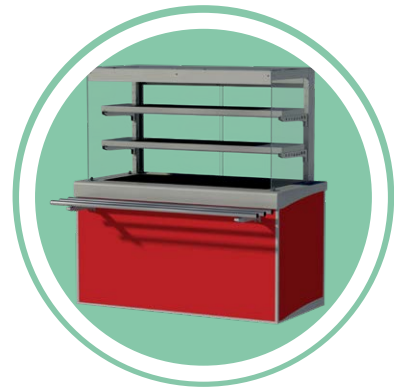

“Élégance” heated display cabinets

Round heated display cabinet.
Temperature-holding surface made of GN1/1 black
tempered glass panels.
1 or 2 heated shelves (depending on model).
Stainless steel elements underneath.
Temperature control 65°C to 105°C.
LED lighting.
2 sliding Plexiglass doors.

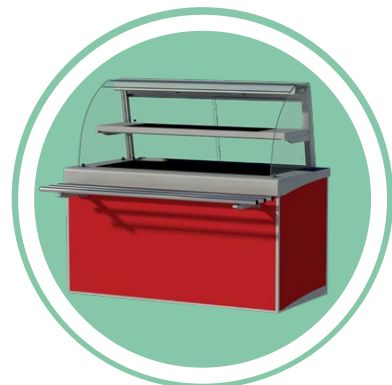



HEATED
UNITS

GLASS DISPLAY COUNTERS 1 LEVEL

Enodis
CHILD

Prim'
Age

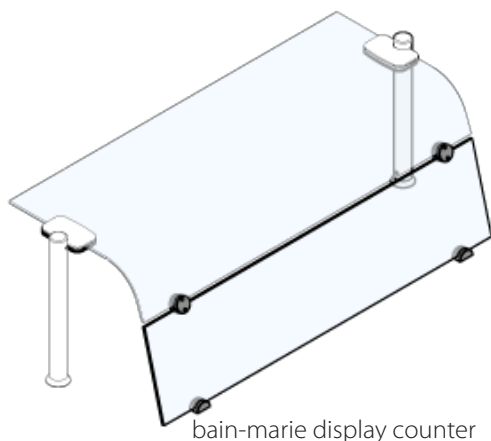

bain-marie display counter

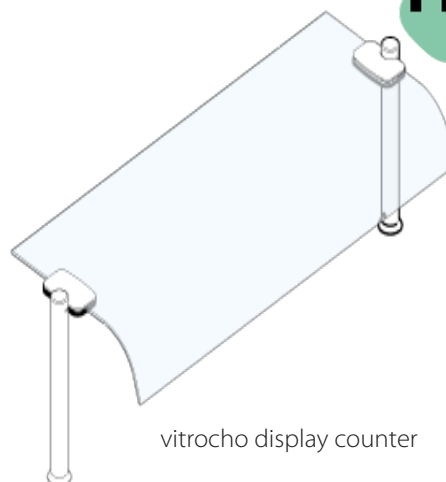

vitrocho display counter

DESCRIPTION

Bain-marie display counter with tempered curved glass 6 mm. Polished stainless steel bars diameter 40 mm. Height 385 mm. Vertical guard in white tempered glass 6 mm.
Available as add-on: ceramic heating ramp + LED lighting under single shelf. LED lighting. 240 v single-phase power supply. Vibrated and polished.

Bain-marie display counters

Single shelf			Single shelf + LED lighting + heating		
Tank	Item no.	Price in € (plus VAT)	Item no.	Power (w) LED lighting + heating	Price in € (plus VAT)
2 GN1/1	TDSB08	739	TDSB08CLED	8 + 150	1,564
3 GN1/1	TDSB12	776	TDSB12CLED	14 + 300	1,638
4 GN1/1	TDSB16	886	TDSB16CLED	20 + 300	1,844
5 GN1/1	TDSB20	1,034	TDSB20CLED	26 + 450	2,318
6 GN1/1	TDSB23	1,179	TDSB23CLED	30 + 450	2,748

DESCRIPTION

Vitrocho display counter: single tempered curved glass shelf 6 mm. Polished stainless steel bar diameter 40 mm. Height 385 mm.
Available as add-on: ceramic heating ramp + LED lighting under single shelf. LED lighting. 240 v single-phase power supply. Vibrated and polished.

Vitrocho surface display counters

Single shelf			Single shelf + LED lighting + heating		
Tank	Item no.	Price in € (plus VAT)	Item no.	Power (w) LED lighting + heating	Price in € (plus VAT)
2 GN1/1	TDSV08	696	TDSV08CLED	8 + 150	1,522
3 GN1/1	TDSV12	733	TDSV12CLED	14 + 300	1,612
4 GN1/1	TDSV16	772	TDSV16CLED	20 + 300	1,905
5 GN1/1	TDSV20	1,070	TDSV20CLED	26 + 450	2,243
6 GN1/1	TDSV23	1,093	TDSV23CLED	30 + 450	2,604

DISPLAY COUNTER ADD-ONS

Item no.	Name	Price in € (plus VAT)
PVHP530	Additional charge for display counter height 530 mm	171

GLASS DISPLAY COUNTERS WITH STAINLESS STEEL TOP 1 LEVEL

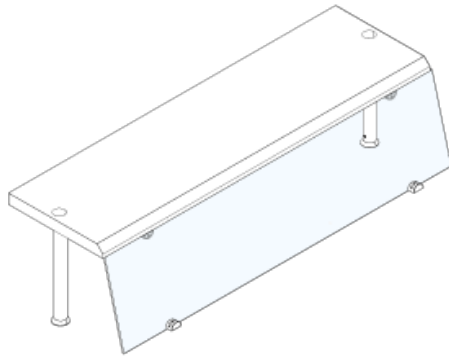
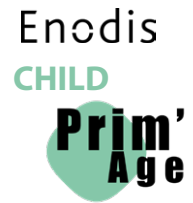

display counter 1 level

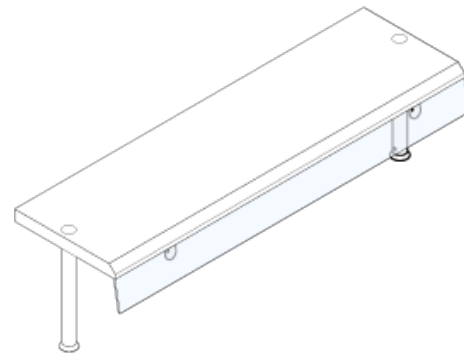

display counter 1 level

DESCRIPTION

1.8 mm stainless steel display counters with straight glass sneeze guard in 6 mm white tempered glass. Polished stainless steel bars diameter 40 mm. Height 370 mm with 1 level and 640 mm with 2. 240 v single-phase power supply. Available as add-on: one or two under-shelf LED lighting strips for first and/or second shelf.

Stainless steel display counters with front-closing sneeze guard - 1 level

Length	GN capacity	Single shelf		Single shelf (for each shelf) + LED lighting		
		Item no.	Price in € (plus VAT)	Item no.	LED lighting wattage (per shelf)	Price in € (plus VAT)
800	2	TDSB08-I	1,170	TDSB08LED-I	8	1,855
1,200	3	TDSB12-I	1,270	TDSB12LED-I	14	2,040
1,600	4	TDSB16-I	1,372	TDSB16LED-I	20	2,075
2,000	5	TDSB20-I	1,749	TDSB20LED-I	26	2,865
2,300	6	TDSB23-I	1,955	TDSB23LED-I	30	3,390

Stainless steel & glass display counters - 1 level

Length	GN capacity	Single shelf		Single shelf (for each shelf) + LED lighting		
		Item no.	Price in € (plus VAT)	Item no.	LED lighting wattage (per shelf)	Price in € (plus VAT)
800	2	TDSV08-I	1,053	TDSV08LED-I	8	1,742
1,200	3	TDSV12-I	1,170	TDSV12LED-I	14	1,942
1,600	4	TDSV16-I	1,285	TDSV16LED-I	20	2,188
2,000	5	TDSV20-I	1,634	TDSV20LED-I	26	2,800
2,300	6	TDSV23-I	1,793	TDSV23LED-I	30	3,240

2 LEVEL GLASS DISPLAY COUNTERS WITH SNEEZE GUARD



display counter 2 levels

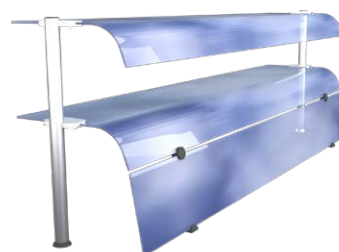

display counter 2 levels

DESCRIPTION

1.8 mm stainless steel display counters with straight glass sneeze guard in 6 mm white tempered glass. Polished stainless steel bars diameter 40 mm. Height 370 mm with 1 level and 640 mm with 2. 240 v single-phase power supply. Available as add-on: one or two under-shelf LED lighting strips for first and/or second shelf.

Glass display counters with sneeze guard - 2 levels

Length	GN capacity	Lighting wattage LED	Double shelf		Double shelves + LED lighting 1 level		Double shelves + LED lighting 2 levels	
			Item no.	Price in € (plus VAT)	Item no.	Price in € (plus VAT)	Item no.	Price in € (plus VAT)
800	2	8	PICD08	1,129	PICD08LED1	1,560	PICD08LED2	1,991
1,200	3	14	PICD12	1,266	PICD12LED1	1,832	PICD12LED2	2,398
1,600	4	20	PICD16	1,397	PICD16LED1	2,090	PICD16LED2	2,783
2,000	5	26	PICD20	1,781	PICD20LED1	2,640	PICD20LED2	3,499
2,300	6	30	PICD23	1,998	PICD23LED1	3,015	PICD23LED2	4,032

Glass display counters with sneeze guard - 2 front-closing levels

Length	GN capacity	Lighting wattage LED	Double shelf		Double shelves + LED lighting 1 level		Double shelves + LED lighting 2 levels	
			Item no.	Price in € (plus VAT)	Item no.	Price in € (plus VAT)	Item no.	Price in € (plus VAT)
800	2	8	PICDFD08	1,198	PICDFD08LED1	1,629	PICDFD08LED2	2,062
1,200	3	14	PICDFD12	1,339	PICDFD12LED1	1,905	PICDFD12LED2	2,471
1,600	4	20	PICDFD16	1,484	PICDFD16LED1	2,177	PICDFD016LED2	2,870
2,000	5	26	PICDFD20	1,946	PICDFD20LED1	2,805	PICDFD20LED2	3,664
2,300	6	30	PICDFD23	2,131	PICDFD23LED1	3,148	PICDFD23LED2	4,165

2 LEVEL DISPLAY COUNTERS IN STAINLESS STEEL WITH SNEEZE GUARD

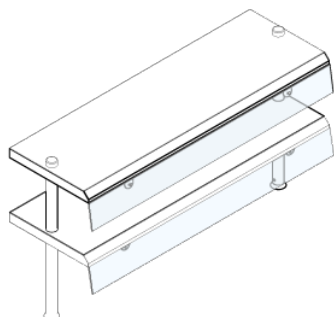

display counter 2 levels

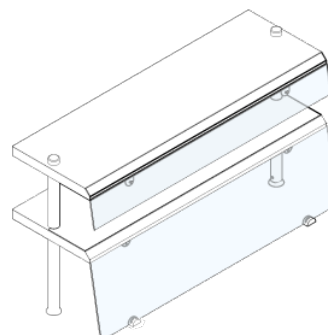

display counter 2 levels

DESCRIPTION

1.8 mm stainless steel display counters with straight glass sneeze guard in 6 mm white tempered glass. Polished stainless steel bars diameter 40 mm. Height 370 mm with 1 level and 640 mm with 2. 240 v single-phase power supply. Available as add-on: one or two under-shelf LED lighting strips for first and/or second shelf.

HEATED UNITS

Stainless steel display counters with sneeze guard - 2 levels

Length	GN capacity	Lighting wattage	Double shelf		Double shelves + LED lighting 1 level		Double shelves + LED lighting 2 levels	
		LED	Item no.	Price in € (plus VAT)	Item no.	Price in € (plus VAT)	Item no.	Price in € (plus VAT)
800	2	8	PIDD08-I	1,534	PIDD08LED1-I	1,965	PIDD08LED2-I	2,395
1,200	3	14	PIDD12-I	1,698	PIDD12LED1-I	2,264	PIDD12LED2-I	2,830
1,600	4	20	PIDD16-I	1,865	PIDD16LED1-I	2,558	PIDD16LED2-I	3,251
2,000	5	26	PIDD20-I	2,368	PIDD20LED1-I	3,227	PIDD20LED2-I	4,085
2,300	6	30	PIDD23-I	2,674	PIDD23LED1-I	3,691	PIDD23LED2-I	4,707

Stainless steel display counters with sneeze guard - 2 front-closing levels

Length	GN capacity	Lighting wattage	Double shelf		Double shelves + LED lighting 1 level		Double shelves + LED lighting 2 levels	
		LED	Item no.	Price in € (plus VAT)	Item no.	Price in € (plus VAT)	Item no.	Price in € (plus VAT)
800	2	8	TDFD08-I	1,592	TDFD08LED1-I	2,023	TDFD08LED2-I	2,454
1,200	3	14	TDFD12-I	1,771	TDFD12LED1-I	2,337	TDFD12LED2-I	2,903
1,600	4	20	TDFD16-I	1,937	TDFD16LED1-I	2,629	TDFD16LED2-I	3,322
2,000	5	26	TDFD20-I	2,554	TDFD20LED1-I	3,412	TDFD20LED2-I	4,270
2,300	6	30	TDFD23-I	2,802	TDFD23LED1-I	3,619	TDFD23LED2-I	4,836

“CRISTALINE” HEATED DISPLAY CABINETS, 1 LEVEL ON OPEN CUPBOARD OR WITH HEATED CHAMBER



DESCRIPTION

AISI 304 stainless steel structure. AISI 304 stainless steel top thickness 2 mm. Rounded front edge. Laminate exterior. 15 mm elevation. Includes 3 stainless steel handrails. Rectangular heated display cabinet. Temperature-holding surface and shelf made of GN1/1 black tempered glass panels heated underneath by adhesive elements. Ultra temperature uniformity at 90°C. Open on customer side. Straight glass cover on hydraulic cylinders for easy lifting and cleaning available as add-on. Power 400 v 3-phase. 2 sliding Plexiglass doors. LED lighting. Touch-key controls.

Child unit height overall dimensions: 1,360 mm.

“Cristaline” heated display cabinets, on open cupboard or with heated chamber - 1 level

Trays		Unit on open cupboard		
Tray capacity	Item no.	Power (w)	Length	Price in € (plus VAT)
2 GN1/1	VCO1CL09ES	1,490	950	13,274
3 GN1/1	VCO1CL12ES	2,350	1,250	14,383
4 GN1/1	VCO1CL16ES	2,780	1,600	16,140
5 GN1/1	VCO1CL20ES	3,740	2,000	18,078
6 GN1/1	VCO1CL23ES	4,700	2,300	22,983
7 GN1/1	VCO1CL26ES	5,330	2,600	26,513

Unit with heated chamber			
Item no.	Power (w)	Length	Price in € (plus VAT)
VCO1CE09ES	3,090	950	15,641
VCO1CE12ES	3,950	1,250	16,975
VCO1CE16ES	4,380	1,600	19,004
VCO1CE20ES	5,340	2,000	21,237
VCO1CE23ES	6,300	2,300	25,223
VCO1CE26ES	8,530	2,600	31,660

“CRISTALINE” HEATED DISPLAY CABINETS, 2 LEVELS ON OPEN CUPBOARD OR WITH HEATED CHAMBER



DESCRIPTION

AISI 304 stainless steel structure. AISI 304 stainless steel top thickness 2 mm. Rounded front edge. Laminate exterior. 15 mm elevation. Includes 3 stainless steel handrails. Rectangular heated display cabinet. Temperature-holding surface and 2 shelves made of GN1/1 black tempered glass panels heated underneath by adhesive elements. Ultra temperature uniformity at 90°C. Open on customer side. Straight glass cover on hydraulic cylinders for easy lifting and cleaning available as add-on. Power Tri400 v. 2 sliding Plexiglass doors. LED lighting. Touch-key controls.

Child unit height overall dimensions: 1,560 mm.

“Cristaline” heated display cabinets, on open cupboard or with heated chamber - 2 levels

Trays		Unit on open cupboard		
Tray capacity	Item no.	Power (w)	Length	Price in € (plus VAT)
2 GN1/1	VCO2CL09ES	2,020	950	15,573
3 GN1/1	VCO2CL12ES	3,310	1,250	17,175
4 GN1/1	VCO2CL16ES	3,740	1,600	19,349
5 GN1/1	VCO2CL20ES	5,180	2,000	21,685
6 GN1/1	VCO2CL23ES	6,620	2,300	25,413
7 GN1/1	VCO2CL26ES	7,250	2,600	28,402

Unit with heated chamber			
Item no.	Power (w)	Length	Price in € (plus VAT)
VCO2CE09ES	3,620	950	17,941
VCO2CE12ES	4,910	1,250	19,766
VCO2CE16ES	5,340	1,600	22,216
VCO2CE20ES	8,380	2,000	24,844
VCO2CE23ES	9,820	2,300	27,910
VCO2CE26ES	10,450	2,600	33,554

HEATED UNITS - ADD-ONS

Enodis
CHILD



COMPATIBLE ADD-ONS FOR HEATED UNITS		
Item no.	Name	Price in € (plus VAT)
EMB08	Lower shelf for unit on open cupboard or intermediate shelf for heated chamber for unit length 800 mm	292
EMB09	Lower shelf for unit on open cupboard for unit length 950 mm	328
EMB12	Lower shelf for unit on open cupboard or intermediate shelf for heated chamber for unit length 1,200 mm	338
EMB16	Lower shelf for unit on open cupboard or intermediate shelf for heated chamber for unit length 1,600 mm	396
EMB20	Lower shelf for unit on open cupboard or intermediate shelf for heated chamber for unit length 2,000 mm	489
EMB23	Lower shelf for unit on open cupboard or intermediate shelf for heated chamber for unit length 2,300 mm	561
PVDV	Additional charge for vibrated top (per LM)	393
BPM	Mirror polished front edge (per LM)	162
CEPO	Laminate end panel (per unit)	490
MRGE800	1 x GN1/1 guide rail frame for heated chamber (entrance 325 mm) for unit length 800 mm	422
MRGE1200	2 x GN1/1 guide rail frames for heated chamber (entrance 325 mm) for unit length 1,200 mm	875
MRGE1600	2 x GN1/1 guide rail frames for heated chamber (entrance 325 mm) for unit length 1,600 mm	919
MRGE2000	2 x GN1/1 guide rail frames for heated chamber (entrance 530 mm) for unit length 2,000 mm	974
MRGE2300	2 x GN1/1 guide rail frames for heated chamber (entrance 530 mm) for unit length 2,300 mm	974
RPP412I	Set of 4 stainless steel wheels diameter 125 mm (2 with brakes)	316
PCN220	16A power socket not protected/connected (per unit)	167
PCA	Arnould socket (per unit)	338
PCTri	Tri-phase socket (per unit)	291
TBCAV	Front control panel	393
TBCD	Right-side customer-facing control panel	393
TBCG	Left-side customer-facing control panel	393
ALH	Power supply via the top from a cabinet (maximum bar height 3,000 mm with mobile stainless steel plate to be fixed to the ceiling)	469
VOLTSM	Single-phase voltage instead of 3-phase	please ask us
BIPR	Protective stainless steel strip (between counter top and tray slide) (per LM)	170
HSPERPI	Special tray slide height (815 mm to 830 mm elevation) (per cabinet)	294
REGETC	Additional charge for EasyTouch controls on cold unit with USB socket and dynamic lighting	669

HEATED UNITS - ADD-ONS

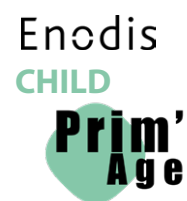

ADD-ONS FOR VITROCHO UNIT ON OPEN CUPBOARD WITH SHELF		
Item no.	Name	Price in € (plus VAT)
SBI06	Stainless steel* holder for GN1/1-65 gastro tray	205
SBI10	Stainless steel* holder for GN1/1-100 gastro tray	206
PDV60	60 mm recess for top with vitro plate (additional charge). Other recess dimensions are available on request	645
PDV60-3F	60 mm recess for vitro plate on 3 sides	2,606

DISPLAY COUNTER ADD-ONS		
Item no.	Name	Price in € (plus VAT)
PVHP530	Additional charge for display counter height 530 mm	171

HEATED UNITS

04

AUXILIARY UNITS

Technical Information

- **All AISI 304 (18-10) stainless steel** construction .
- AISI 304 stainless steel **top thickness 2 mm** with 220 grain satin polish (**scotch-brite**).
Customer side counter surface profile 20 mm rounded edge with **110 mm drop**.
Service side counter surface straight edge with **60 mm drop**.
Available as add-on: granite or reconstituted stone top thickness 30 mm (one piece per unit).
Granite or reconstituted stone top finished with straight edge on service side and end and rounded edge on customer side.
- Depth 830 mm, height 750 mm on stainless steel base height 180 mm adjustable -25/+50 mm.
- Units must be bolted at front and rear with sealant between **clean edge** panelling.
- Tray slide brackets in AISI 304 stainless steel fitted to frame through laminated front to ensure tray slide is fully aligned.
- **Standard stainless steel tray rail 3 profiled bars diameter 32 mm (included in unit price)**.
Available as add-on: granite rail, reconstituted stone rail, glass rail or laminate rail.
- Customer side **façade** as standard in **water-repellent melamine** coated in double-sided laminate **thickness 20 mm. 15 mm elevation** with lower stainless steel corner guard.
Available on request: 180 mm to 15 mm façade elevation with lower stainless steel corner guard.
Panels are fitted with an interlocking clip system and held in place by brackets.
Service side fascia panel attached with easily removable screws for access.
- **250 colours** to choose from our colour chart.

Our most **Enodis** **CHILD** **Prim'Age** **POPULAR PRODUCTS**

Loose units

Storage unit on open cupboard or open with adjustable floor and shelf, or with sliding doors (note: 800 mm unit comes with swing door).

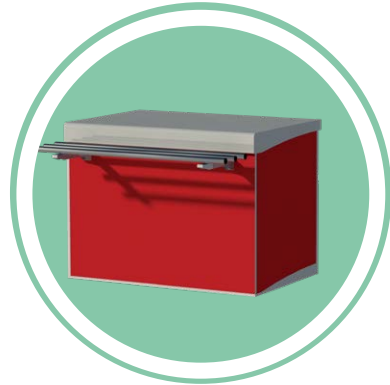

Corner units

Internal corner units: Open with floor and adjustable shelf on service side. External corner units: Laminate façade and rail on customer side.

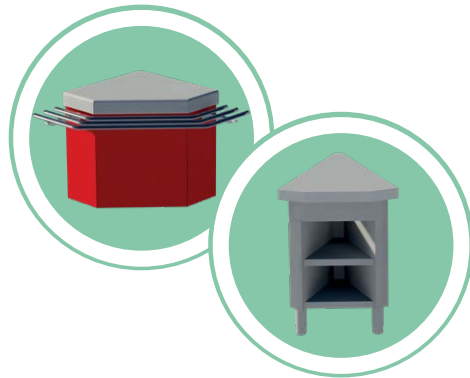

Utensil dispensers

Constant output glass dispensers. Capacity: 6 to 10 baskets (500 x 500).

Constant output hot plate storage and dispensers. Capacity: 110 plates. Power: 110 W.

Constant output tray dispensers. Capacity: 110 trays.

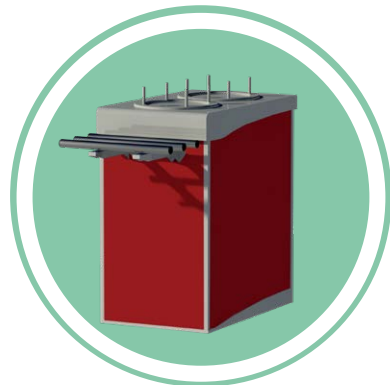

Trolley storage unit

AISI 304 stainless steel thickness 2 mm. Rounded front edge. Laminate façade with 15 mm elevation.

Stainless steel tray slide comes with 3 bars.

U-shaped version available for single trolley or E-shaped for 2).

Trolleys not included.

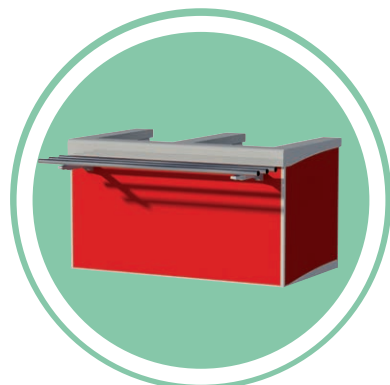

Our most

Enodis
CHILD
Prim'Age

POPULAR PRODUCTS

Queue barriers

Made from 40 mm brushed stainless bars with stainless steel fixing plate.
Height: 900 mm.

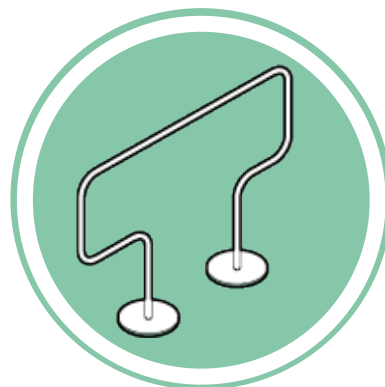

Front elements

A connecting element can be used to join two units to modify your configuration or it can be used as trolley storage.

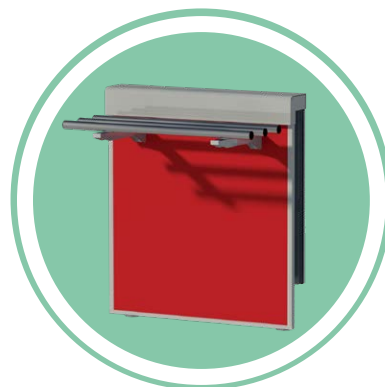

Trays slides

Standard: separate tray slide for each unit consisting of 3 brushed stainless steel bars diameter 32 mounted on stainless steel brackets.

Tray slide also available in stained beech wood, granite (thickness 30 mm), tempered glass or laminate (with 2 stainless steel slide bars).

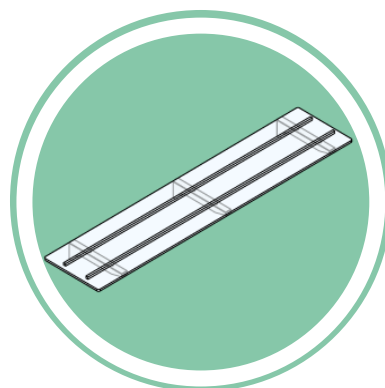

LOOSE UNITS ON OPEN CUPBOARD- WITH OPEN OR CLOSED STORAGE

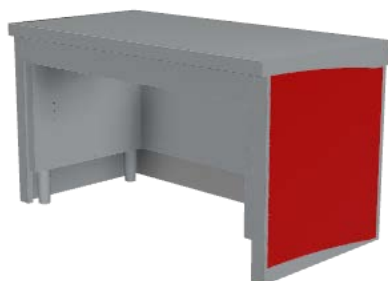

on open cupboard

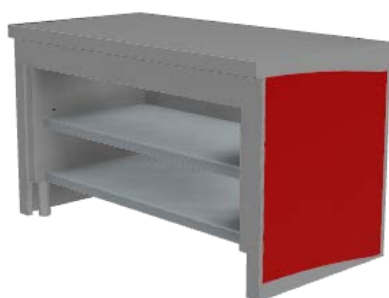

with open storage

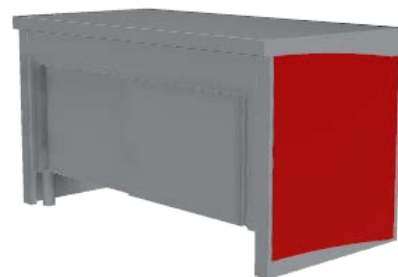

with closed storage

DESCRIPTION

AISI 304 stainless steel structure. AISI 304 stainless steel top thickness 2 mm. Rounded front edge. Laminate façade with 15 mm elevation. Includes 3-bar stainless steel handrail. Storage units with adjustable floor and shelf. Storage unit with sliding doors (note: 800 mm unit comes with swing door).

Loose units

Unit on open cupboard		
Length	Item no.	Price in € (plus VAT)
800	MNBL08PRI	3,139
1,200	MNBL12PRI	3,817
1,600	MNBL16PRI	3,998
2,000	MNBL20PRI	4,638
2,300	MNBL23PRI	5,624

Unit with open storage	
Item no.	Price in € (plus VAT)
MNO08PRI	3,531
MNO12PRI	3,981
MNO16PRI	5,104

Unit with closed storage	
Item no.	Price in € (plus VAT)
MNF08PRI	3,753
MNF16PRI	5,126



AUXILIARY UNITS

EXTERNAL CORNER UNITS WITH ANGLED CORNERS

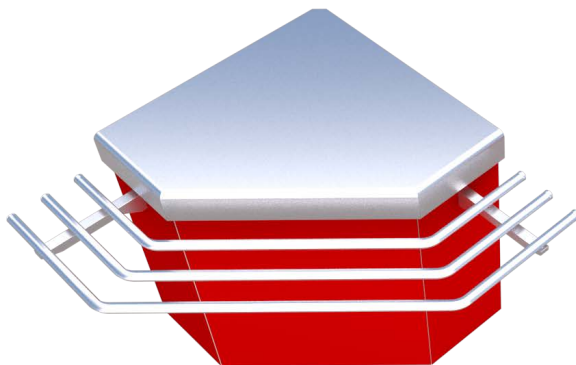

MAE90PRI
angled corners

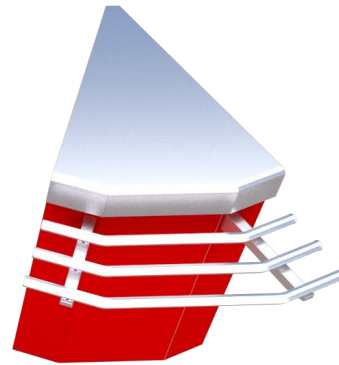

MAE45PRI
angled corners

DESCRIPTION

AISI 304 stainless steel structure. AISI 304 stainless steel top thickness 2 mm. Rounded front edge. Laminate façade with 15 mm elevation. Includes 3-bar stainless steel handrail.

External corner units with angled corners

Item no.	Description	Price in € (plus VAT)
MAE90PRI	90° corner (laminated façade on customer side). Unit (top + trim)	3,797
MAE45PRI	45° corner (laminated façade on customer side). Unit (top + trim)	2,072

INTERNAL CORNER UNITS WITH ANGLED OR ROUNDED CORNERS

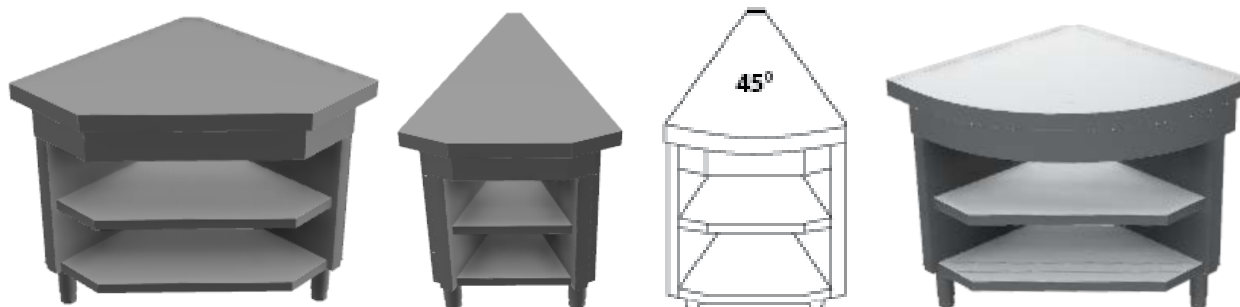

MAI90PRI

angled corners

MAI45PRI

MAIC45PRI

rounded edges

MAIC90PRI

DESCRIPTION

Unit top with 3 corners and intermediate floor and shelf.

Internal corner units with angled corners

Item no.	Description	Price in € (plus VAT) Stainless steel top
MAI90PRI	90° corner (open on service side). Unit (top + trim)	3,930
MAI45PRI	45° corner (open on service side). Unit (top + trim)	3,286
PS90PRI	90° corner panel (open on service side). Top only	1,149
PS45PRI	45° corner panel (open on service side). Top only	960

Ask us about our plan stone and granite tops.

DESCRIPTION

Unit top with rounded edges intermediate floor and shelf.

Rounded internal corner units

Item no.	Description	Price in € (plus VAT) Stainless steel top
MAIC90PRI	90° corner (open on service side). Unit (top + trim)	5,357
MAIC4PRI	45° corner panel (open on service side). Top only	3,807

Ask us about our plan stone and granite tops.

GLASS, PLATE AND TRAY DISPENSERS

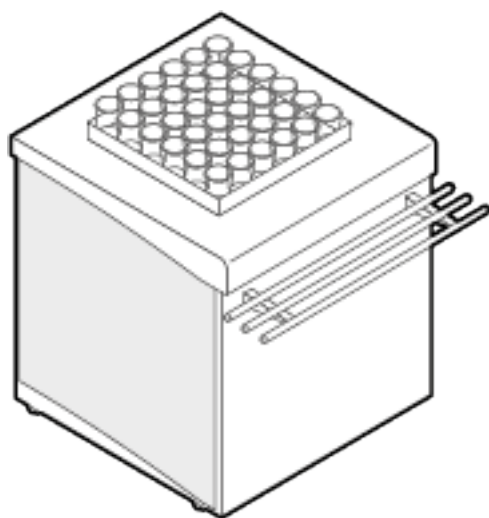

glass dispensers

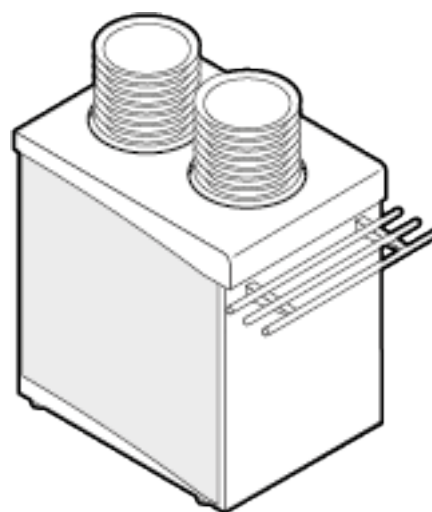

plate dispensers

DESCRIPTION

AISI 304 stainless steel structure. AISI 304 stainless steel top thickness 2 mm. Rounded front edge.

Laminate façade with 15 mm elevation. Includes 3-bar stainless steel handrail.

Constant output dispenser for storing and dispensing

- glasses. Capacity: 6 to 10 baskets (500 x 500)
- heated plates. Capacity: 110 plates. Power: 110 w
- trays. Capacity: 110 trays.

Utensil dispensers

Item no.	Length	Description	Price in € (plus VAT)
DVA80PRI	800	Glass dispensers	4,942
DAA45PRI	500	Plate dispenser	6,045
DPA80PRI	800	Tray dispenser	4,942



AUXILIARY UNITS

FRONT & RETURN ELEMENTS

Enodis
CHILD

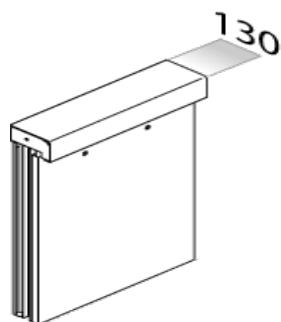

front element

DESCRIPTION

AISI 304 stainless steel structure. AISI 304 stainless steel top thickness 2 mm. Rounded front edge. Laminate façade with 15 mm elevation. Includes 3-bar stainless steel handrail. The front element can be used to connect two units to modify your configuration or it can be used as trolley storage.

Front elements

Item no.	Description	Length	Price in € (plus VAT) Stainless steel top
EF50PRI	Front element	500	1,282
EF60PRI	Front element	600	1,436
EF12PRI	Front element	1,200	2,021
EF16PRI	Front element	1,600	2,503
EF20PRI	Front element	2,000	2,933
EF23PRI	Front element	2,300	3,153

FRONT ELEMENT ADD-ON			
Item no.	Name	Length	Price in € (plus VAT) Stainless steel top
BDRPRI	Return element	830	1,164

STAINLESS STEEL TRAY SLIDES & QUEUE RAILINGS

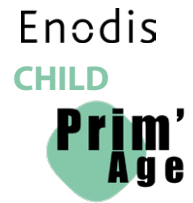

stainless steel rail slide included

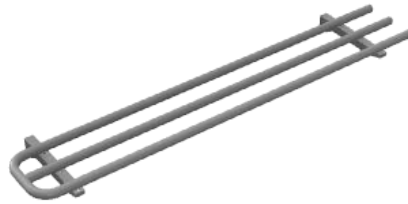

with end bracket

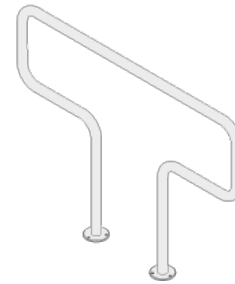

stainless steel queue railing

DESCRIPTION

Rail slides included
Standard: separate tray slide for each unit consisting of 3 brushed stainless steel bars diameter 32 mounted on stainless steel brackets.

3-bar stainless steel rails

Item no.	Name	Price in € (plus VAT)
RPI3	3-bar stainless steel rail goes with the self-service unit (per linear metre)	284
MVRPI305	Deduction when purchased without stainless steel rail for 500 mm unit	-130
MVRPI306	Deduction when purchased without stainless steel rail for 600 mm unit	-157
MVRPI308	Deduction when purchased without stainless steel rail for 800 mm unit	-209
MVRPI309	Deduction when purchased without stainless steel rail for 900 mm unit	-235
MVRPI312	Deduction when purchased without stainless steel rail for 1,200 mm unit	-326
MVRPI313	Deduction when purchased without stainless steel rail for 1,250 mm unit	-326
MVRPI314	Deduction when purchased without stainless steel rail for 1,400 mm unit	-351
MVRPI315	Deduction when purchased without stainless steel rail for 1,500 mm unit	-391
MVRPI316	Deduction when purchased without stainless steel rail for 1,600 mm unit	-429
MVRPI320	Deduction when purchased without stainless steel rail for 2,000 mm unit	-522
MVRPI323	Deduction when purchased without stainless steel rail for 2,300 mm unit	-600
MVRPI326	Deduction when purchased without stainless steel rail for 2,600 mm unit	-866

DESCRIPTION

Made from 40 mm brushed stainless bars with stainless steel fixing plate. Height 900 mm.

Stainless steel rails diameter 40

Item no.	Length	Price in € (plus VAT)
RCB12PRI	1,200	712

RAILS AND RAILINGS AVAILABLE IN: GRANITE, GLASS AND LAMINATE

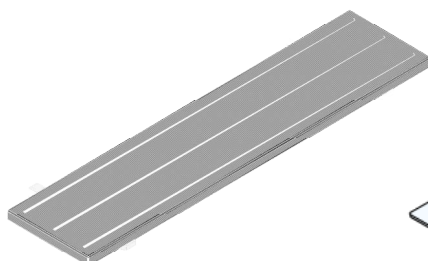
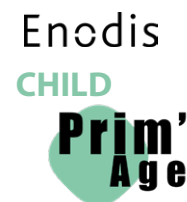

reconstituted stone and granite rail

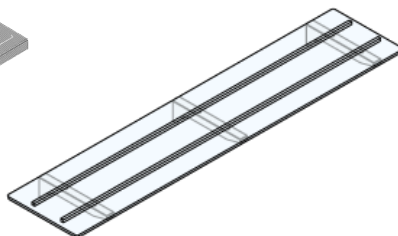

rails with LED lighting (available as add-on)

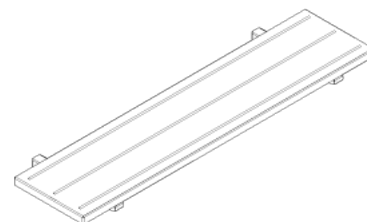

laminate rails

DESCRIPTION

Tray slides available in various materials (an additional charge will apply).

- Granite rail thickness 30 mm on stainless steel brackets. 3 stainless steel bars for sliding trays
- Tempered glass rail thickness 10 mm on stainless steel brackets includes 2 stainless steel slide bars.
- Laminate rail includes 3 stainless steel slide bars.

Tray slides

Description
Additional charge for 500 mm unit
Additional charge for 600 mm unit
Additional charge for 800 mm unit
Additional charge for 900 mm unit
Additional charge for 1,200 mm unit
Additional charge for 1,300 mm unit
Additional charge for 1,400 mm unit
Additional charge for 1,600 mm unit
Additional charge for 2,000 mm unit
Additional charge for 2,300 mm unit
Assembly for 45° corner
Assembly for 90° corner
Additional charge for 90° corner on curved unit
Additional charge for 45° corner on curved unit
For 1,600 mm rectangular salad'bar
For 2,000 mm rectangular salad'bar
For 2,300 mm rectangular salad'bar
For 1,400 mm rectangular salad'bar
For 1,800 mm rectangular salad'bar

Glass	
Item no.	Price in € (plus VAT)
RV08	632
RV12	934
RV13	960
RV16	1,227
RV20	1,851
RV23	1,923
AV45	2,055
AV90	2,837
RVMA90	2,909
RVMA45	2,225
RV16SB	2,449
RV20SB	3,701
RV23SB	3,843
RV14SBO	6,897
RV18SBO	8,269

Laminate	
Item no.	Price in € (plus VAT)
RS05	398
RS06	447
RS08	461
RS09	475
RS12	660
RS13	680
RS14	704
RS16	849
RS20	1,351
RS23	1,363
AS45	1,383
AS90	1,928
RSMA90	2,909
RSMA45	2,225
RS16SB	1,692
RS20SB	2,697
RS23SB	2,724
RS14SBO	5,340
RS18SBO	6,435

Please ask us about our reconstituted stone & granite rails.

ADD-ONS FOR AUXILIARY UNITS

Enodis
CHILD



COMPATIBLE ADD-ONS FOR AUXILIARY UNITS		
Item no.	Description	Price in € (plus VAT)
EMB09	Lower shelf for unit on open cupboard for unit length 900 mm	328
EMB10	Lower shelf for unit on open cupboard for unit length 1,000 mm	312
EMB12	Lower shelf for unit on open cupboard for unit length 1,200 mm	338
EMB14	Lower shelf for unit on open cupboard for unit length 1,400 mm	387
EMB15	Lower shelf for unit on open cupboard for unit length 1,500 mm	389
EMB16	Lower shelf for unit on open cupboard for unit length 1,600 mm	396
EMB17	Lower shelf for unit on open cupboard for unit length 1,700 mm	471
EMB20	Lower shelf for unit on open cupboard for unit length 2,000 mm	489
EMB23	Lower shelf for unit on open cupboard for unit length 2,300 mm	561
PVDV	Additional charge for vibrated top (per LM)	393
BPM	Mirror polished front edge (per LM)	162
CEPO	Laminate end panel (per unit)	490
CEPORPI	Laminate side with rounded lateral edge and rail (per unit)	1,110
PLE	Stainless steel plinths with 150 mm elevation (per LM)	222
DGN1	Cut-out for GN1/1 (tray not included)	154
DGN2	Cut-out for GN2/1 (tray not included)	209
AGC	Air vent on customer side via opening in the laminate (per unit)	870
RPP412I	Set of 4 stainless steel wheels diameter 125 mm (2 with brakes) for < 2,000 mm unit	316
PCN220	16A power socket not protected/connected (per unit)	167
PCA	Arnould socket (per unit)	338
PCTri	Tri-phase socket (per unit)	281
FCPC	Lock with key for loose unit with sliding door (one for each unit)	99
TBCAV	Front control panel	393
TBCD	Right-side customer-facing control panel	393
TBCG	Left-side customer-facing control panel	393
ALH	Power supply via the top from a cabinet (maximum bar height 3,000 mm with mobile stainless steel plate to be fixed to the ceiling)	469
BIPR	Protective stainless steel strip (between counter top and tray slide) (per LM)	170
HSPERPI	Special tray slide height (815 mm to 830 mm elevation) (per cabinet)	294
BSC	Ventilated tank separator bar (per unit)	62
TDSB	Smoked Plexiglas plate shelf for salad bar + fixings (per unit)	356
BGPR	Protective granite strip (between counter top and tray slide) (per LM)	401
LEDB	Additional charge for White LED lighting in glass rail or underneath rail, work counter or plinth	486
LEDRGB	Additional charge for Multicolour LED lighting in glass rail or underneath rail, work counter or plinth	603
REGETC	Additional charge for EasyTouch controls for heated unit with USB socket and dynamic lighting	669
REGETF	Additional charge for EasyTouch controls for heated unit with USB socket and dynamic lighting	784

RAIL ADD-ONS		
Item no.	Name	Price in € (plus VAT)
BGPR	Protective granite strip between counter top and tray slide (per LM)	401
LEDB	Additional charge for White LED lighting in glass rail or underneath rail, work counter or plinth	486
LEDRGB	Additional charge for Multicolour LED lighting in glass rail or underneath rail, work counter or plinth	603

05 ORGANISERS

Technical Information

- **All AISI 304 (18-10) stainless steel** construction .
- AISI 304 stainless steel **top thickness 2 mm** with 220 grain satin polish (**scotch-brite**).
Customer side counter surface profile 20 mm rounded edge with **110 mm drop**.
Service side counter surface straight edge with **60 mm drop**.
Available as add-on: granite or reconstituted stone top thickness 30 mm (one piece per unit).
Granite or reconstituted stone top finished with straight edge on service side and end and rounded edge on customer side.
- Depth 830 mm, height 750 mm on stainless steel base height 180 mm adjustable -25/+50 mm.
- Units must be bolted at front and rear with sealant between **clean edge** panelling.
- Tray slide brackets in AISI 304 stainless steel fitted to frame through laminated front to ensure tray slide is fully aligned.
- **Standard stainless steel tray rail 3 profiled bars diameter 32 mm (included in unit price)**.
Available as add-on: granite rail, reconstituted stone rail, glass rail or laminate rail.
- Customer side **façade** as standard in **water-repellent melamine** coated in double-sided laminate **thickness 20 mm. 15 mm elevation** with lower stainless steel corner guard.
Available on request: 180 mm to 15 mm façade elevation with lower stainless steel corner guard.
Panels are fitted with an interlocking clip system and held in place by brackets.
Service side fascia panel attached with easily removable screws for access.
- **250 colours** to choose from our colour chart.

CLEARING UNITS

Enodis
CHILD

Prim'
Age



DESCRIPTION

AISI 304 stainless steel structure. AISI 304 stainless steel top thickness 2 mm. Rounded front edge. Laminate façade with 15 mm elevation. Includes 3-bar stainless steel handrail. Unit with or without return arm. Foot rest. Lockable stainless steel drawer with key. Cable entry aperture on top surface top. Width: 830 mm, height: 750 mm. Socket not connected.

Loose units on open cupboard

Item no.	Dimensions W x D x H	Price in € (plus VAT)
MNBL08PRI	800 x 830 x 750	3,139
MNBL12PRI	1,200 x 830 x 750	3,817
MNBL16PRI	1,600 x 830 x 750	3,998
MNBL17PRI	1,700 x 830 x 750	3,113
MNBL20PRI	2,000 x 830 x 750	4,638
MNBL23PRI	2,300 x 830 x 750	5,624

Laminate-coated customer side doors - swing or sliding

Swing doors item no.	Price in € (plus VAT)	Description	Swing doors item no.	Price in € (plus VAT)
PBATT08	903	Additional charge for 800 mm unit door	PCOULC08	1,806
PBATT12	1,806	Additional charge for 1,200 mm unit door	PCOULC12	1,806
PBATT16	1,806	Additional charge for 1,600 mm unit door	PCOULC16	1,806
PBATT17	1,806	Additional charge for 1,700 mm unit door	PCOULC17	1,806
PBATT20	2,287	Additional charge for 2,000 mm unit door	PCOULC20	2,287
PBATT23	2,740	Additional charge for 2,300 mm unit door	PCOULC23	2,740

Top with 30 mm recess with diamond pattern

Item no.	Length (mm)	Price in € (plus VAT)
DEC510	510 x 510 for 1 bin	695
DEC1020	1,020 x 510 for 2 bins	832
DEC1530	1,530 x 510 for 3 bins	924
DEC2020	2,020 x 510 for 4 bins	1,231

WASTE-SORTING UNIT

Enodis
CHILD

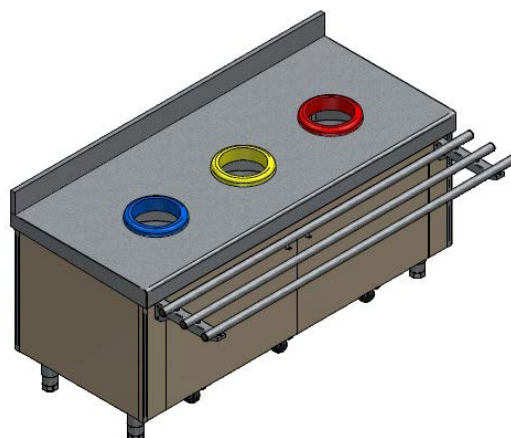

DESCRIPTION

AISI 304 stainless steel structure. AISI 304 stainless steel top thickness 2 mm. Rounded front edge.
Laminate façade with 15 mm elevation.
Includes 3-bar stainless steel handrail that folds upward.
Rear backsplash 100 mm.
Comes with mobile bins + coloured collar (please specify).

ORGANISERS

Loose units on open cupboard - stainless steel top

Item no.	Dimensions W x D x H	Price in € (plus VAT)
MNTA2CPRI	1,200 x 700 x 750	11,298
MNTA3CPRI	160 x 700 x 750	13,222

WASTE-SORTING UNIT ADD-ONS		
Item no.	Description	Price in € (plus VAT)
COLLERETTE-C-BLEU	Blue rubber collar for waste sorting chute	185
COLLERETTE-C-JAUNE	Yellow rubber collar for waste sorting chute	185
COLLERETTE-C-ROUGE	Red rubber collar for waste sorting chute	185
COLLERETTE-C-VERTE	Green rubber collar for waste sorting chute	185
PLAQUETRI SELECTIF	A4 stainless steel sign hooks to front (per unit)	120



WASTE-SORTING UNIT ADD-ONS

Enodis
CHILD



QUEUE BARRIER ADD-ONS		
Item no.	Name	Price in € (plus VAT)
EMB08	Lower shelf for unit on open cupboard 800 mm	292
EMB12	Lower shelf for unit on open cupboard 1,200 mm	338
EMB16	Lower shelf for unit on open cupboard 1,600 mm	396
EMB17	Lower shelf for unit on open cupboard 1,700 mm	471
EMB20	Lower shelf for unit on open cupboard 2,000 mm	489
EMB23	Lower shelf for unit on open cupboard 2,300 mm	561
CEPO	Laminate end panel (per unit)	490
VDC	Waste chute with anti-shock collar	381
RPP412I	Set of 4 stainless steel wheels diameter 125 mm (2 with brakes) for < 2,000 mm unit	316
DGN1	Cut-out for GN1/1 (tray not included)	154
DGN2	Cut-out for GN2/1 (tray not included)	209
BAR	Anti-runoff edge.	484
DO	Rear backsplash (per linear metre)	614
ARPI3	Stainless steel rails flap	1,025
CE3ES	End bracket	190
AAI3	Corner joint for 2 straight sections	625



BESPOKE SELF-SERVICE UNITS





BESPOKE
SELF-SERVICE
UNITS



All our self-service units are made to measure.

01

FROM CONCEPTION TO COMPLETION

A line of products designed for you, to make your restaurant attractive, colourful, dynamic and shimmering with LED lighting in an environmentally friendly way.

The self-service unit is designed with select materials and transparent display glass - all working to highlight your food displays and present appetising choices.

Modern, innovative, designer lines with stainless steel or wood plinths.

Custom-built display units made from the finest materials: reconstituted stone, Corian, granite, stainless steel and laminate, to name a few.

Enodis manufactures self-service units that showcase chef's hard work.

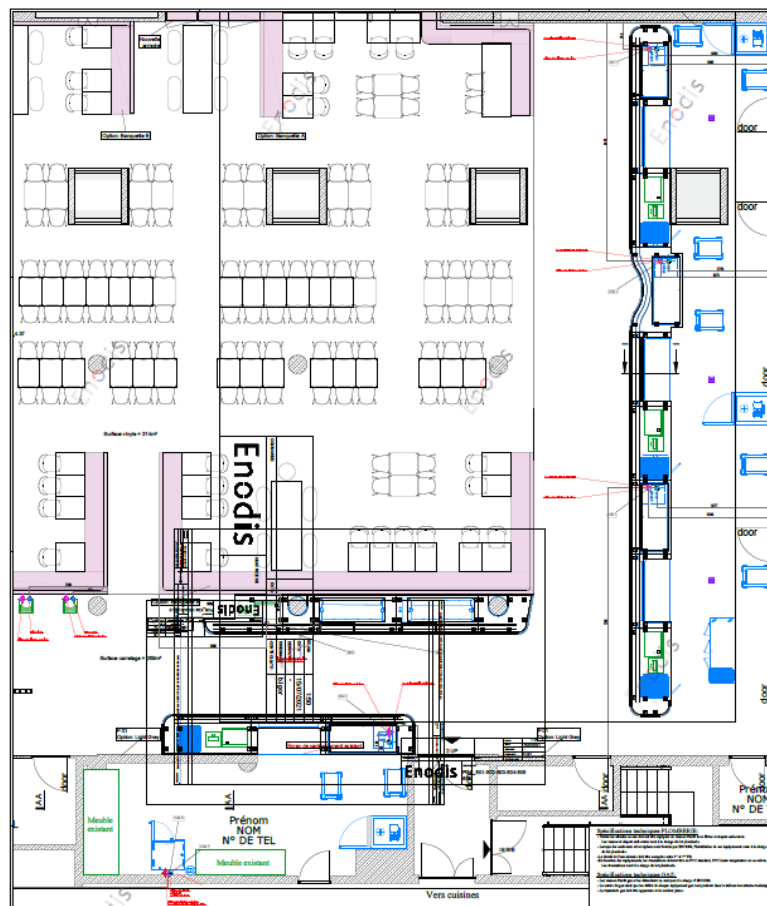

BESPOKE SELF-SERVICE UNITS

Enodis
BESPOKE SELF-SERVICE UNITS

Prestige

02

BESPOKE SELF-SERVICE UNITS

MADE TO YOUR MEASURE

Hygienic:

- Radiant tank
- Radiant heat chamber
- Refrigerated storage with shelving
- Tops assembled with clean edges
- Lip seals on refrigerated doors with easy tool-free removal.

High performance:

- Electric elements located underneath tank
- Refrigeration system noise level 56 dB(A).
- Comes with removable bottom.

Design:

- Stainless steel rail with connecting sleeve
- Curved glass display counter on stainless steel columns
- Stainless steel corner guard
- Laminate façade with 15 mm elevation standard finish (stainless steel plinth available on request)

Energy saving:

- Energy-saving, high-efficiency display cabinets
- Touch controls
- Clock with start-up and shut-down times
- 100% LED lighting

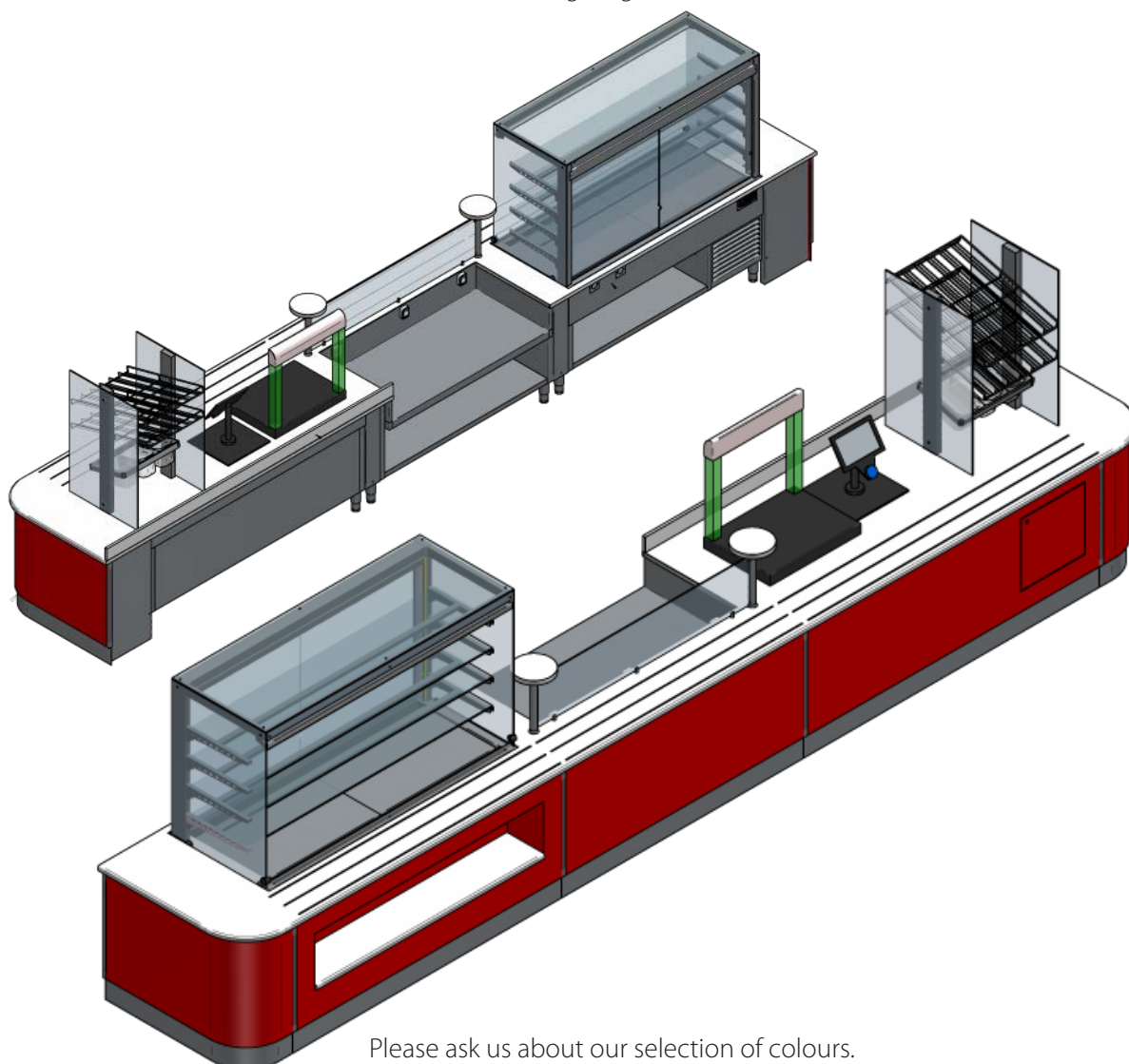

Please ask us about our selection of colours.

Le Veggies Vegan

A multi-tiered glass display case filled with various vegan food items. The top shelves feature fresh green salads and sandwiches. The middle shelves are stocked with a variety of fruits, including strawberries, oranges, and lemons, along with small containers of dips and spreads. The bottom shelves are filled with an assortment of bottled and canned beverages, including juices and soft drinks. The display case is illuminated from within, highlighting the freshness of the ingredients.

Le Veggie
Vegan
Menu items and prices listed on a small blackboard sign.

A stainless steel kitchen counter with a stovetop. On the counter, there are stacks of white plates and a bowl of prepared food, possibly a salad or a cooked vegetable dish. The counter is clean and organized, with various kitchen tools and ingredients visible in the background.

A wooden counter with two stacks of white plates tucked into a recessed area. The counter is made of light-colored wood and has a clean, modern look. The plates are neatly stacked and ready for use.





PLEASE READ:
RECEPTIONIST'S GUIDE TO RECEIVING

- 1. Greet the customer with a smile and a friendly "Good morning/afternoon/evening".
- 2. Listen carefully to the customer's request and repeat it back to ensure you have understood correctly.
- 3. If you are unsure of the answer, do not guess. Ask a colleague or supervisor for assistance.
- 4. If the customer is waiting, apologize and offer them a drink of water or a small gift.
- 5. Thank the customer for their patience and assistance.



BUILT-IN



Technical Information

- **All AISI 304 (18-10) stainless steel** construction .
- AISI 304 stainless steel **top thickness 2 mm vibrated and polished.**

Built-in modules

- These built-in designs will fit flawlessly into your restaurant. Our display cabinets and refrigerated units always maintain an optimal temperature. All modules are installed quickly and efficiently.
- Optimise the space in your restaurant and relax your surroundings with the wonderful colours and materials we have to offer.
- Performance, design, versatility and energy-efficiency are the 4 major selling points of our built-in ranges.
- Our refrigeration units are very quiet at just 56dB (A) with environmentally-friendly LED lighting throughout the range.
- A complete range that's easy to use, ergonomic and stylish - and blends with any décor.

01

UTENSIL
DISPENSERS..... 198

02

202..... COLD

03

HOT..... 216



BUILT-IN

01

UTENSIL DISPENSERS



LA CLEMENTINE DE CORSE
Les Clementines de Corse sont les plus belles et les plus suaves.
Elles sont produites dans le département de la Corse.
On peut les acheter partout en France.

CONSTANT OUTPUT DISPENSERS FOR TRAYS, RACKS & PLATES

Enodis
BUILT-IN

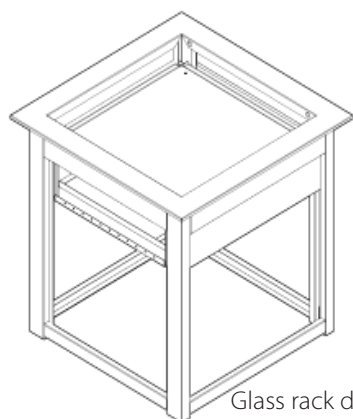

Glass rack dispenser

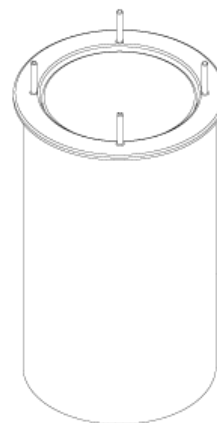

Plate dispenser

DESCRIPTION

AISI 304 stainless steel structure. Vibrated and polished. Built-in constant output dispenser for storing:

- glasses. Capacity: 5 baskets (500 x 500)
- heated plates. Capacity: 55 plates. Power: 110w. 240 v single-phase power supply.
- trays. Capacity: 120 trays.

Plate, rack and tray dispensers

Item no.	Description	Capacity	Price in € (plus VAT)
DIPLAT	Constant output tray dispensers	120	3,109
DICAS	Constant output rack dispenser	5	2,845
DISASN1	Constant output plate dispenser loose 240-260	55	1,052
DISASC1	Constant output plate dispenser heated 240-260	55	1,646
DISASN2	Constant output plate dispenser loose 260-310	55	1,141
DISASC2	Constant output plate dispenser heated 260-310	55	1,889



02

COLD UNITS

Technical Information

- **All AISI 304 (18-10) stainless steel** construction .
- AISI 304 stainless steel **top thickness 2 mm vibrated and polished.**

Specifications

- **Refrigerated tank with static cooling** with welded rounded corners and diamond pattern toward drain plug. Injected with polyurethane foam insulation. Available with **30 mm or 110 mm recess**. Temperature range -10°C to +5°C
- **Refrigerated tank with ventilated cooling** with welded rounded corners and diamond pattern toward drain plug. Injected with polyurethane foam insulation. Available with **30 mm or 110 mm recess**. Temperature range -10°C to 5°C.
- **Refrigeration system noise level 56dB(A)**. Uses refrigerant **R455A** (GWP of 146), power supply single-phase 230 volts. **Comes with removable frame.**
- Touch-key controls.
-
- **Available as add-on:** Drip tray
EasyTouch control panel
The positioning of the refrigeration unit can be changed on request
- Other refrigerants available on request: R290.
- Compatible remote refrigeration units available: CO2, R134A, R404A, R407F, R448A, R449A, R452A, R513A, glycolated water (please confirm fluid when placing your order).

Complies with AFNOR standard AC D 40-004 (the French industrial standards authority).

REFRIGERATED WELL - FOR STARTERS Enodis BUILT-IN

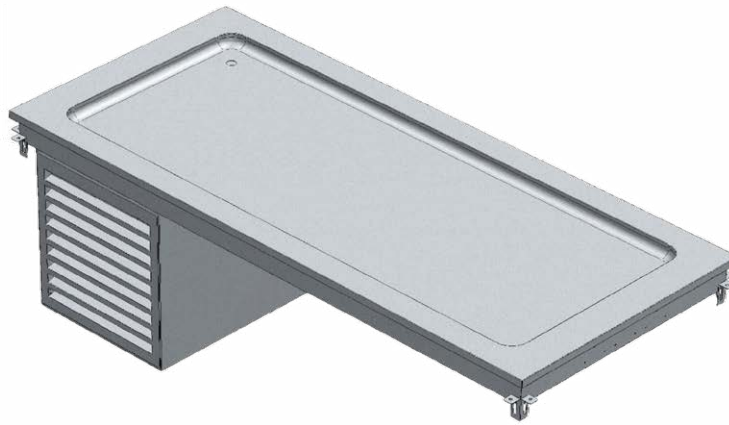

DESCRIPTION

Built-in refrigerated well with static cooling and 30 mm recess - ideal for displaying starters. HCFO foam insulation.
 AISI 304 stainless steel structure. Operating temperature: 2°C/10°C.
 Refrigeration system noise level 56 dB(A). Comes with removable bottom. Uses refrigerant R455A.
 240 v single-phase power supply. Vibrated and polished.

Refrigerated well - for displaying starters - with or without refrigeration unit

Item no.	Tank	Dimensions	With refrigeration unit	
			Power w	Price in € (plus VAT)
DICRH2	2 GN1/1	810 x 640 x 510	350	3,946
DICRH3	3 GN1/1	1,135 x 640 x 510	350	3,978
DICRH4	4 GN1/1	1,460 x 640 x 510	450	4,439
DICRH5	5 GN1/1	1,785 x 640 x 510	700	4,892
DICRH6	6 GN1/1	2,110 x 640 x 510	700	5,335

Item no.	Without refrigeration unit	
	Power w	Price in € (plus VAT)
DICRSGH2	-	2,757
DICRSGH3	-	2,789
DICRSGH4	-	3,061
DICRSGH5	-	3,398
DICRSGH6	-	3,844

Please ask us about changing the positioning of your refrigeration unit.
BE14L - add-on drip tray: €544

REFRIGERATED DRINKS WELL

Enodis
BUILT-IN

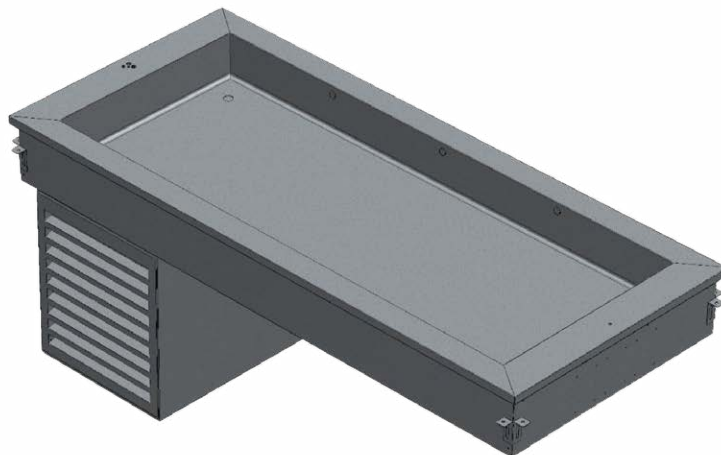

DESCRIPTION

Built-in refrigerated well with static cooling and 110 mm recess - ideal for displaying drinks.
 HCFO foam insulation.
 AISI 304 stainless steel structure. Operating temperature: 2°C/10°C.
 Refrigeration system noise level 56 dB(A). Comes with removable bottom. Uses refrigerant R455A.
 240 v single-phase power supply. Vibrated and polished.

COLD UNITS

Refrigerated drinks well - with or without refrigeration unit

Item no.	Tank	Dimensions	With refrigeration unit	
			Power w	Price in € (plus VAT)
DICRB2	2 GN1/1	810 x 640 x 510	350	4,433
DICRB3	3 GN1/1	1135 x 640 x 510	350	4,496
DICRB4	4 GN1/1	1,460 x 640 x 510	450	5,340
DICRB5	5 GN1/1	1,785 x 640 x 510	700	5,596
DICRB6	6 GN1/1	2,110 x 640 x 510	700	5,962

Item no.	Without refrigeration unit	
	Power w	Price in € (plus VAT)
DICRSGB2	-	3,244
DICRSGB3	-	3,310
DICRSGB4	-	4,092
DICRSGB5	-	4,102
DICRSGB6	-	4,468

Please ask us about changing the positioning of your refrigeration unit.

BE14L - add-on drip tray: €544

VENTILATED REFRIGERATED DROP-IN WELLS

Enodis
BUILT-IN

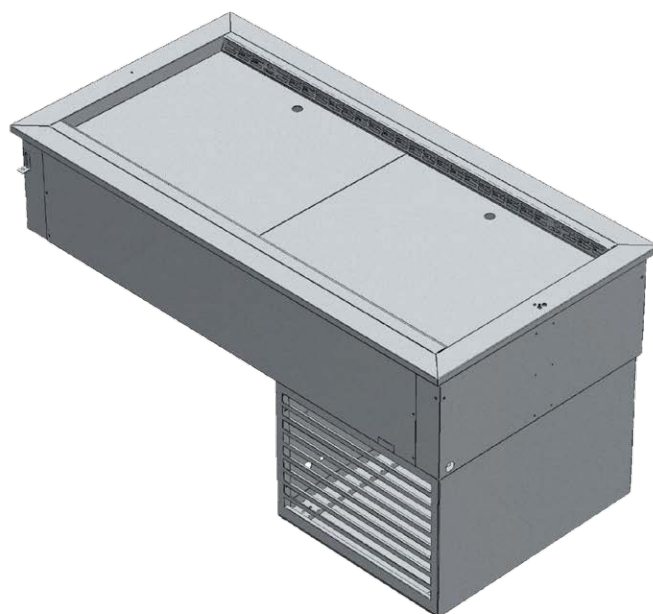

DESCRIPTION

Ventilated tank, base in 2 depth-adjustable parts (30 to 110 mm). Front suction to form the air curtain. AISI 304 stainless steel structure. HCFO foam insulation. Ventilated evaporator with tilting actuators for full access and cleaning (with UVC lamp). Operating temperature: 2°C/10°C. Refrigeration system noise level 56 dB(A). Comes with removable bottom. Uses refrigerant R455A. 240 v single-phase power supply. Vibrated and polished.

Ventilated refrigerated drop-in wells

Item no.	Tank	Dimensions	With refrigeration unit	
			Power w	Price in € (plus VAT)
DICFV02	2 GN1/1	810 x 640 x 510	350	8,115
DICFV03	3 GN1/1	1,135 x 640 x 510	350	9,212
DICFV04	4 GN1/1	1,460 x 640 x 510	450	10,317
DICFV05	5 GN1/1	1,785 x 640 x 510	700	11,238
DICFV06	6 GN1/1	2,110 x 640 x 510	700	13,937

Without refrigeration unit		
Item no.	Power w	Price in € (plus VAT)
DICSGFV02	-	5,989
DICSGFV03	-	6,754
DICSGFV04	-	7,434
DICSGFV05	-	8,048

Please ask us about changing the positioning of your refrigeration unit.
BE14L - add-on drip tray: €544

LOOSE INSULATED DROP-IN WELLS CONDENSATE DRIP TRAY

Enodis
BUILT-IN

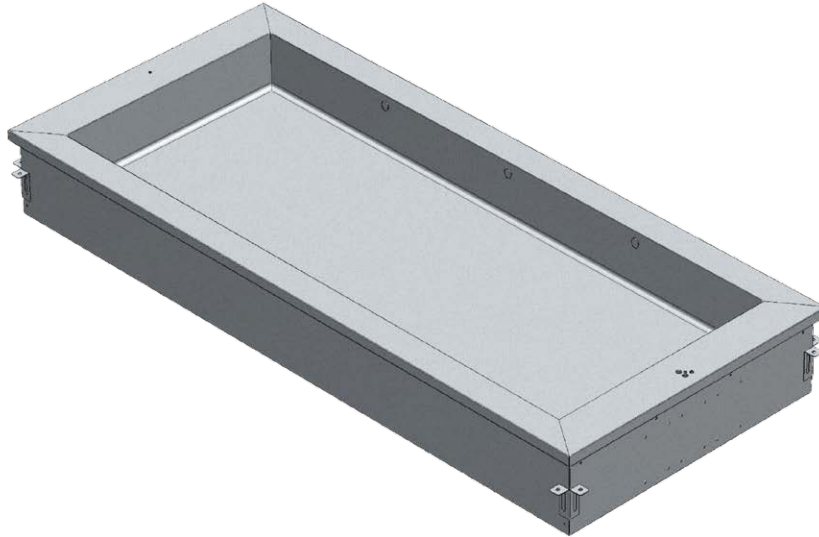

DESCRIPTION

Built-in drop-in well AISI 304 stainless steel (fully welded). Rounded corners with depth of 215 mm for 2, 3, 4, 5 and 6 GN1/1 trays and/or bed of ice. HCFO foam insulation. 1/2 drainage. Can be accessorised with superstructure, lighting and drip tray. Vibrated and polished.

Loose insulated drop-in well

Item no.	Tank	Dimensions	Price in € (plus VAT)
DIC2	2 GN1/1	810 x 640 x 510	1,774
DIC3	3 GN1/1	1,135 x 640 x 510	1,991
DIC4	4 GN1/1	1,460 x 640 x 510	2,391
DIC5	5 GN1/1	1,785 x 640 x 510	2,581
DIC6	6 GN1/1	2,110 x 640 x 510	2,822

REFRIGERATED DROP-IN TOP UNITS ON 2 TIERS

Enodis
BUILT-IN

Please ask us about changing the positioning of your refrigeration unit.

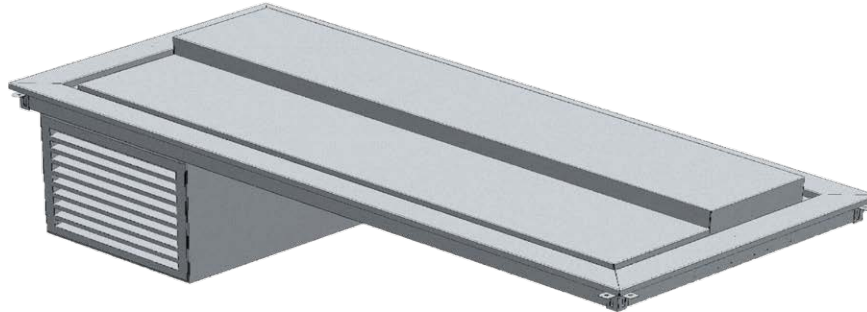

DESCRIPTION

Built-in cold food display unit - can be displayed in containers or on plates. AISI 304 stainless steel with peripheral drainage channel. Static refrigeration with HCFO foam insulation. Refrigeration system noise level 56 dB(A). Comes with removable bottom. Uses refrigerant R455A. Control panel with on/off switch, thermostat and thermometer. Drainage 2 x 10 mm. Can be accessorised with superstructure and lighting. single-phase 240 v - 50 Hz. Vibrated and polished.

Refrigerated drop-in top units (with refrigeration unit)

Item no.	Tank Tray capacity	Power (w) Electric	Dimensions W x D x H mm	Price in € (plus VAT) Stainless steel top
DIGRI2	2 GN1/1	350	810 x 640 x 490/570*	7,699
DIGRI3	3 GN1/1	350	1,135 x 640 x 490/570*	8,071
DIGRI4	4 GN1/1	450	1,460 x 640 x 490/570*	8,598
DIGRI5	5 GN1/1	700	1,785 x 640 x 490/570*	8,829
DIGRI6	6 GN1/1	700	2,110 x 640 x 490/570*	9,066

*490 mm = built-in height - 570 mm = total height
Ask us about our plan stone and granite tops.

BE14L - add-on drip tray: €544

BUILT-IN “CRISTALINE” REFRIGERATED DISPLAY CABINETS WITH REAR AIRFLOW SYSTEM - 2 LEVELS

Enodis
BUILT-IN

Please ask us about changing the positioning of your refrigeration unit.



DESCRIPTION

Built-in rectangular display cabinet. Refrigerated display cabinet with rear ventilation. Customer side open with thermal curtain or with closable glass cover on hydraulic cylinders for easy lifting and cleaning. 2 sliding doors in double-walled Plexiglas with micro-perforations to allow laminar airflow. HCFO foam insulation.

Ventilated tank, base in 2 depth-adjustable parts (30 to 110 mm), GN1/1 compatible with front suction to form the air curtain. Potentiometer for fan control to optimise operation and energy consumption.

2 height-adjustable intermediate shelves. LED lighting. Operating temperature: 2°C/10°C. Refrigeration system with removable bottom. Uses refrigerant R455A. 240 v single-phase power supply. Temperature display. Protection rating IP22. Refrigeration unit maximum noise level 56dB(A). Guaranteed performance at a maximum temperature of 25°C. Vibrated and polished.

BE14L - add-on drip tray: €544

“Cristaline” refrigerated display cabinets with rear airflow system - Open display cabinets with thermal curtain - 2 levels

Tank	Power Elec. / Refrig.	Dimensions W x D x H mm	Display cabinet with refrigeration unit	
			Item no.	Price in € (plus VAT)
2 GN1/1	800 / 972	810 x 740 x 725/1,350*	DIVO2C2	12,622
3 GN1/1	900 / 1,166	1,135 x 725/1,350*	DIVO2C3	13,896
4 GN1/1	1,200 / 1,573	1,460 x 725/1,350*	DIVO2C4	14,644
5 GN1/1	1,400 / 1,717	1,785 x 725/1,350*	DIVO2C5	15,595

Display cabinet without refrigeration unit	
Item no.	Price in € (plus VAT)
DIVSGO2C2	11,118
DIVSGO2C3	11,288
DIVSGO2C4	11,718
DIVSGO2C5	12,231

*725 mm = built-in height - 1,350 mm = total height

“Cristaline” refrigerated display cabinets with rear airflow system - Closed display cabinets with glass cover - 2 levels

Tank	Power Elec. / Refrig.	Dimensions W x D x H mm	Display cabinet with refrigeration unit	
			Item no.	Price in € (plus VAT)
2 GN1/1	800 / 972	810 x 740 x 725/1,350*	DIVF2C2	16,755
3 GN1/1	900 / 1,166	1,135 x 725/1,350*	DIVF2C3	16,891
4 GN1/1	1,200 / 1,573	1,460 x 725/1,350*	DIVF2C4	16,926
5 GN1/1	1,400 / 1,717	1,785 x 725/1,350*	DIVF2C5	17,791

Display cabinet without refrigeration unit	
Item no.	Price in € (plus VAT)
DIVSGF2C2	14,595
DIVSGF2C3	14,394
DIVSGF2C4	14,001
DIVSGF2C5	14,391

*725 mm = built-in height - 1,350 mm = total height

BUILT-IN “CRISTALINE” REFRIGERATED DISPLAY CABINETS WITH REAR AIRFLOW SYSTEM - 3 LEVELS

Enodis
BUILT-IN

Please ask us about changing the positioning of your refrigeration unit.



DESCRIPTION

Built-in rectangular display cabinet. Refrigerated display cabinet with rear ventilation. Customer side open with thermal curtain or with closable glass cover on hydraulic cylinders for easy lifting and cleaning. 2 sliding doors in double-walled Plexiglas with micro-perforations to allow laminar airflow. HCFO foam insulation. Ventilated tank, base in 2 depth-adjustable parts (30 to 110 mm), GN1/1 compatible with front suction to form the air curtain. Potentiometer for fan control to optimise operation and energy consumption.

3 height-adjustable intermediate shelves. LED lighting. Operating temperature: 2°C/10°C. Refrigeration system with removable bottom. Uses refrigerant R455A. 240 v single-phase power supply. Temperature display. Protection rating IP22. Refrigeration unit maximum noise level 56dB(A). Guaranteed performance at a maximum temperature of 25 °C. Vibrated and polished.

BE14L - add-on drip tray: €544

“Cristaline” refrigerated display cabinets with rear airflow system - Open display cabinets with thermal curtain - 3 levels

Tank	Power Elec. / Refrig.	Dimensions W x D x H mm	Display cabinet with refrigeration unit	
			Item no.	Price in € (plus VAT)
2 GN1/1	800 / 972	810 x 740 x 725/1,550*	DIVO3C2	14,373
3 GN1/1	900 / 1,166	1,135 x 740 x 725/1,550*	DIVO3C3	14,805
4 GN1/1	1,200 / 1,573	1,460 x 740 x 725/1,550*	DIVO3C4	15,688
5 GN1/1	1,400 / 1,717	1,785 x 740 x 725/1,550*	DIVO6C5	16,741

*725 mm = built-in height - 1,550 mm = total height

“Cristaline” refrigerated display cabinets with rear airflow system - Closed display cabinets with glass cover - 3 levels

Tank	Power Elec. / Refrig.	Dimensions W x D x H mm	Display cabinet with refrigeration unit	
			Item no.	Price in € (plus VAT)
2 GN1/1	800 / 972	810 x 740 x 725/1,550*	DIVF3C2	17,739
3 GN1/1	900 / 1,166	1,135 x 740 x 725/1,550*	DIVF3C3	17,800
4 GN1/1	1,200 / 1,573	1,460 x 740 x 725/1,550*	DIVF3C4	17,968
5 GN1/1	1,400 / 1,717	1,785 x 740 x 725/1,550*	DIVF3C5	18,781

*725 mm = built-in height - 1,550 mm = total height

BUILT-IN “CRISTALINE” REFRIGERATED DISPLAY CABINETS WITH REAR AIRFLOW SYSTEM - 4 LEVELS

Enodis
BUILT-IN

Please ask us about changing the positioning of your refrigeration unit.



DESCRIPTION

Built-in rectangular display cabinet. Refrigerated display cabinet with rear ventilation. Customer side open with thermal curtain or with closable glass cover on hydraulic cylinders for easy lifting and cleaning. 2 sliding doors in double-walled Plexiglas with micro-perforations to allow laminar airflow. HCFO foam insulation. Ventilated tank, base in 2 depth-adjustable parts (30 to 110 mm), GN1/1 compatible with front suction to form the air curtain. Potentiometer for fan control to optimise operation and energy consumption.

4 height-adjustable intermediate shelves. LED lighting. Operating temperature: 2°C/10°C. Refrigeration system with removable bottom. Uses refrigerant R455A. 240 v single-phase power supply. Temperature display. Protection rating IP22. Refrigeration unit maximum noise level 56dB(A). Guaranteed performance at a maximum temperature of 25°C. Vibrated and polished.

BE14L - add-on drip tray: €544

COLD UNITS

“Cristaline” refrigerated display cabinets with rear airflow system - Open display cabinets with thermal curtain - 4 levels

Tank	Power Elec. / Refrig.	Dimensions W x D x H mm	Display cabinet with refrigeration unit	
			Item no.	Price in € (plus VAT)
2 GN1/1	800 / 972	810 x 740 x 725/1,750*	DIVO4C2	14,373
3 GN1/1	900 / 1,166	1,135 x 740 x 725/1,750*	DIVO4C3	14,659
4 GN1/1	1,200 / 1,573	1,460 x 740 x 725/1,750*	DIVO4C4	15,688
5 GN1/1	1,400 / 1,717	1,785 x 740 x 725/1,750*	DIVO4C5	16,741

*725 mm = built-in height - 1,750 mm = total height

“Cristaline” refrigerated display cabinets with rear airflow system - Closed display cabinets with glass cover - 4 levels

Tank	Power Elec. / Refrig.	Dimensions W x D x H mm	Display cabinet with refrigeration unit	
			Item no.	Price in € (plus VAT)
2 GN1/1	800 / 972	810 x 740 x 725/1,750*	DIVF4C2	17,739
3 GN1/1	900 / 1,166	1,135 x 740 x 725/1,750*	DIVF4C3	17,800
4 GN1/1	1,200 / 1,573	1,460 x 740 x 725/1,750*	DIVF4C4	17,968
5 GN1/1	1,400 / 1,717	1,785 x 740 x 725/1,750*	DIVF4C5	18,781

*725 mm = built-in height - 1,750 mm = total height

BUILT-IN “ÉLÉGANCE” REFRIGERATED DISPLAY CABINETS WITH REAR AIRFLOW SYSTEM - 2 LEVELS

Enodis
BUILT-IN

Please ask us about changing the positioning of your refrigeration unit.



DESCRIPTION

Built-in rounded display cabinet. Refrigerated display cabinet with rear ventilation. Customer side open with thermal curtain or with closable glass cover on hydraulic cylinders for easy lifting and cleaning. 2 sliding doors in double-walled Plexiglas with micro-perforations to allow laminar airflow. HCFO foam insulation. Ventilated tank, base in 2 depth-adjustable parts (30 to 110 mm), GN1/1 compatible with front suction to form the air curtain. Potentiometer for fan control to optimise operation and energy consumption.

2 height-adjustable intermediate shelves. LED lighting. Operating temperature: 2°C/10°C. Refrigeration system with removable bottom. Uses refrigerant R455A. 240 v single-phase power supply. Temperature display. Protection rating IP22. Refrigeration unit maximum noise level 56dB(A). Guaranteed performance at a maximum temperature of 25 °C. Vibrated and polished.

BE14L - add-on drip tray: €544

“Élégance” refrigerated display cabinets with rear airflow system - Open display cabinets with thermal curtain - 2 levels

Tank	Power Elec. / Refrig.	Dimensions W x D x H mm	Display cabinet with refrigeration unit	
			Item no.	Price in € (plus VAT)
2 GN1/1	800 / 972	810 x 740 x 725/1,350*	DIVO2A2	13,385
3 GN1/1	900 / 1,166	1,135 x 725/1,350*	DIVO2A3	13,896
4 GN1/1	1,200 / 1,573	1,460 x 725/1,350*	DIVO2A4	14,644
5 GN1/1	1,400 / 1,717	1,785 x 725/1,350*	DIVO2A5	15,750

Display cabinet without refrigeration unit	
Item no.	Price in € (plus VAT)
DIVSGO2A2	11,229
DIVSGO2A3	11,401
DIVSGO2A4	11,718
DIVSGO2A5	12,353

*725 mm = built-in height - 1,350 mm = total height

BUILT-IN “ÉLÉGANCE” REFRIGERATED DISPLAY CABINETS WITH REAR AIRFLOW SYSTEM - 3 LEVELS

Enodis
BUILT-IN

Please ask us about changing the positioning of your refrigeration unit.



DESCRIPTION

Built-in rounded display cabinet. Refrigerated display cabinet with rear ventilation. Customer side open with thermal curtain or with closable glass cover on hydraulic cylinders for easy lifting and cleaning. 2 sliding doors in double-walled Plexiglas with micro-perforations to allow laminar airflow. HCFO foam insulation. Ventilated tank, base in 2 depth-adjustable parts (30 to 110 mm), GN1/1 compatible with front suction to form the air curtain. Potentiometer for fan control to optimise operation and energy consumption.

3 height-adjustable intermediate shelves. LED lighting. Operating temperature: 2°C/10°C. Refrigeration system with removable bottom. Uses refrigerant R455A. 240 v single-phase power supply. Temperature display. Protection rating IP22. Refrigeration unit maximum noise level 56dB(A). Guaranteed performance at a maximum temperature of 25°C. Vibrated and polished.

BE14L - add-on drip tray: €544

“Élégance” refrigerated display cabinets with rear airflow system - Open display cabinets with thermal curtain - 3 levels

Tank	Power Elec. / Refrig.	Dimensions W x D x H mm	Display cabinet with refrigeration unit	
			Item no.	Price in € (plus VAT)
2 GN1/1	800 / 972	810 x 740 x 725/1,550*	DIVO3A2	14,373
3 GN1/1	900 / 1,166	1,135 x 725/1,550*	DIVO3A3	14,805
4 GN1/1	1,200 / 1,573	1,460 x 725/1,550*	DIVO3A4	15,688
5 GN1/1	1,400 / 1,717	1,785 x 725/1,550*	DIVO3A5	16,741

*725 mm = built-in height - 1,550 mm = total height

DISPLAY COUNTERS FOR BUILT-IN REFRIGERATED ELEMENTS

Enodis
BUILT-IN

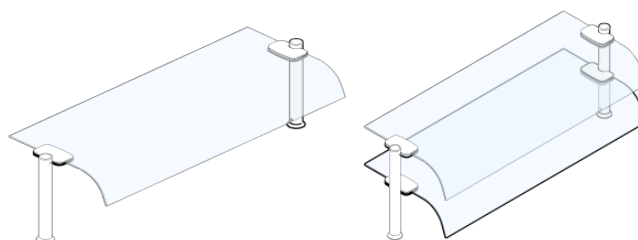

DESCRIPTION

single shelf

double shelf

Display counter with 6 mm curved glass on 1 side. Polished stainless steel bar diameter 40 mm. Height 385 mm with 1 level and 655 mm with 2. 240 v single-phase power supply. Available as add-on: under-shelf single LED lighting strip or single/double lighting strip under double shelves. LED lighting. Vibrated and polished.

Display counters for built-in refrigerated elements - 1 level

Tank	Lighting wattage (per shelf)		Single shelf	
	LED		Item no.	Price in € (plus VAT)
2 GN1/1	8		PICS08	691
3 GN1/1	14		PICS12	711
4 GN1/1	20		PICS16	726
5 GN1/1	26		PICS20	1,038
6 GN1/1	30		PICS23	1,060

Single shelf + LED lighting	
Item no.	Price in € (plus VAT)
PICS08LED	1,078
PICS12LED	1,236
PICS16LED	1,451
PICS20LED	1,667
PICS23LED	1,667

Display counters for built-in refrigerated elements - 2 levels

Tank	Lighting wattage (per shelf)		Single shelf	
	LED		Item no.	Price in € (plus VAT)
2 GN1/1	8		PICD08	1,047
3 GN1/1	14		PICD12	1,164
4 GN1/1	20		PICD16	1,191
5 GN1/1	26		PICD20	1,551
6 GN1/1	30		PICD23	1,798

Double shelf + LED lighting 1 level	
Item no.	Price in € (plus VAT)
PICD08LED1	1,494
PICD12LED1	1,716
PICD16LED1	1,808
PICD20LED1	2,409
PICD23LED1	3,865

Single shelf + LED lighting 2 levels	
Item no.	Price in € (plus VAT)
PICD08LED2	1,792
PICD12LED2	1,859
PICD16LED2	2,049
PICD20LED2	2,529
PICD23LED2	2,787

DESCRIPTION

Display counter with 6 mm tempered curved glass on both sides. Polished stainless steel bars diameter 40 mm. Height 530 mm. 240 v single-phase power supply. Available as add-on: under-shelf LED lighting strip.

Display counters for built-in refrigerated elements - 1 level with tempered curved glass on both sides

Tank	Lighting wattage (per shelf)		Single shelf	
	LED		Item no.	Price in € (plus VAT)
2 GN1/1	8		PICC08	796
3 GN1/1	14		PICC12	959
4 GN1/1	20		PICC16	1,240
5 GN1/1	26		PICC20	1,369
6 GN1/1	30		PICC23	1,501

Single shelf + LED lighting	
Item no.	Price in € (plus VAT)
PICC08LED	1,205
PICC12LED	1,498
PICC16LED	1,900
PICC20LED	2,187
PICC23LED	2,375

COLD ADD-ONS

Enodis
BUILT-IN

COLD UNITS

REFRIGERATED DROP-IN WELL FOR STARTERS/DESSERTS AND DRINKS - ADD-ONS

Item no.	Name	Price in € (plus VAT)
BE4L	Condensate drip tray, capacity 4 litres for drop-in wells	471
SPLITSYSTEM	Additional charge for each remote refrigeration unit with Split System connection (per 3 m of tubing)	502

ADD-ONS FOR VENTILATED REFRIGERATED DROP-IN WELLS & "CRISTALINE"/"ÉLÉGANCE" DISPLAY CABINETS

Item no.	Name	Price in € (plus VAT)
BE14L	Condensate drip tray, capacity 14 litres for drop-in wells	544
SPLITSYSTEM	Additional charge for each remote refrigeration unit with Split System connection (per 3 m of tubing)	553

DISPLAY COUNTER ADD-ONS

Item no.	Name	Price in € (plus VAT)
PVHP530	Additional charge for display counter height 530 mm	171

Additional charge for control panel add-on - please ask us

03
HOT

Technical Information

- **All AISI 304 (18-10) stainless steel** construction .
- AISI 304 stainless steel **top thickness 2 mm vibrated and polished.**

Specifications

- **Ventilated air-heated tank with welded rounded corners** and self-adhesive 1.8 mm stainless steel armoured fin heaters on the underside of the tank with axial fans. Maximum tray depth 150 mm. Temperature range 65°C to 105°C
- **Ventilated air-heated tank with welded rounded corners** and diamond pattern toward 3/4" drain plug. With self-adhesive 1.8 mm stainless steel armoured fin heaters on the underside of the tank. Maximum tray depth 150 mm. Temperature range 65°C to 85°C.
Tank fill automatically stops when full. 2 water level detection probes (min. and max. levels).
- **Top heated by black tempered glass-ceramic panels**, thickness 6 mm GN1/1 (505 x 325 mm). Temperature range 65°C to 105°C.
- **Ventilated chamber** with rock wool insulation. Temperature range 0°C to 85°C. Sliding doors with rock wool insulation. Power 230 v single-phase or 400 v 3-phase, Neutral and Earth.
- **Display counters**
Loose or with heating or lighting
High quality ceramic heating ramp, power 150 W/lamp with variothermal insulation.

Complies with AFNOR standard AC D 40-004 (the French industrial standards authority).

HEATED GLASS-CERAMIC TOPS

Enodis
BUILT-IN

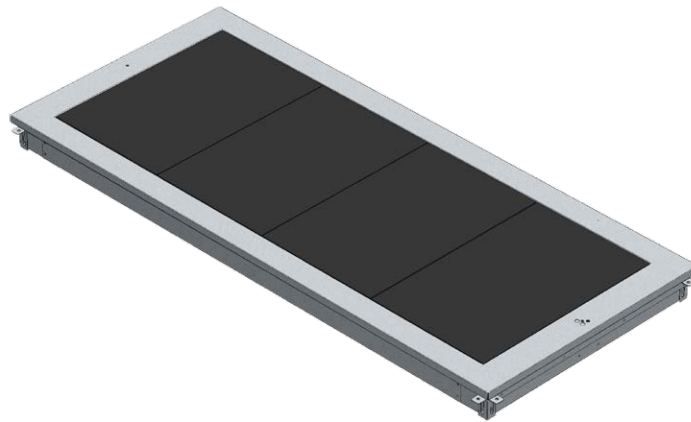

DESCRIPTION

AISI 304 stainless steel structure. Temperature-holding surface and 2 shelves made of GN1/1 black tempered glass panels thickness 6 mm heated underneath by adhesive elements. Power 240 v single-phase or 400 v 3-phase (depending on model). Ultra temperature uniformity at 90°C. Temperature display. Protection rating IP22. Vibrated and polished.

Heated glass-ceramic tops

Tray capacity	Power (w) Electric	Power supply	Dimensions W x D x H mm	Item no.	Price in € (plus VAT)
2 GN1/1	900	230/50/1 + N	810 x 640 x 60/80*	DIPV2	4,371
3 GN1/1	1,350	400/50/3+ N	1,135 x 640 x 60/80*	DIPV3	4,538
4 GN1/1	1800	400/50/3+ N	1,460 x 640 x 60/80*	DIPV4	4,773
5 GN1/1	2,250	400/50/3+ N	1,785 x 640 x 60/80*	DIPV5	4,860
6 GN1/1	2,700	400/50/3+ N	2,110 x 640 x 60/80*	DIPV6	5,287

*60 mm = built-in height - 80 mm = total height

WATER BAIN-MARIE AND FORCED-AIR BAIN-MARIE TANKS

Enodis
BUILT-IN

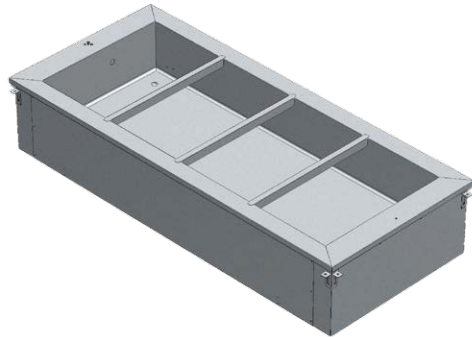

water bain-marie tank

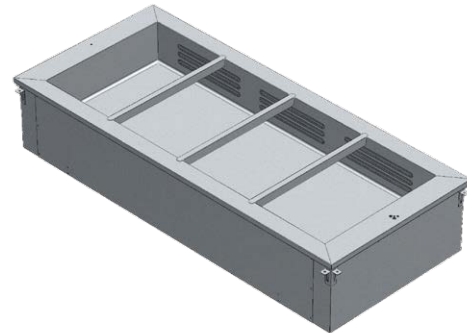

forced-air bain-marie tank

DESCRIPTION

AISI 304 stainless steel structure. Underside heating using adhesive elements. Auto fill via solenoid valve. Tank for GN1/1 trays depth 150 mm (not included) Drainage via plug. Temperature display. Protection rating IP22. Power 240 v single-phase or 400 v 3-phase (depending on model). Vibrated and polished.

Water bain-marie tanks

Tray capacity	Power (w) Electric	Power supply	Dimensions W x D x H mm	Item no.	Price in € (plus VAT)
2 GN1/1	1,500	230/50/1 + N	810 x 640 x 290/310*	DIBMH2	3,676
3 GN1/1	2,250	400/50/3+ N	1,135 x 640 x 290/310*	DIBMH3	3,847
4 GN1/1	3,000	400/50/3+ N	1,460 x 640 x 290/310*	DIBMH4	4,070
5 GN1/1	3,750	400/50/3+ N	1,785 x 640 x 290/310*	DIBMH5	4,516
6 GN1/1	4,500	400/50/3+ N	2,110 x 640 x 290/310*	DIBMH6	5,197

*290 mm = built-in height - 310 mm = total height

DESCRIPTION

Radiant ventilated tank heated by hot air circulation. Armoured heating elements and axial fan. Tank for GN1/1 trays depth 150 mm (not included) Temperature display. Protection rating IP22. Power 240 v single-phase or 400 v 3-phase (depending on model). Vibrated and polished.

Hot air bain-marie tanks

Tray capacity	Power (w) Electric	Power supply	Dimensions W x D x H mm	Item no.	Price in € (plus VAT)
2 GN1/1	1,550	230/50/1 + N	810 x 640 x 330/350*	DIBMV2	3,843
3 GN1/1	3,100	230/50/1 + N	1,135 x 640 x 330/350*	DIBMV3	4,025
4 GN1/1	4,650	400/50/3+ N	1,460 x 640 x 330/350*	DIBMV4	4,406
5 GN1/1	4,650	400/50/3+ N	1,785 x 640 x 330/350*	DIBMV5	4,669
6 GN1/1	6,200	400/50/3+ N	2,110 x 640 x 330/350*	DIBMV6	5,223

*330 mm = built-in height - 355 mm = total height

BAIN-MARIE & VITROCHO DISPLAY COUNTERS

Enodis
BUILT-IN

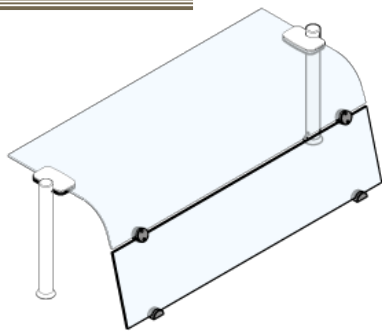

bain-marie display counter

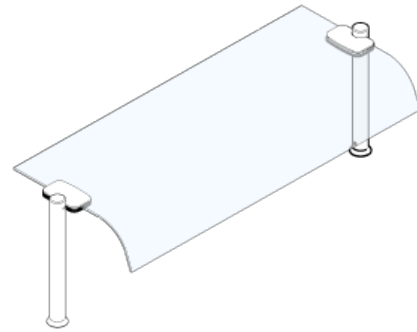

vitrocho display counter

DESCRIPTION

Bain-marie display counter with tempered curved glass 6 mm. Polished stainless steel bars diameter 40 mm. Height 385 mm. Vertical guard in white tempered glass 6 mm. Available as add-on: ceramic heating ramp + LED lighting under single shelf. LED lighting. 240 v single-phase power supply. Vibrated and polished.

Bain-marie display counters

Tank	Power (w) LED lighting + heating	Single shelf	
		Item no.	Price in € (plus VAT)
2 GN1/1	8 + 150	TDSB08	739
3 GN1/1	14 + 300	TDSB12	776
4 GN1/1	20 + 300	TDSB16	886
5 GN1/1	26 + 450	TDSB20	1,034
6 GN1/1	30 + 450	TDSB23	1,179

Single shelf + LED lighting + heating	
Item no.	Price in € (plus VAT)
TDSB08CLED	1,564
TDSB12CLED	1,638
TDSB16CLED	1,844
TDSB20CLED	2,318
TDSB23CLED	2,748

DESCRIPTION

Vitrocho display counter: single tempered curved glass shelf 6 mm. Polished stainless steel bar diameter 40 mm. Height 385 mm. Available as add-on: ceramic heating ramp + lighting under single shelf. LED lighting. 240 v single-phase power supply. Vibrated and polished.

Vitrocho surface display counters

Tank	Power (w) LED lighting + heating	Single shelf	
		Item no.	Price in € (plus VAT)
2 GN1/1	8 + 150	TDSV08	696
3 GN1/1	14 + 300	TDSV12	733
4 GN1/1	20 + 300	TDSV16	748
5 GN1/1	26 + 450	TDSV20	1,070
6 GN1/1	30 + 450	TDSV23	1,093

Single shelf + LED lighting + heating	
Item no.	Price in € (plus VAT)
TDSV08CLED	1,522
TDSV12CLED	1,612
TDSV16CLED	1,905
TDSV20CLED	2,243
TDSV23CLED	2,537

DISPLAY COUNTER ADD-ONS

Item no.	Name	Price in € (plus VAT)
PVHP530	Additional charge for display counter height 530 mm	171

BUILT-IN “CRISTALINE” HEATED OPEN DISPLAY CABINETS

Enodis
BUILT-IN

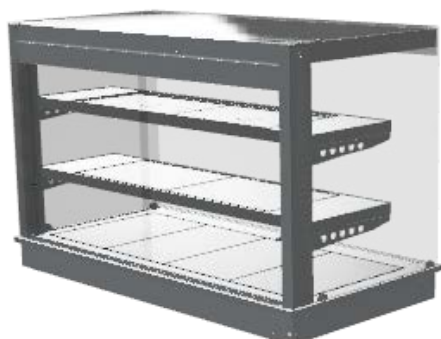

double shelf

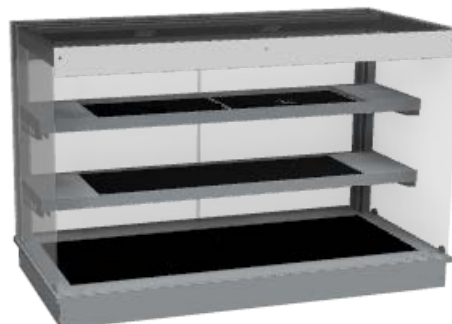

double shelf

DESCRIPTION

AISI 304 stainless steel structure. Rectangular heated display cabinet. Temperature-holding surface and 1, 2 or 3 shelves made of GN1/1 black tempered glass panels heated underneath by adhesive elements. Ultra temperature uniformity at 90°C. Open on customer side. 2 Plexiglass sliding doors on service side. LED lighting. Power 400 v 3-phase. Vibrated and polished.

Built-in “Cristaline” heated open display cabinets with 1 shelf

Tray capacity	Electrical power	Dimensions W x D x H mm	Item no.	Price in € (plus VAT)
2 GN1/1	900	810 x 740 x 100/725*	DIVCO1C2	10,017
3 GN1/1	1,350	1,135 x 740 x 100/725*	DIVCO1C3	10,760
4 GN1/1	1,800	1,460 x 740 x 100/725*	DIVCO1C4	11,902
5 GN1/1	2,250	1,785 x 740 x 100/725*	DIVCO1C5	13,116

*100 mm = built-in height - 725 mm = total height

Built-in “Cristaline” heated open display cabinets with 2 heated shelves

Tray capacity	Electrical power	Dimensions W x D x H mm	Item no.	Price in € (plus VAT)
2 GN1/1	900	810 x 740 x 100/925*	DIVCO2C2	12,294
3 GN1/1	1,350	1,135 x 740 x 100/925*	DIVCO2C3	13,523
4 GN1/1	1,800	1,460 x 740 x 100/925*	DIVCO2C4	15,081
5 GN1/1	2,250	1,785 x 740 x 100/925*	DIVCO2C5	16,687

*100 mm = built-in height - 925 mm = total height

Built-in “Cristaline” heated open display cabinets with 3 heated shelves

Tray capacity	Electrical power	Dimensions W x D x H mm	Item no.	Price in € (plus VAT)
2 GN1/1	900	810 x 740 x 1,088	DIVCO3C2	12,729
3 GN1/1	1,350	1,135 x 740 x 1,088	DIVCO3C3	15,125
4 GN1/1	1,800	1,460 x 740 x 1,088	DIVCO3C4	16,399
5 GN1/1	2,250	1,785 x 740 x 1,088	DIVCO3C5	18,149

*100 mm = built-in height - 925 mm = total height

BUILT-IN “CRISTALINE” HEATED CLOSED DISPLAY CABINETS WITH HEATED SURFACE

Enodis
BUILT-IN

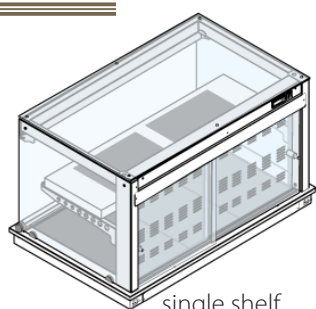

single shelf

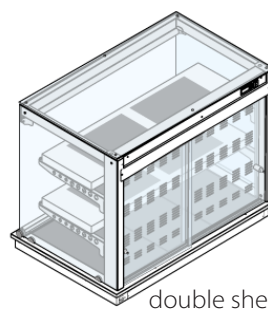

double shelf

DESCRIPTION

AlSi 304 stainless steel structure. Rectangular heated display cabinet. Temperature-holding surface and 1, 2 or 3 shelves made of GN1/1 black tempered glass panels heated underneath by adhesive elements. Ultra temperature uniformity at 90°C. Straight glass cover on hydraulic cylinders for easy lifting and cleaning available. 2 Plexiglass sliding doors on service side. LED lighting. Power 400 v 3-phase. Vibrated and polished.

Built-in “Cristaline” heated closed glass display units with glass cover and 1 heated shelf

Tray capacity	Electrical power	Dimensions W x D x H mm	Item no.	Price in € (plus VAT)
2 GN1/1	1,490	810 x 740 x 688	DIVCF1C2	13,385
3 GN1/1	2,350	1,135 x 740 x 688	DIVCF1C3	13,754
4 GN1/1	2,780	1,460 x 740 x 688	DIVCF1C4	14,182
5 GN1/1	3,740	1,785 x 740 x 688	DIVCF1C5	15,157

Built-in “Cristaline” heated closed glass display units with glass cover and 2 heated shelves

Tray capacity	Electrical power	Dimensions W x D x H mm	Item no.	Price in € (plus VAT)
2 GN1/1	2,020	810 x 740 x 888	DIVCF2C2	15,661
3 GN1/1	3,310	1,135 x 740 x 888	DIVCF2C3	16,517
4 GN1/1	3,740	1,460 x 740 x 888	DIVCF2C4	17,362
5 GN1/1	5,180	1,785 x 740 x 888	DIVCF2C5	18,726

Built-in “Cristaline” heated closed glass display units with glass cover and 3 heated shelves

Tray capacity	Electrical power	Dimensions W x D x H mm	Item no.	Price in € (plus VAT)
2 GN1/1	2,550	810 x 740 x 1,088	DIVCF3C2	16,097
3 GN1/1	4,270	1,135 x 740 x 1,088	DIVCF3C3	18,121
4 GN1/1	4,700	1,460 x 740 x 1,088	DIVCF3C4	18,682
5 GN1/1	6,610	1,785 x 740 x 1,088	DIVCF3C5	20,190

BUILT-IN “ÉLÉGANCE” HEATED OPEN DISPLAY CABINETS

Enodis
BUILT-IN



DESCRIPTION

AISI 304 stainless steel structure. Rounded heated display cabinet. Temperature-holding surface and 1, 2 or 3 shelves made of GN1/1 black tempered glass panels heated underneath by adhesive elements. Ultra temperature uniformity at 90°C.

Open on customer side. 2 Plexiglass sliding doors on service side. LED lighting.

Power 400 v 3-phase. Vibrated and polished.

Built-in “Élégance” heated open display cabinets with 1 heated shelf

Tray capacity	Electrical power	Dimensions W x D x H mm	Item no.	Price in € (plus VAT)
2 GN1/1	1,490	810 x 740 x 680	DIVCO1A2	9,726
3 GN1/1	2,350	1,135 x 740 x 680	DIVCO1A3	10,446
4 GN1/1	2,780	1,460 x 740 x 680	DIVCO1A4	11,555
5 GN1/1	3,740	1,785 x 740 x 680	DIVCO1A5	12,735

Built-in “Élégance” heated open display cabinets with 2 heated shelf

Tray capacity	Electrical power	Dimensions W x D x H mm	Item no.	Price in € (plus VAT)
2 GN1/1	2,020	810 x 740 x 872	DIVCO2A2	12,294
3 GN1/1	3,310	1,135 x 740 x 872	DIVCO2A3	13,523
4 GN1/1	3,740	1,460 x 740 x 872	DIVCO2A4	15,081
5 GN1/1	5,180	1,785 x 740 x 872	DIVCO2A5	16,687

SELF-SERVICE TAKEAWAY



Enodis
SELF-SERVICE TAKEAWAY



**SELF-SERVICE
TAKEAWAY**

01
DISPLAY
CABINETS **228**

02
LOOSE
UNITS **236**

03

CASH DESKS

.....242

04

CORNER UNITS

248.....

01 DISPLAY CABINETS

Choisissez votre **boisson** et/ou **dessert**





VBI15N
(cabinet in black)

Enodis

SELF-SERVICE
TAKEAWAY

Our most POPULAR PRODUCTS

Vertical floor standing display cabinet

- Vertical refrigerated display cabinet with rear ventilation.
- Perforated stainless steel double floor. HCFO foam insulation thickness 30 mm.
- 4 fully adjustable shelves (no tools needed).
- Semi-rigid night curtain with standard lock and key.
- LED lighting.
- 2 laminate side panels to select from our range.
- 2 laminate side panels to select from our range.
- Electronic controls.
- Integrated drip tray.
- HCFO foam insulation, density 42 kg/m³.
- Refrigeration system noise level 56dB(A). Uses freon R455A, power supply single-phase 230 volts. Comes with removable frame.



Cold glass display units.

- Ventilated refrigerated display cabinet cabinets. Customer side with closable 45° glass cover on hydraulic cylinders for easy lifting and cleaning.
- HCFO foam insulation, density 42 kg/m³.
- 2 Plexiglass sliding doors on service side (removable without tools). 1 or 2 detachable glass shelves.
- LED lighting.
- Operating temperature: 4°C/8°C in tank.
- Noise level with refrigeration unit 56 dB(A). Comes with removable frame.
- Refrigeration system noise level 56dB(A). Uses refrigerant R455A, power supply single-phase 230 volts. Comes with removable frame.
- Electronic controls.
- Integrated drip tray.

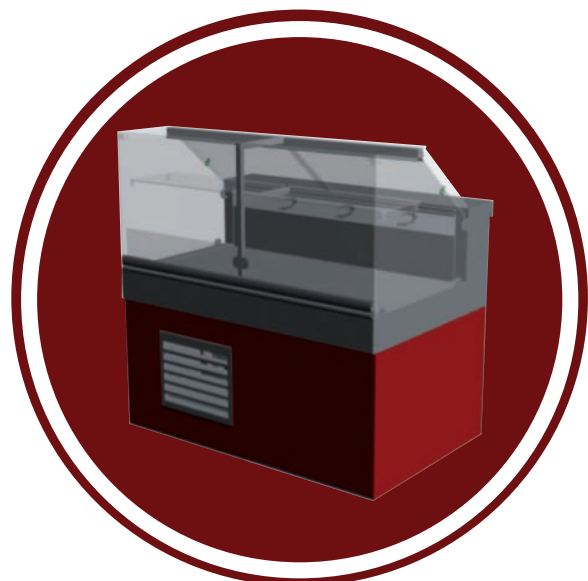

VERTICAL DISPLAY CABINETS

Enodis
SELF-SERVICE TAKEAWAY



DESCRIPTION

AISI 304 stainless steel structure. Vertical refrigerated display cabinet with rear ventilation. Perforated stainless steel double floor. HCFO foam insulation. Condensate drip tray included. 4 fully adjustable shelves (no tools needed). Refrigeration unit uses refrigerant R455A. Semi-rigid night curtain with lock and key. LED lighting. Electronic control. 2 laminate side panels to select from our range. Operating temperature 4°C/8°C. Display cabinet without refrigeration unit does not include drip tray. Available in all stainless steel or laminate trim (please select your colour from our colour chart).

Vertical refrigerated display cabinets

Item no.	Dimension W x D x H	Power supply	Power		With refrigeration unit	Without refrigeration unit	Add-on glass swing doors**
			Power (w)	Cooling capacity (-10°)	Price in € (plus VAT)	Price in € (plus VAT)	
VBI10	1,000 x 700 x 2,044	240/50/1 + N	900	1,166	11,580	10,191	1,667
VBI15	1,500 x 700 x 2,044	240/50/1 + N	1,200	1,573	14,551	12,805	2,085
VBI18	1,800 x 700 x 2,044	240/50/1 + N	1,400	1,717	17,329	15,250	2,668

*Add R to item number for display cabinet without refrigeration unit

**Add PV to item number for add-on swing doors (display cabinet)

Vertical refrigerated display cabinet in black (interior & exterior)

Item no.	Dimension W x D x H	Power supply	Power		With refrigeration unit	Without refrigeration unit	Add-on glass swing doors**
			Power (w)	Cooling capacity (-10°)	Price in € (plus VAT)	Price in € (plus VAT)	
VBI10N	1,000 x 700 x 2,044	240/50/1 + N	900	1,166	12,366	12,350	1,667
VBI15N	1,500 x 700 x 2,044	240/50/1 + N	1,200	1,573	15,363	15,355	2,085
VBI18N	1,800 x 700 x 2,044	240/50/1 + N	1,400	1,717	18,372	18,515	2,668

*Add R to item number for display cabinet without refrigeration unit

**Add PV to item number for add-on swing doors (display cabinet)

Example: item number for 1,500 mm refrigerated display cabinet entirely in black with swing doors - Ref. VBI15NP

REFRIGERATED SANDWICH DISPLAY CABINETS ON OPEN CUPBOARD - STRAIGHT GLASS

Enodis

SELF-SERVICE TAKEAWAY



DESCRIPTION

AISI 304 stainless steel. AISI 304 stainless steel top thickness 2 mm. Laminate façade with 15 mm elevation. Ventilated refrigerated drop-in well with detachable bottom. Evaporator guard removes easily. Noise level with refrigeration unit 56 dB(A). Comes with removable frame. Refrigerant R455A. HCFO foam insulation. Electronic control. Rounded refrigerated display cabinet with rear ventilation. Customer side with closable 25° glass cover on hydraulic cylinders for easy lifting and cleaning. 2 Plexiglass sliding doors (removable without tools). 1 or 2 detachable glass shelves. LED lighting. Operating temperature: 4°C/8°C in tank. Condensate drip tray system included. Power supply: single-phase 240 v 50 Hz. Available without refrigeration unit (comes with vacuum pump, control facility, pressure regulator and evaporator). Unit without refrigeration unit does not include drip tray.

Cold display cabinets with straight glass - 1 shelf

Item no.	Dimension W x D x H	Operating temp.	Power		With refrigeration unit	Without refrigeration unit
			Power (w)	Cooling capacity (w)	Price in € (plus VAT)	Price in € (plus VAT)
VSF1D1200	1,200 x 815 x 900/1,145	+4°C / +8°C	700	724 W at -10°C	13,415	12,575
VSF1D1600	1,600 x 815 x 900/1,145	+4°C / +8°C	820	972 W at -10°C	14,755	13,915
VSF1D2000	2,000 x 815 x 900/1,145	+4°C / +8°C	800	1,166 W at -10°C	17,115	16,275

Cold display cabinets with straight glass - 2 shelves

Item no.	Dimension W x D x H	Operating temp.	Power		With refrigeration unit	Without refrigeration unit
			Power (w)	Cooling capacity (w)	Price in € (plus VAT)	Price in € (plus VAT)
VSF2D1200	1,200 x 815 x 900/1,145	+4°C / +8°C	700	724 W at -10°C	14,133	13,293
VSF2D1600	1,600 x 815 x 900/1,145	+4°C / +8°C	820	972 W at -10°C	15,041	14,201
VSF2D2000	2,000 x 815 x 900/1,145	+4°C / +8°C	900	1,166 W at -10°C	17,468	16,628

VITRO HEATED SANDWICH DISPLAY CABINETS WITH STRAIGHT GLASS ON OPEN CUPBOARD

Enodis

SELF-SERVICE TAKEAWAY



DESCRIPTION

AISI 304 stainless steel. Stainless steel top thickness 2 mm. Laminate façade with 15 mm elevation. Ventilated heated tank with detachable bottom. Electronic control. Rectangular heated glass-ceramic display cabinet. Temperature-holding surface and 2 shelves made of GN1/1 black tempered glass panels thickness 6 mm heated underneath by adhesive elements. Ultra temperature uniformity at 90°C. Customer side has closable 25° glass cover on hydraulic cylinders for easy lifting and cleaning. 2 Plexiglass sliding doors (removable without tools). 1 or 2 detachable glass shelves. LED lighting. Operating temperature 65 to 90°C. Power supply: single-phase 240 v 50 Hz.

Vitro static heated display cabinets with straight glass - 1 shelf

Item no.	Dimension W x D x H	Operating temp.	Power Power (w)	Price in € (plus VAT)
VSV1D1200	1,200 x 815 x 900/1,145	+65 to 90°C	1,370	12,032
VSV1D1600	1,600 x 815 x 900/1,145	+65 to 90°C	1,825	13,449
VSV1D2000	2,000 x 815 x 900/1,145	+65 to 90°C	2,280	15,899

Vitro static heated display cabinets with straight glass - 2 shelves

Item no.	Dimension W x D x H	Operating temp.	Power Power (w)	Price in € (plus VAT)
VSV2D1200	1,200 x 815 x 900/1,145	+65 to 90°C	1,370	12,319
VSV2D1600	1,600 x 815 x 900/1,145	+65 to 90°C	1,825	13,734
VSV2D2000	2,000 x 815 x 900/1,145	+65 to 90°C	2,280	16,252

VENTILATED HEATED SANDWICH DISPLAY CABINETS WITH STRAIGHT GLASS ON OPEN CUPBOARD

Enodis

SELF-SERVICE TAKEAWAY

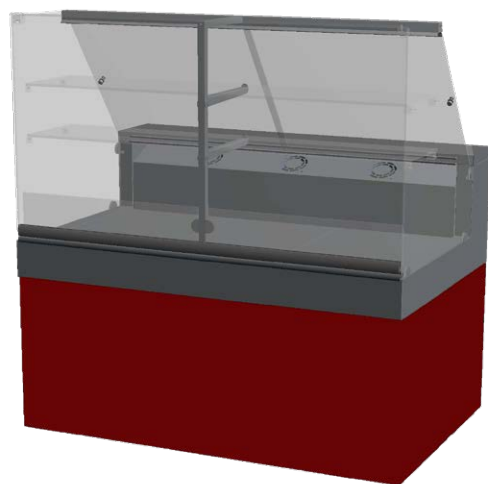

DESCRIPTION

AISI 304 stainless steel. Stainless steel top thickness 2 mm. Laminate façade with 15 mm elevation. Ventilated heated tank with detachable bottom. Electronic control. Rectangular heated glass-ceramic display cabinet. Customer side with closable 25° glass cover on hydraulic cylinders for easy lifting and cleaning. 2 Plexiglass sliding doors (removable without tools). 1 or 2 detachable glass shelves. LED lighting. Operating temperature +45 to 60°C. Power supply: single-phase 240 v 50 Hz.

Heated display cabinets with straight glass - 1 shelf

Item no.	Dimension W x D x H	Operating temp.	Power Power (w)	Price in € (plus VAT)
VSC1D1200	1,200 x 815 x 900/1,145	45 to 60°C	2,000	11,592
VSC1D1600	1,600 x 815 x 900/1,145	45 to 60°C	2,100	12,777
VSC1D2000	2,000 x 815 x 900/1,145	45 to 60°C	2,400	15,077

Ventilated heated display cabinets with straight glass - 2 shelves

Item no.	Dimension W x D x H	Operating temp.	Power Power (w)	Price in € (plus VAT)
VSC2D1200	1,200 x 815 x 900/1,145	45 to 60°C	2,000	12,116
VSC2D1600	1,600 x 815 x 900/1,145	45 to 60°C	2,100	13,064
VSC2D2000	2,000 x 815 x 900/1,145	45 to 60°C	2,400	15,475

02

LOOSE UNITS

Technical Information

- All AISI 304 (18-10) stainless steel structure.
- AISI 304 stainless steel top thickness 2 mm with grain satin polish. Customer side counter surface profile rounded edge with 110 mm drop.
- Customer side façade in laminate water-repellent melamine. The façade has a 15 mm elevation as standard. Includes lower stainless corner guard.
- Panels are fitted with an interlocking clip system and held in place by brackets.
- Service side fascia panel attached with easily removable screws for access.
- Complies with AFNOR standard AC D 40-004 (the French industrial standards authority).



Enodis

SELF-SERVICE
TAKEAWAY

Our most POPULAR PRODUCTS

Loose units

- Storage unit on open cupboard or open with adjustable floor and shelf, or with sliding doors (note: 800 mm unit comes with swing door).
- External corner unit with laminate façade and rail on customer side.
- Internal corner unit open with floor and adjustable shelf on service side.
- Cash desk with lockable stainless steel drawer with key, top surface cable duct and single-phase 220 V socket.

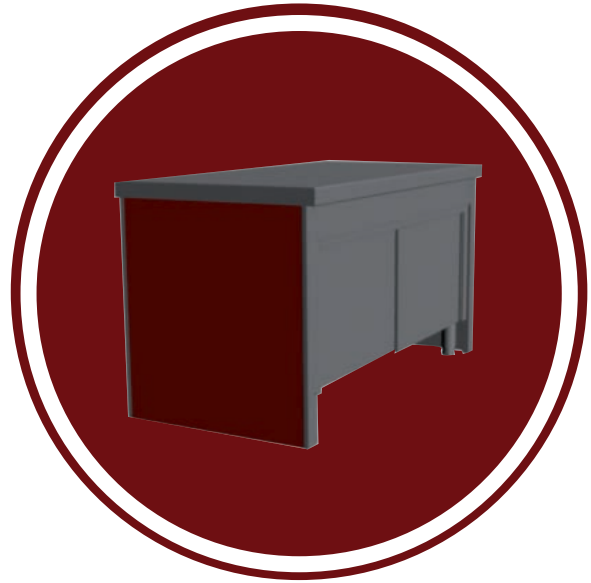

LOOSE UNITS ON OPEN CUPBOARD WITH OPEN & CLOSED STORAGE

Enodis
SELF-SERVICE TAKEAWAY



DESCRIPTION

AISI 304 stainless steel. Stainless steel top thickness 2 mm. Laminate façade with 15 mm elevation. Storage units with adjustable floor and shelf. Closed unit with sliding doors.

Loose units

Dimension W x D x H	Unit on open cupboard Stainless steel top	
	Item no.	Price in € (plus VAT)
800 x 830 x 900	MNBL08ES-VAE	2,002
1,200 x 830 x 900	MNBL12ES-VAE	2,315
1,600 x 830 x 900	MNBL16ES-VAE	2,670
2,000 x 830 x 900	MNBL20ES-VAE	3,045
2,300 x 830 x 900	MNBL23ES-VAE	3,398

Unit with open storage Stainless steel top	
Item no.	Price in € (plus VAT)
MNO08ES-VAE	2,511
MNO12ES-VAE	2,904
MNO16ES-VAE	3,362
MNO20ES-VAE	3,874
MNO23ES-VAE	4,476

Unit with closed storage Stainless steel top	
Item no.	Price in € (plus VAT)
MNF08ES-VAE	3,040
MNF12ES-VAE	3,371
MNF16ES-VAE	3,943
MNF20ES-VAE	4,631
MNF23ES-VAE	5,102



LOOSE UNITS

03

CASH DESKS

Technical Information

- All AISI 304 (18-10) stainless steel structure.
- AISI 304 stainless steel top thickness 2 mm with grain satin polish. Customer side counter surface profile rounded edge with 110 mm drop.
- Customer side façade in laminate water-repellent melamine. The façade has a 15 mm elevation as standard. Includes lower stainless corner guard.
- Panels are fitted with an interlocking clip system and held in place by brackets.
- Service side fascia panel attached with easily removable screws for access.
- Complies with AFNOR standard AC D 40-004 (the French industrial standards authority).



Enodis

SELF-SERVICE
TAKEAWAY

Our most POPULAR PRODUCTS

Cash desks

- Customer side with closable 45° glass cover on hydraulic cylinders for easy lifting and cleaning.
- Heated by hot air circulating from stainless steel heating elements and axial fan.
- Temperature control 65°C to 85°C.
- 2 Plexiglass sliding doors on service side (removable without tools). 1 or 2 detachable glass shelves.
- LED lighting.
- Electronic controls.

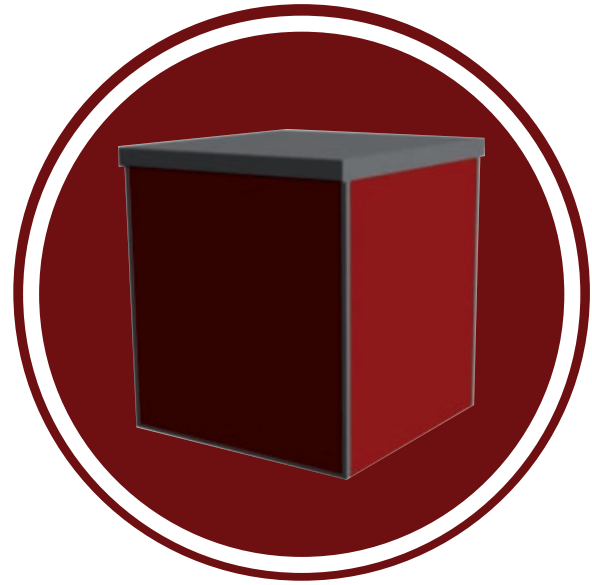

CASH DESKS

FRONTAL CASH DESKS

Enodis
SELF-SERVICE TAKEAWAY

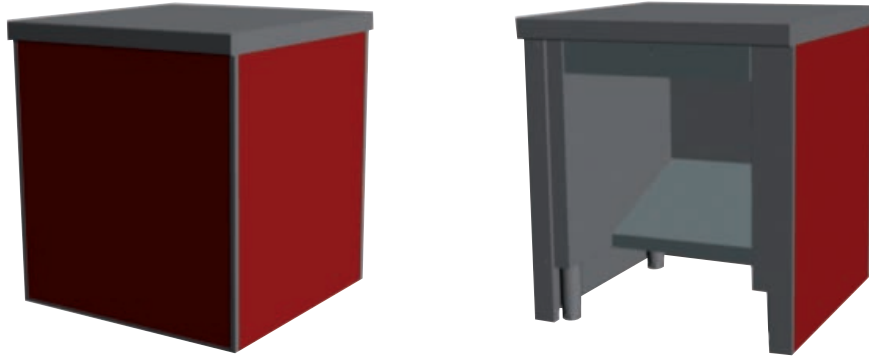

DESCRIPTION

AISI 304 stainless steel. Stainless steel top thickness 2 mm. Laminate façade with 15 mm elevation. Foot rest. Lockable stainless steel drawer with key. Cable entry aperture on top surface top.

Cash desk

Item no.	Dimensions W x D x H mm	Description	Price in € (plus VAT) Stainless steel top
CA80FES-VAE	800 x 830 x 900	Customer-facing unit	3,047

DESCRIPTION

AISI 304 stainless steel. Stainless steel top thickness 2 mm. Laminate façade with 15 mm elevation.

Wheelchair-accessible unit

Item no.	Dimensions W x D x H mm	Description	Price in € (plus VAT) Stainless steel top
MNBL08ESPMR-VAE	800 x 830 x 800	Open unit with wheelchair access	4,270



CASH DESKS

04

CORNER UNITS

Technical Information

- All AISI 304 (18-10) stainless steel structure.
- AISI 304 stainless steel top thickness 2 mm with grain satin polish. Customer side counter surface profile rounded edge with 110 mm drop.
- Customer side façade in laminate water-repellent melamine. The façade has a 15 mm elevation as standard. Includes lower stainless corner guard.
- Panels are fitted with an interlocking clip system and held in place by brackets.
- Service side fascia panel attached with easily removable screws for access.
- Complies with AFNOR standard AC D 40-004 (the French industrial standards authority).

EXTERNAL CORNER UNITS

Enodis
SELF-SERVICE TAKEAWAY

ROUNDED EXTERNAL CORNER UNITS

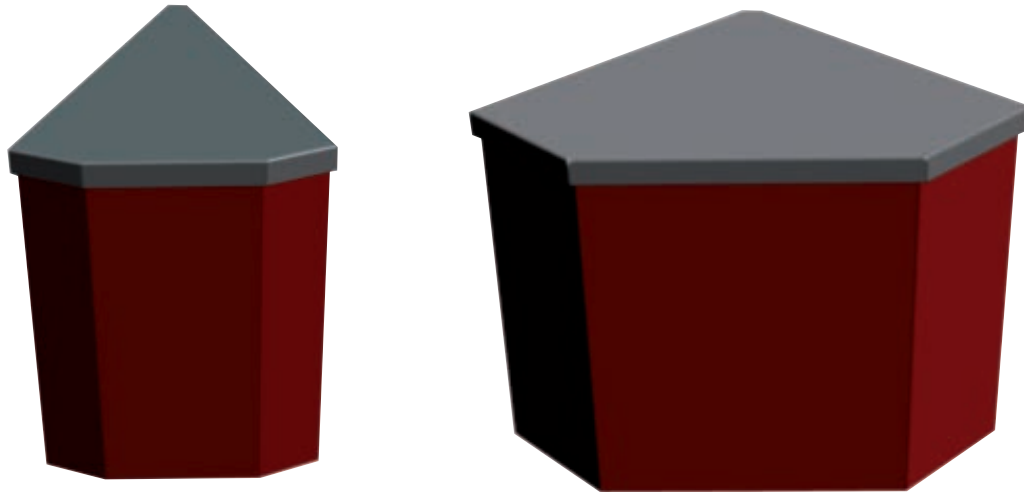

DESCRIPTION

AISI 304 stainless steel. Stainless steel top thickness 2 mm. Laminate façade with 15 mm elevation.
Height: 900 mm

External corner units

Item no.	Description	Price in € (plus VAT)
MAE90ES-VAE	90° corner (laminated façade on customer side)	2,216
MAE45ES-VAE	45° corner (laminated façade on customer side)	1,690
MAEC90ES-VAE	90° rounded corner (laminated façade on customer side)	4,913
MAEC45ES-VAE	45° rounded corner (laminated façade on customer side)	3,109

INTERNAL CORNER UNITS

Enodis
SELF-SERVICE TAKEAWAY

ROUNDED INTERNAL CORNER UNITS



DESCRIPTION

AISI 304 stainless steel. Stainless steel top thickness 2 mm. Laminate façade with 15 mm elevation.
Height: 900 mm

Internal corner units

Item no.	Description	Price in € (plus VAT)
MAI90ES-VAE	90° corner (open on customer side)	2,216
MAI45ES-VAE	45° corner (open on customer side)	1,690
MAIC90ES-VAE	90° corner (open on customer side)	5,221
MAIC45ES-VAE	45° corner (open on customer side)	3,419

HOTEL BUFFETS





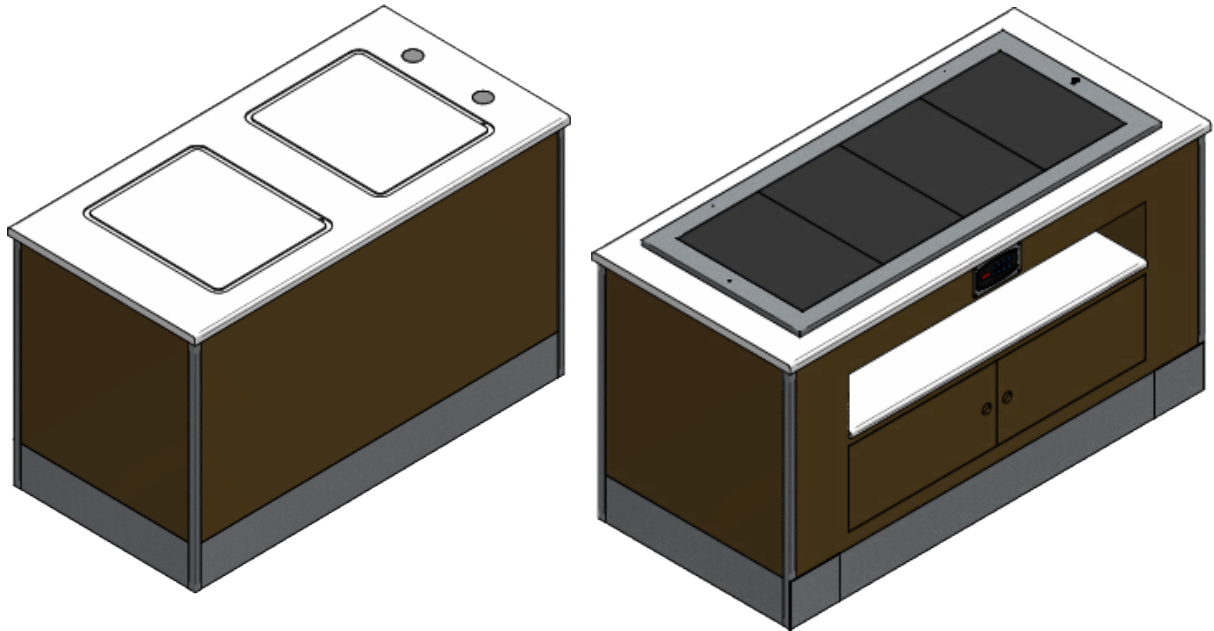

DESCRIPTION

AISI 304 stainless steel structure with joinery.
Reconstituted stone or granite counter surface (other coatings available).
Equipment available (list not exhaustive):

- Refrigerated zone with condensate drain.
- Reversible GN1/1 combi plate: -10°C to 85°C. Switchable from hot to cold and back by a simple press of the control. Available in black or off white. Flush installation with condensate drain.
- Temperature-hold zone.
- Plate recess.
- Storage cupboard underneath.
- Cable and plug duct.
- Mobile unit with access to wheels via flap.

Noise level with refrigeration unit 56 dB(A). Comes with removable frame. Refrigerant R455A.
HCFO foam insulation. Electronic control.
Operating temperature: 0°C/4°C.
Condensate drip tray system included.
Power supply: single-phase 240 v 50 Hz.

***Please ask us about our bespoke buffet designs.
(+33) 1 69 02 25 25 - contact@enodis.fr - www.enodis.fr***



HOTEL BUFFETS

Enodis
HOTEL BUFFETS

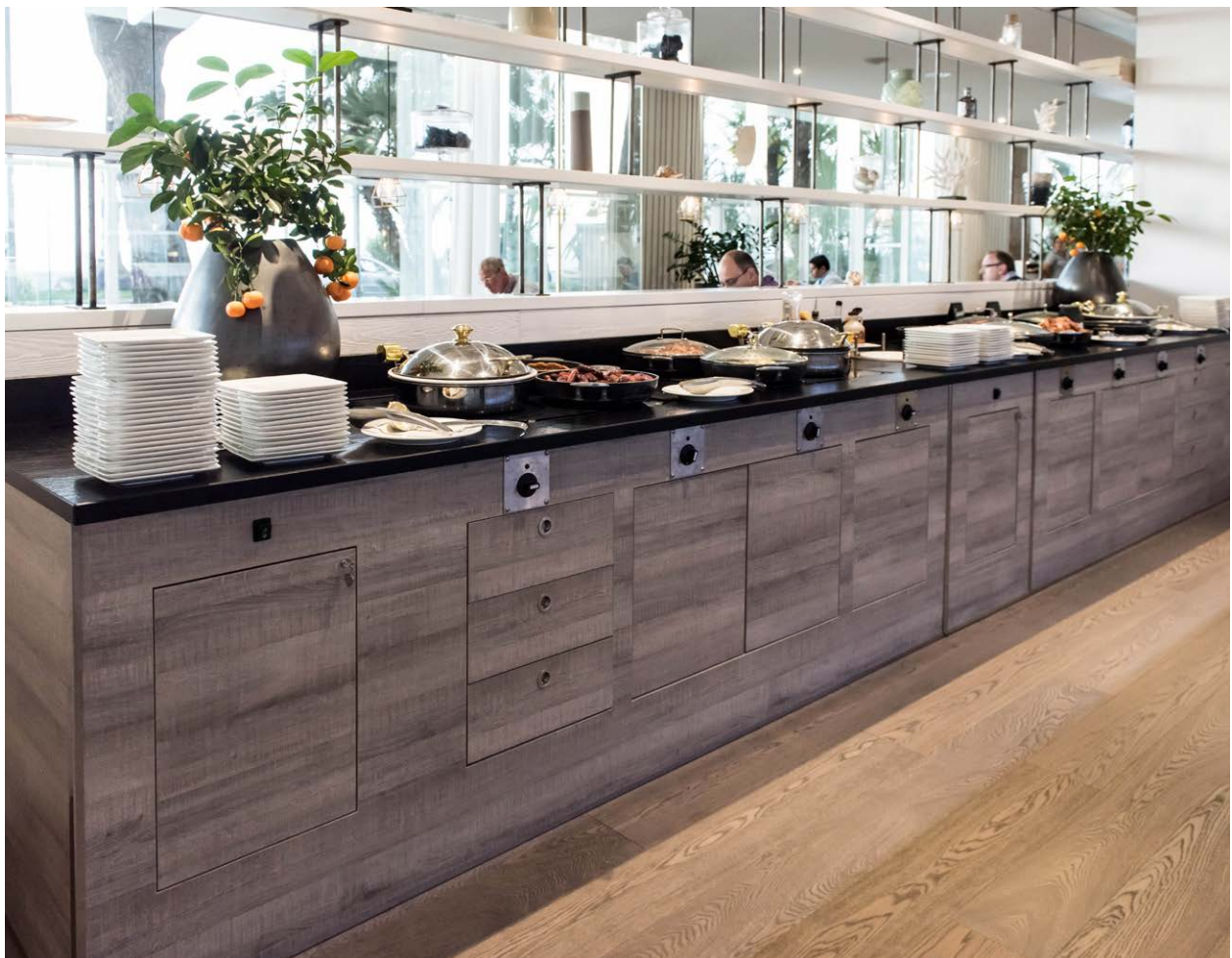

HOTEL BUFFETS

Enodis
HOTEL BUFFETS



HOTEL
BUFFETS

COLOUR CHART





01
PLAIN
COLOURS.....262

02
LEGNI DARK
WOOD EFFECT.....266

03
LEGNI LIGHT
WOOD EFFECT.....268



Micro-ondas
Fritadeira & Estufa



COLOUR CHART

LAMINATE FAÇADES

PLAIN COLOURS

Enodis
COLOURS

					
405 Bianco Porcellana	410 Bianco Ghiaccio	406 Bianco Primavera	411 Bianco	810 Mini Bianco	1813 Magnolia
					
418 Panna Crema	409 Latte	813 Beige Manhattan	414 Sabbia	415 Beige Chenise	416 Beige
					
413 Beige Ardenne	812 Rosa Viola	420 Beige Pastello	868 Grigio Medio	869 Grigio Alpaca	1833 Constantinople
					
1816 Sahara Beige	1945 Gange	1810 Grigio Autunno	867 Grigio Cielo	1831 Grigio Fango	854 Silver Bleue
					
478 Grigio Chiaro	479 Grigio Tortora	1819 Grigio Monviso	475 Grigio Perla	1809 Azzuro Koala	477 Grigio
					
480 Grigio Plomo	870 Grigio Lastra	871 Grigio Scuro	472 Grigio Londra	1946 Orage	879 Grigio Grafite

Please specify your colour choice when placing your order.
If you require a specific colour, please ask us for a quote.

COLOUR CHART

LAMINATE FAÇADES

PLAIN COLOURS

Enodis
COLOURS

					
1830 Grigio Etna	1820 Grigio Cosmico	454 Verde Caraibi	846 Turchese	486 Azzurro Lago	445 Verde Chiaro
					
1854 Verde Smeraldo	845 Verde Versailles	440 Verde Biliardo	450 Verde Lauro	460 Verde Erbetta	451 Sempreverde
					
1823 Verde Maquis	441 Verde Cedro	1850 Lime	842 Verde Sub	446 Verde Pastello	1851 Verde Mela
					
1855 Verde Pistacchio	1852 Verde Oliva	1853 Muschio	1947 Agave	1826 Cappuccino	892 West Brown
					
894 Viola Fumo	1828 Fondente	837 Samiento	893 Terra d'Ombra	424 Viola Tramonto	832 Rosso Lord
					
898 Bruno Fiandra	1870 Chocolat	1801 Giallo Ocra	412 Avorio	463 Giallo Pom-Pom	1940 India

**Please specify your colour choice when placing your order.
If you require a specific colour, please ask us for a quote.**

COLOUR CHART

LAMINATE FAÇADES

PLAIN COLOURS

Enodis
COLOURS

					
469 Giallo Africa	860 Giallo Piper	468 Giallo Canarie	862 Giallo Savana	1812 Giallo Polenta	861 Giallo Pop
					
835 Arancio Canyon	834 Rosso Woom	823 Rosso Tango	1822 Rosso Cavallino	431 Rosso	432 Terra Ocra
					
891 Scotch Brown	831 Rosso Mattone	435 Rosso Antico	836 Rosso Prugna	1880 Cipria	1882 Lilla Chiaro
					
828 Rosa Baby	830 Rosa Crazy Horse	1825 Rosa Patrimonio	494 Bougainville	427 Porpora	1841 Lampone
					
1881 Orchidea	1840 Fucsia	1821 Viola Sacro	1883 Melanzana	425 Lilla Erica	1827 Viola Campanula
					
423 Viola Madras	498 Viola Giglio	487 Azzuro Polvere	857 Celeste Myosotis	853 Bleu Spazio	858 Azzuro Pervinca

Please specify your colour choice when placing your order.
If you require a specific colour, please ask us for a quote.

COLOUR CHART

LAMINATE FAÇADES

PLAIN COLOURS

Enodis
COLOURS

PLAIN COLOURS

					
482 Bleu Panarea	1824 Blu Amorgos	437 Blue Giungla	499 Bleu California	1860 Samoa	801 Azzuro Tempesta
					
847 Azzurro	484 Blu Zaffiro	1818 Blu Intenso	430 Lilla Gemini	1834 Circé	850 Bleu Rada
					
838 Bleu Primario	851 Blu Cobalto	859 Blu Faenza	1804 Blu Tenebre	849 Blu Pavone	428 Blu Elettrico
					
496 Bleu Esperia	1942 Tuareg	1941 Cadaques	856 Blu Acciaio	1832 Grigio Tempesta	1861 Blu Notte
					
1944 Squalo	1943 Tenebre	897 Bruno Vulcano	852 Big Bleu	421 Nero	

**Please specify your colour choice when placing your order.
If you require a specific colour, please ask us for a quote.**

COLOUR CHART

LAMINATE FAÇADES

Enodis
COLOURS

"LEGNI DARK" WOOD EFFECT



1321
Rovere Stiria



1643
Ciliegio Rosa



1609
Ciliegio Pavese



1373
Mogano Virginia



1329
Noce Bossea



1328
Noce Rigato



1365
Noce Top



358
Noce Crea



1354
Zebrano Gold



648
Santos Scuro



391
Douglas Cocoa



392
Douglas Tobacco



1953
Montale Triora



601
Rovere Impero



656
Rovere Tennessee



657
Rovere America



604
Colony



605
Colony Brown

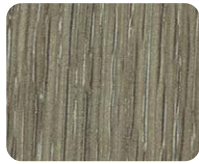

678
Quercia Nordica



1959
Fenice Amon



606
Artic Pine



1388
Zebrano Grigio



609
Amazzonia Sucupira



1382
Transversal Tobacco



616
Noce Sabec



677
Old Wood



603
Cedro Del Libano



674
Eucalipto



669
Rovere Primitivo



1395
Olmo Ambrato



1391
Olmo Grenoble



626
Noce Mondolè



664
Marbella

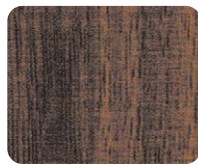

1389
Noce Iseo



634
Limba Noir



1387
Smoked Wood

*Please specify your colour choice when placing your order.
If you require a specific colour, please ask us for a quote.*

COLOUR CHART

LAMINATE FAÇADES

Enodis
COLOURS

"LEGNI DARK" WOOD EFFECT



1951
Hidalgo León



1355
Oak



658
Oak Nature



1965
Hidalgo Asturie



640
Larice



630
Noce Ellero



1393
Rovere Saraceno



1392
Rovere Moka



1318
Zebrano Moro



312
Wengè Zambia



313
Wengè Congo



330
Wengè Bangui

"LEGNI DARK" WOOD EFFECT

*Please specify your colour choice when placing your order.
If you require a specific colour, please ask us for a quote.*

COLOUR CHART

LAMINATE FAÇADES

Enodis
COLOURS

"LEGNI LIGHT" WOOD EFFECT



670
Rovere Artico



679
Pino Varaita



1383
Thunder Oak



675
Olmo Nelson



1385
White Ash



619
Grey Maple



1394
Olmo Perlato



607
Morgan Ash



1955
Montale Noli



672
Quercia Grigia



631
Teak Plissé



649
Santos Chiaro



1381
Transversal Oak



1386
Saw Cut Ash



1619
Rovere Trasversale



1379
Rovere Sud



1968
Betulla Nordica



1960
Fenice Iside



1958
Fenice Horus



1957
Fenice Aker

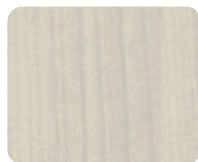

1678
Acero Ivory



1677
Acero Boston



385
Acero Ottawa



384
Rovere Toscano



1952
Montale Apricale



673
Quercia Miele



1396
Olmo Biondo



608
Grey Ash

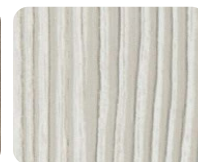

659
Pino Svizzera



660
Pino Savoia



661
Pino Chambery

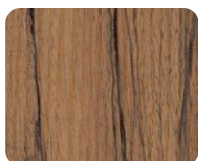

633
Limba Gold



620
Maple



1384
Frassino Maggiore

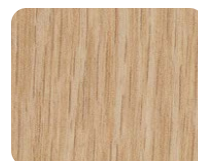

602
Rovere Boemia

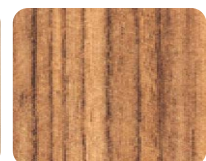

662
Teak Daniela

Please specify your colour choice when placing your order.

If you require a specific colour, please ask us for a quote.

COLOUR CHART

LAMINATE FAÇADES

Enodis
COLOURS

"LEGNI LIGHT" WOOD EFFECT



1954
Montale Verezzi

1956
Montale Cervo

386
Rovere Nazionale

668
Apple Tree

1666
Faggio Americano

1367
Faggio Veneto



1637
Pero Marine

1306
Radica Olmo

1948
Aurora Argentina

1962
Aurora Svezia

1963
Hidalgo Almería

1964
Hidalgo Aragona



388
Douglas Ice

381
Douglas Vanilla

370
Olmo Fine

387
Douglas

1611
Ciliegio Fey

639
Olmo Montano



680
Pino Susa

671
Faggio Rustico

1949
Aurora Islanda

650
Rovere Texas

1661
Rovere Montano

1324
Eastern Pecan



1961
Aurora Norvegia

321
Teak Asia

1621
Teak Maldive

1612
Teak Sumatra

"LEGNI LIGHT" WOOD EFFECT

**Please specify your colour choice when placing your order.
If you require a specific colour, please ask us for a quote.**

